



## WHEELCHAIR ACCESSIBLE VEHICLES



Mercedes-Benz

Citan

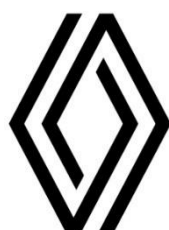

Kangoo



Townstar



## SPACIOUS, FLEXIBLE AND VERSATILE

A reliable family car with a wide range of seating options and optimal space and visibility for wheelchair passenger.

# Conversion manual

<b>Table of contents</b>		
1	<a href="#">Disassembly</a>	3
2	<a href="#">Exhaust disassembly</a>	9
3	<a href="#">Fuel system disassembly</a>	11
4	<a href="#">Marking the floor</a>	13
5	<a href="#">Rear crossmember cut</a>	14
6	<a href="#">Rear crossmember</a>	17
7	<a href="#">Main floor cut</a>	24
8	<a href="#">Suspension modification</a>	26
9	<a href="#">Lowered floor</a>	35
10	<a href="#">How to seal</a>	40
11	<a href="#">Sealant</a>	46
12	<a href="#">3-point belt preparation</a>	49
13	<a href="#">TriflexAir seat bracket</a>	54
14	<a href="#">Wiring</a>	58
15	<a href="#">Floor LED preparation</a>	66
16	<a href="#">Fuel system install</a>	68
17	<a href="#">Exhaust install</a>	77
18	<a href="#">Cavity protection coating</a>	87
19	<a href="#">Bottom finished</a>	87
20	<a href="#">Upholstery</a>	88
21	<a href="#">Floor LED install</a>	91
22	<a href="#">3-point belt stalks</a>	93
23	<a href="#">Front retractors</a>	94
24	<a href="#">Front cover</a>	95
25	<a href="#">Finishing</a>	96
26	<a href="#">Parking sensors</a>	101
27	<a href="#">Interior panels</a>	106
28	<a href="#">3-point belt install</a>	110
29	<a href="#">Rear bumper support</a>	112
30	<a href="#">Ramp</a>	114
31	<a href="#">2nd row OEM seats</a>	126
32	<a href="#">3rd row TriflexAir seats</a>	126
33	<a href="#">Taillights</a>	134
34	<a href="#">Rear bumper</a>	135
35	<a href="#">Emergency exit</a>	146
36	<a href="#">Tailgate cover protection</a>	155
37	<a href="#">Rear retractors</a>	155
38	<a href="#">End of conversion</a>	158
39	<a href="#">Tightening torques</a>	159
40	<a href="#">Tools &amp; chemicals</a>	160



## IMPORTANT:

Keep all bolts & nuts!  
The steps where tectyl, glue and some where sealant is used require time to dry. in the meantime it's possible to do some steps that do not intervene with the drying process.  
Disconnect the battery during the conversion.

### Disassembly



Remove the tailgate panel.  
Be sure to keep all of the clips.

Disassembly



Remove the rear sill and lashing eyes.

Disassembly

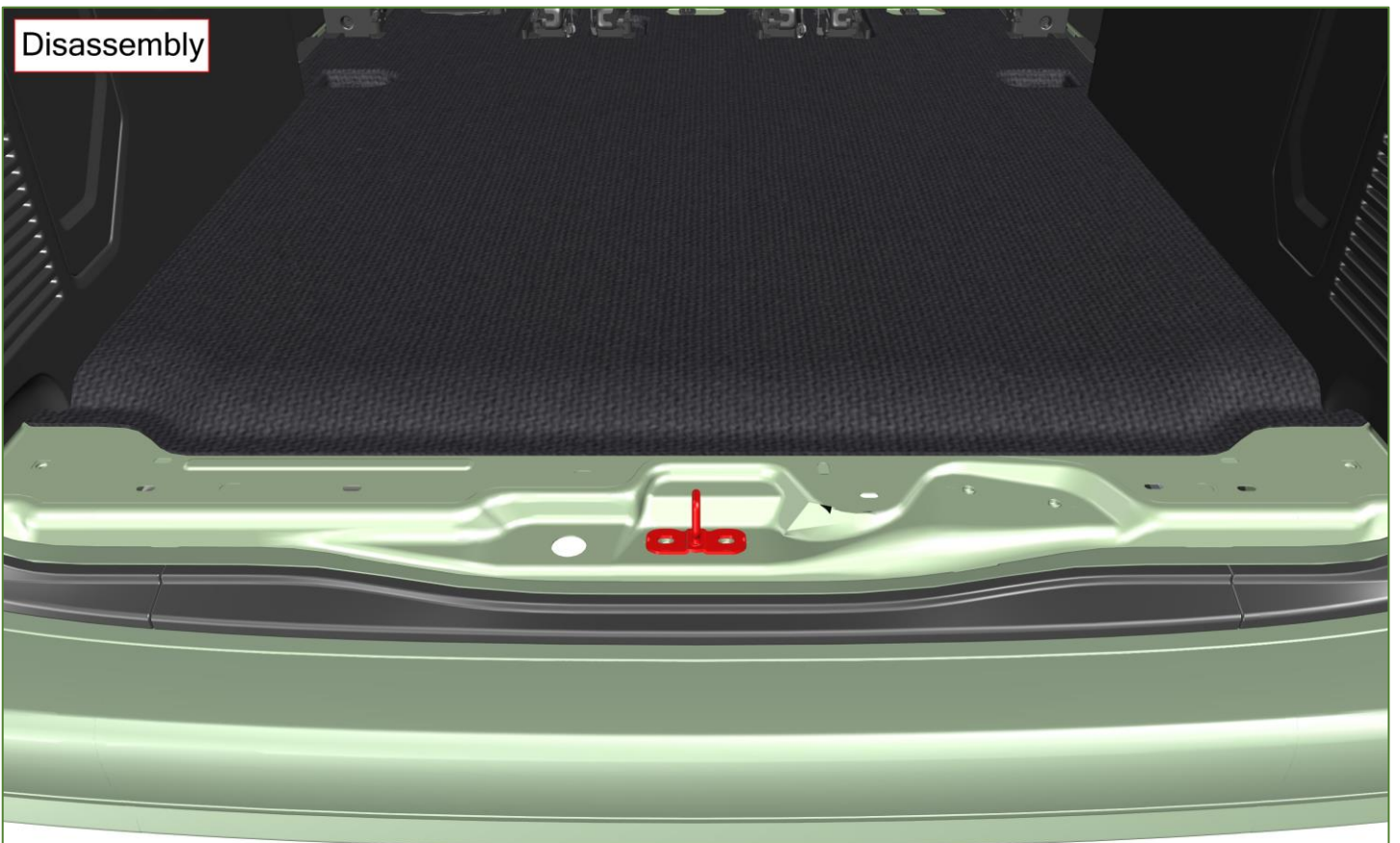

Remove the tailgate striker.

Disassembly



Take the seat out the rear of the vehicle.

Disassembly



Take out the floor mat.



Disassembly



Take out the interior panels and door rubbers.

Disassembly



Take out the top interior panels and door sills.  
Pull aside the cables on the floor.

Disassembly

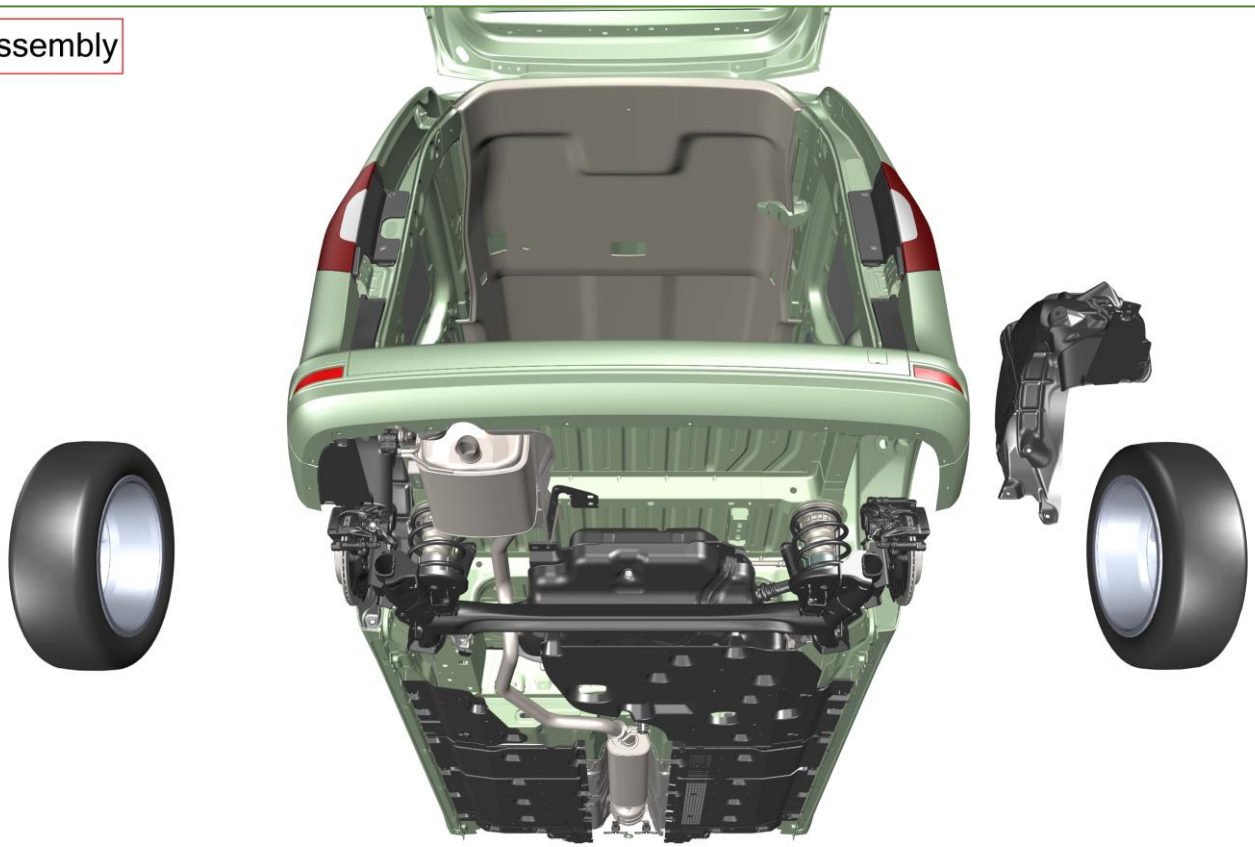

Remove the rear wheels and the right side wheelarch.

Disassembly



Remove the taillights, rear bumper and plastic covers. Move aside the keyless entry unit.

Disassembly

120 mm

Cut the inner bumper as shown.

Disassembly

Take off the inner bumper corners.



## Disassembly

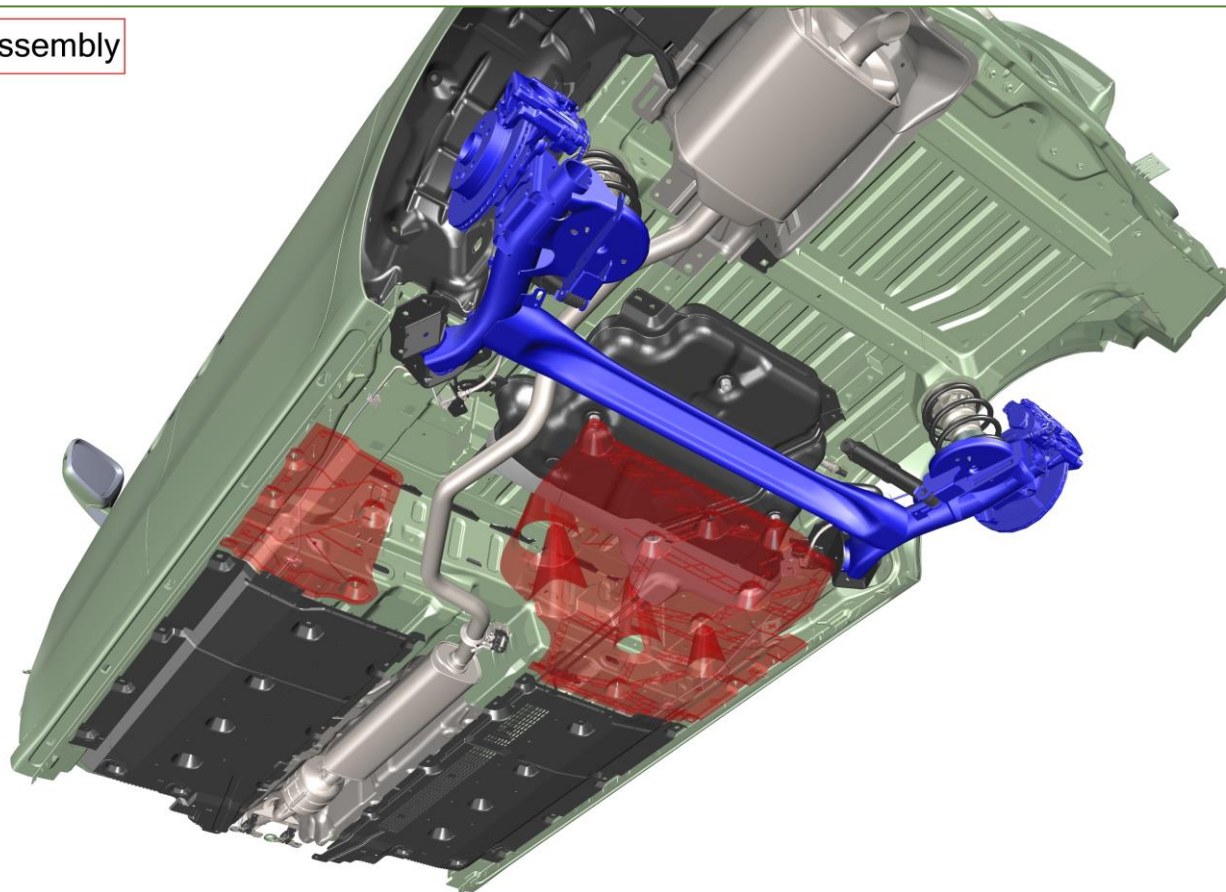

Take off the marked plastic covers.  
Also remove the plastic cover on the rear axle. Don't keep this.

## Exhaust Disassembly

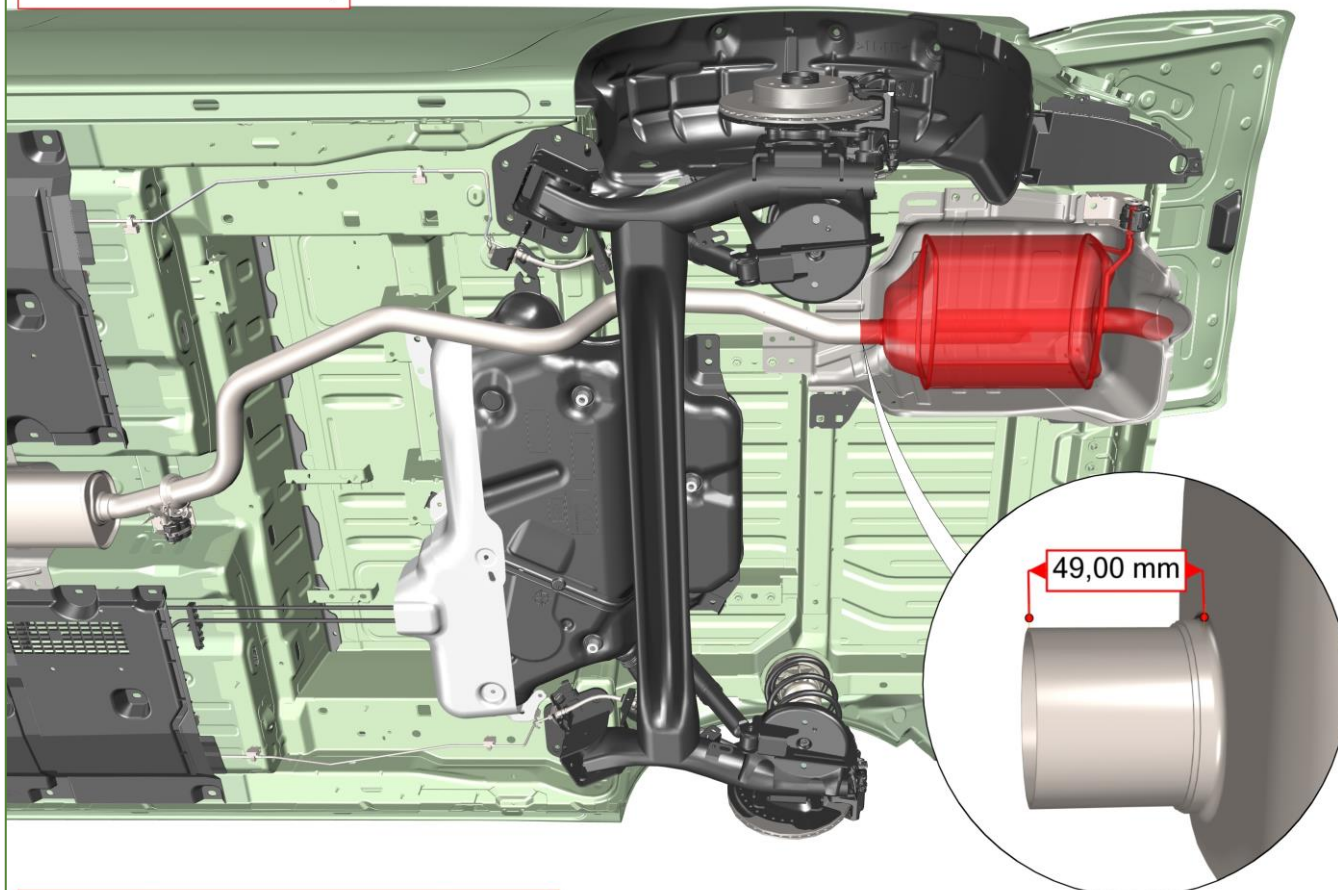

Cut off and remove the rear muffler.



## Exhaust Disassembly

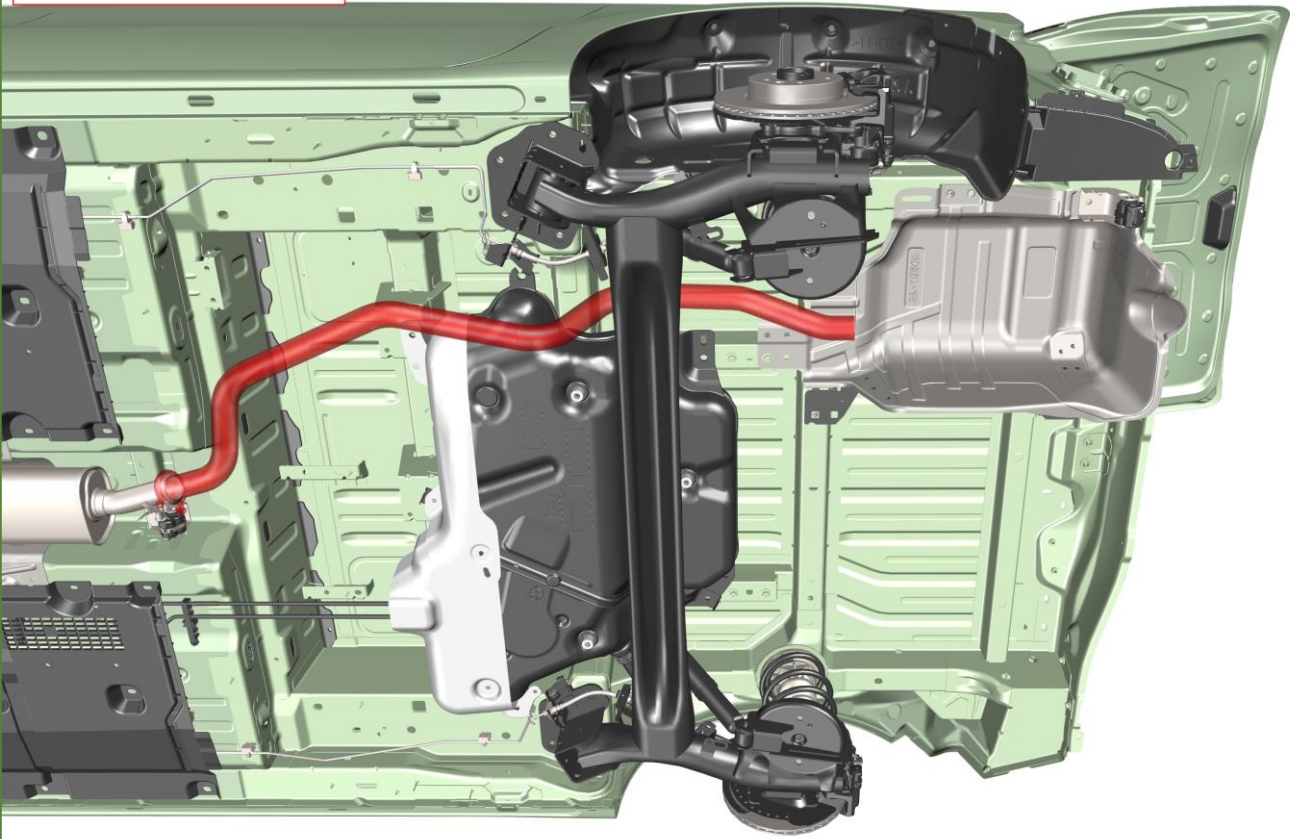

Remove the rest of this pipe with the clamp.

## Exhaust Disassembly

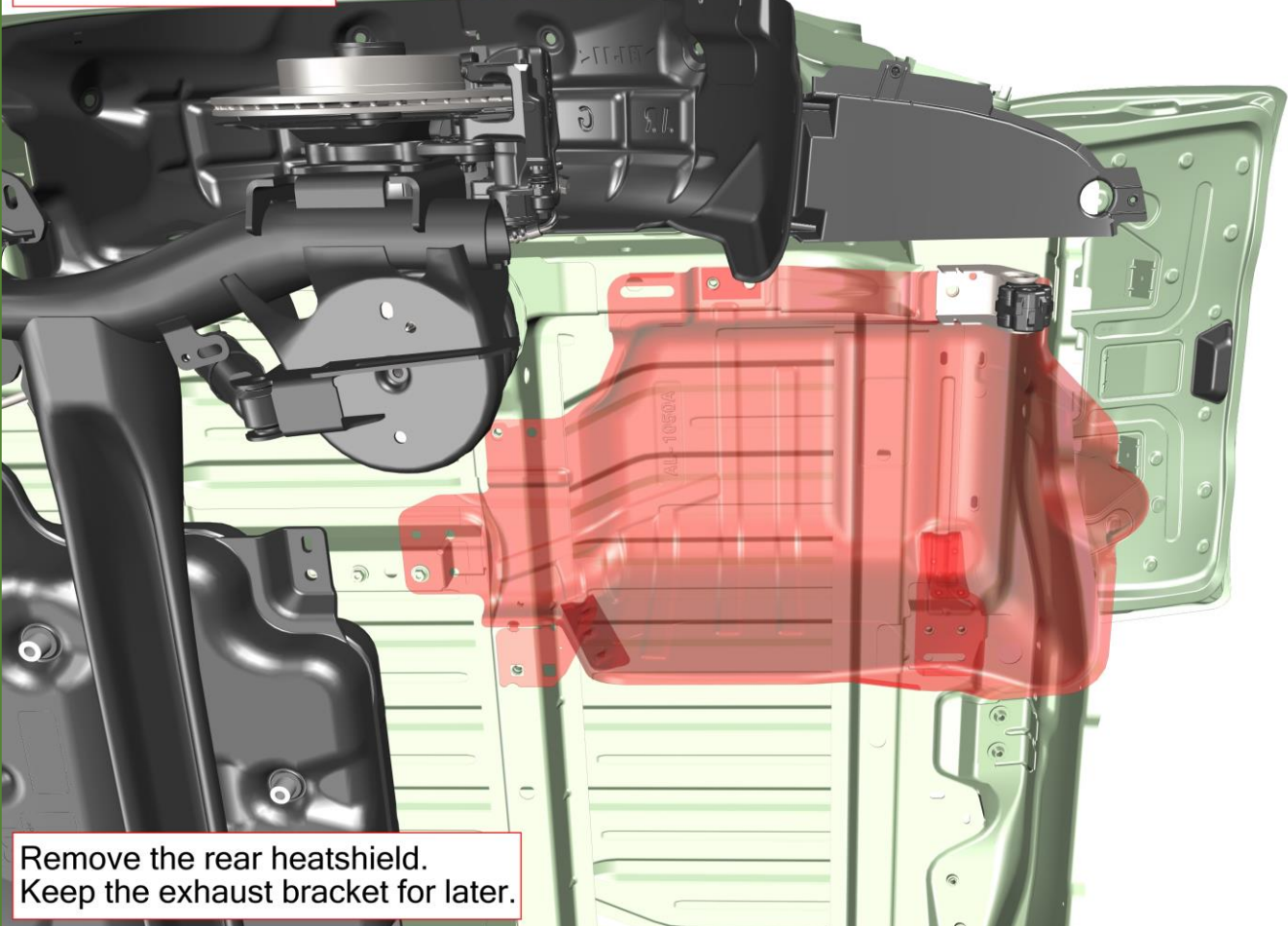

Remove the rear heatshield.  
Keep the exhaust bracket for later.

## Fuel system disassembly

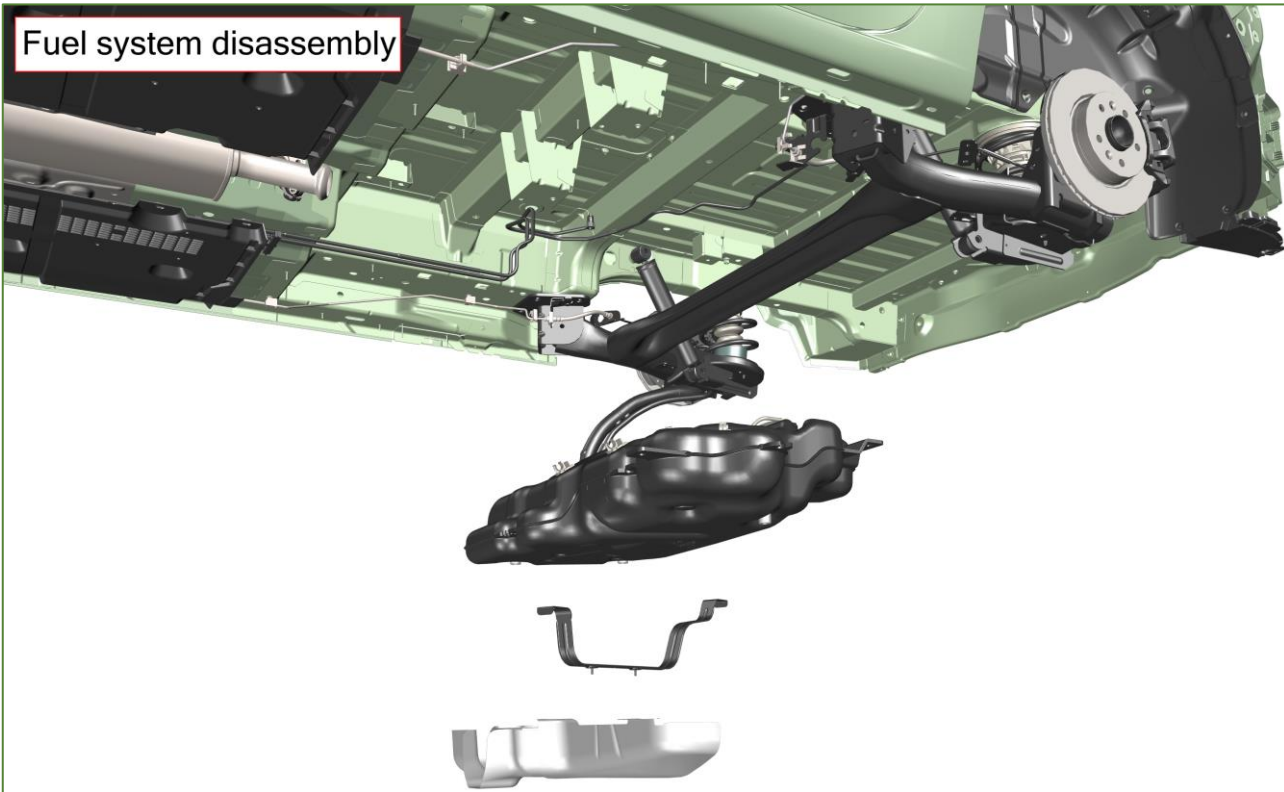

Make sure the fuel tank is empty.  
Take off the fuel tank shield+bracket and lower the fuel tank.  
Disconnect the fuel lines and pull the breather hose aside.

## Fuel system disassembly

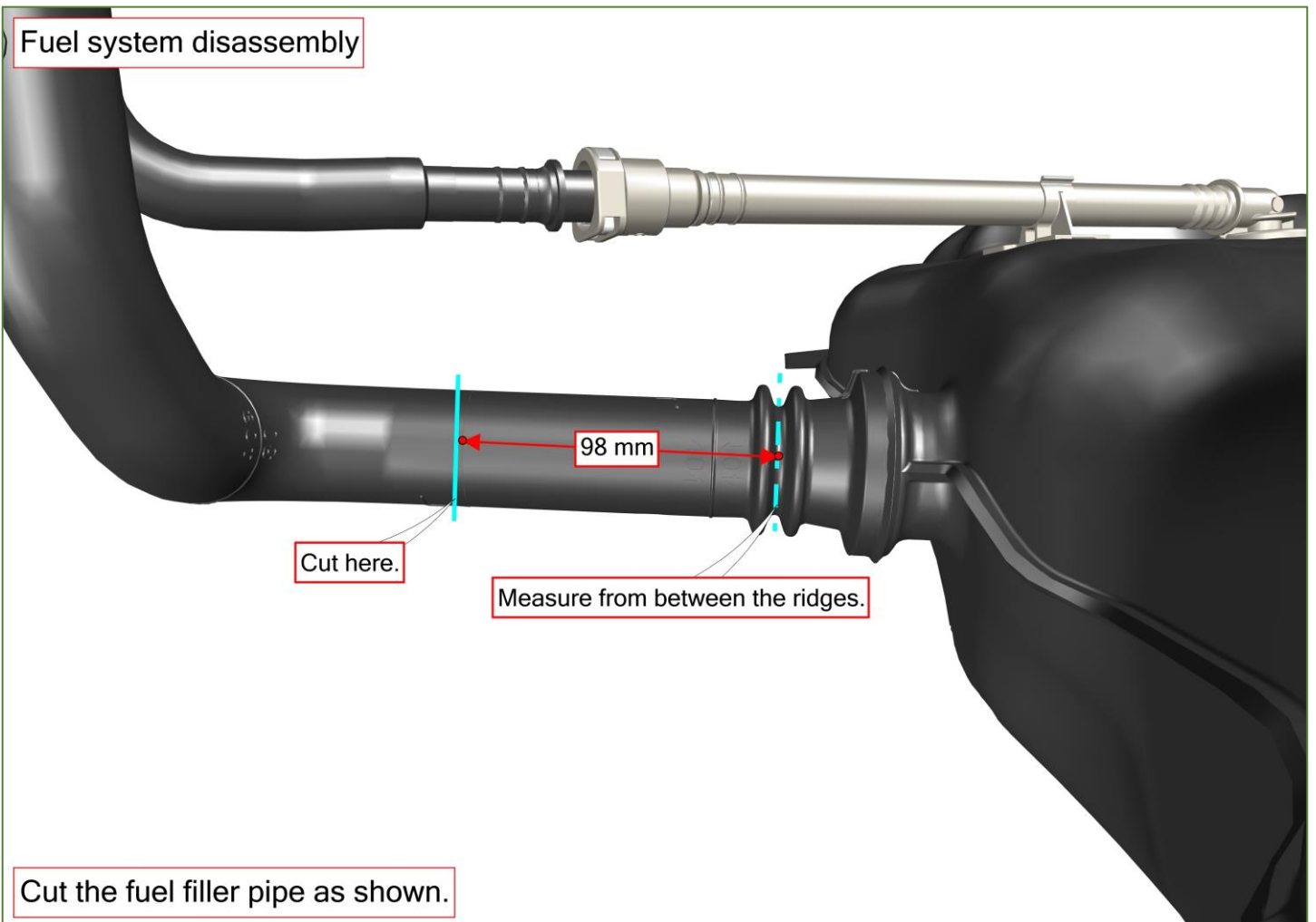

Cut the fuel filler pipe as shown.



## Fuel system disassembly

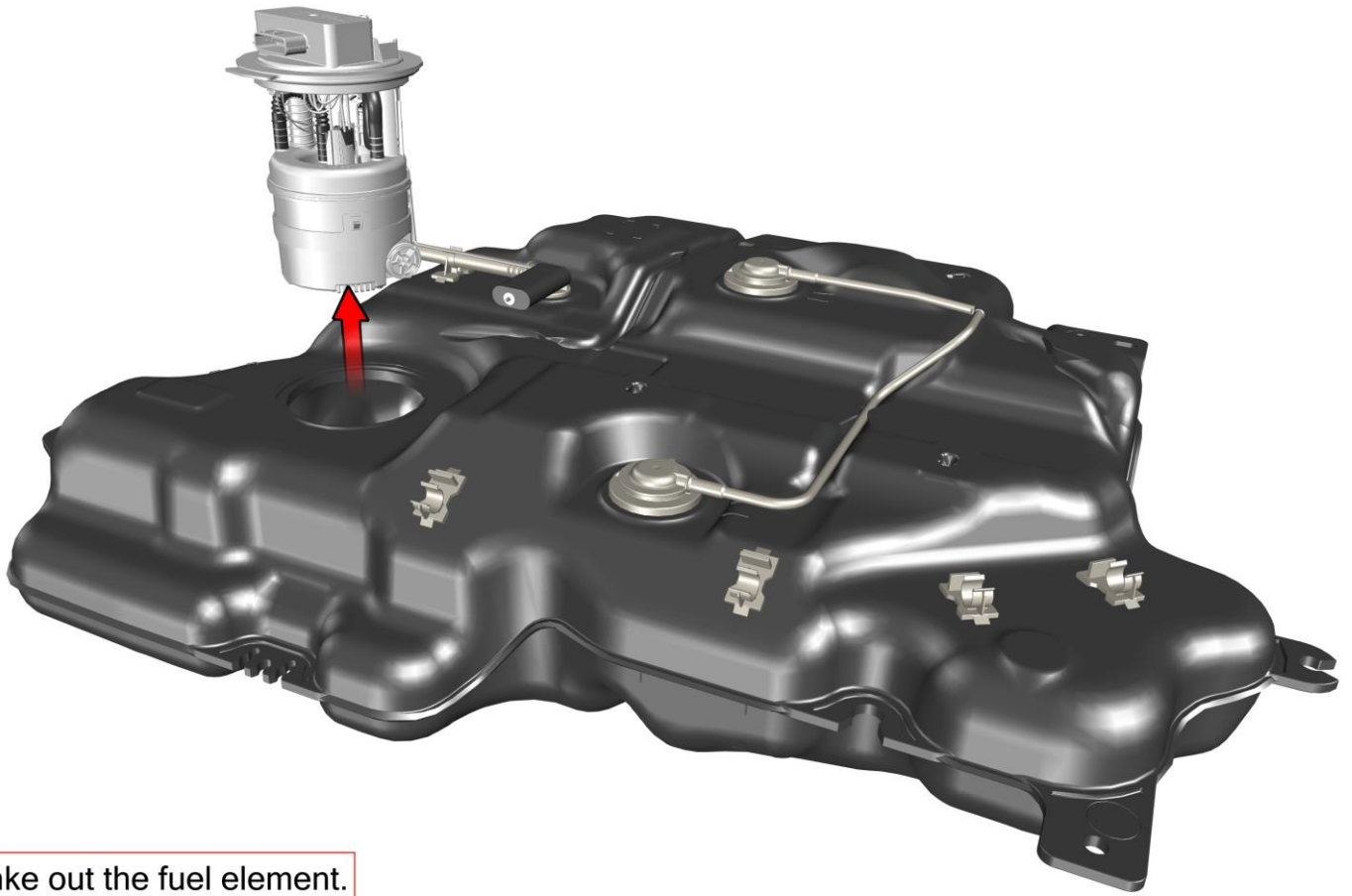

Take out the fuel element.

## Fuel system disassembly

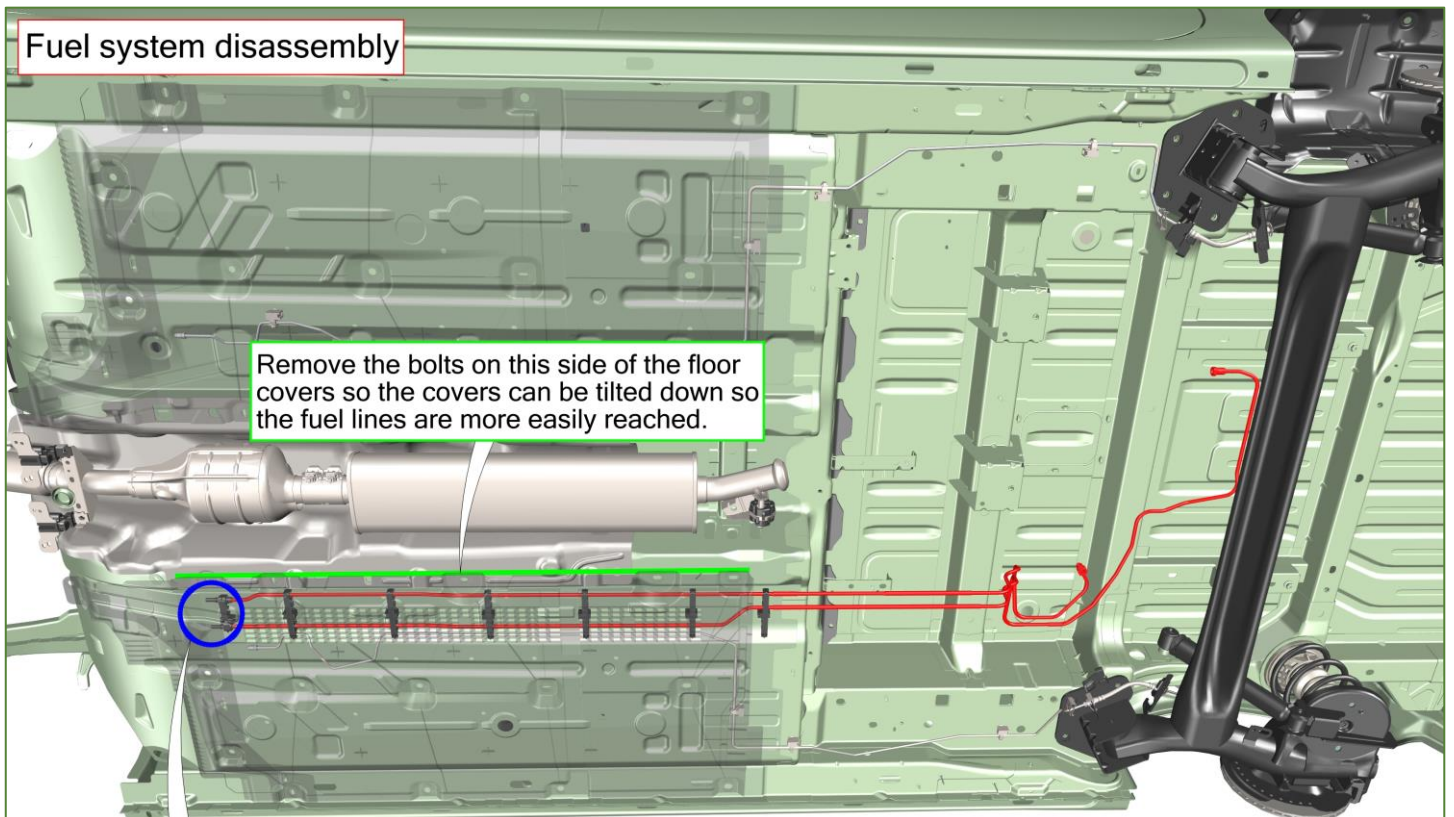

Remove the bolts on this side of the floor covers so the covers can be tilted down so the fuel lines are more easily reached.

The fuel lines can be disconnected here.

Remove the fuel lines.

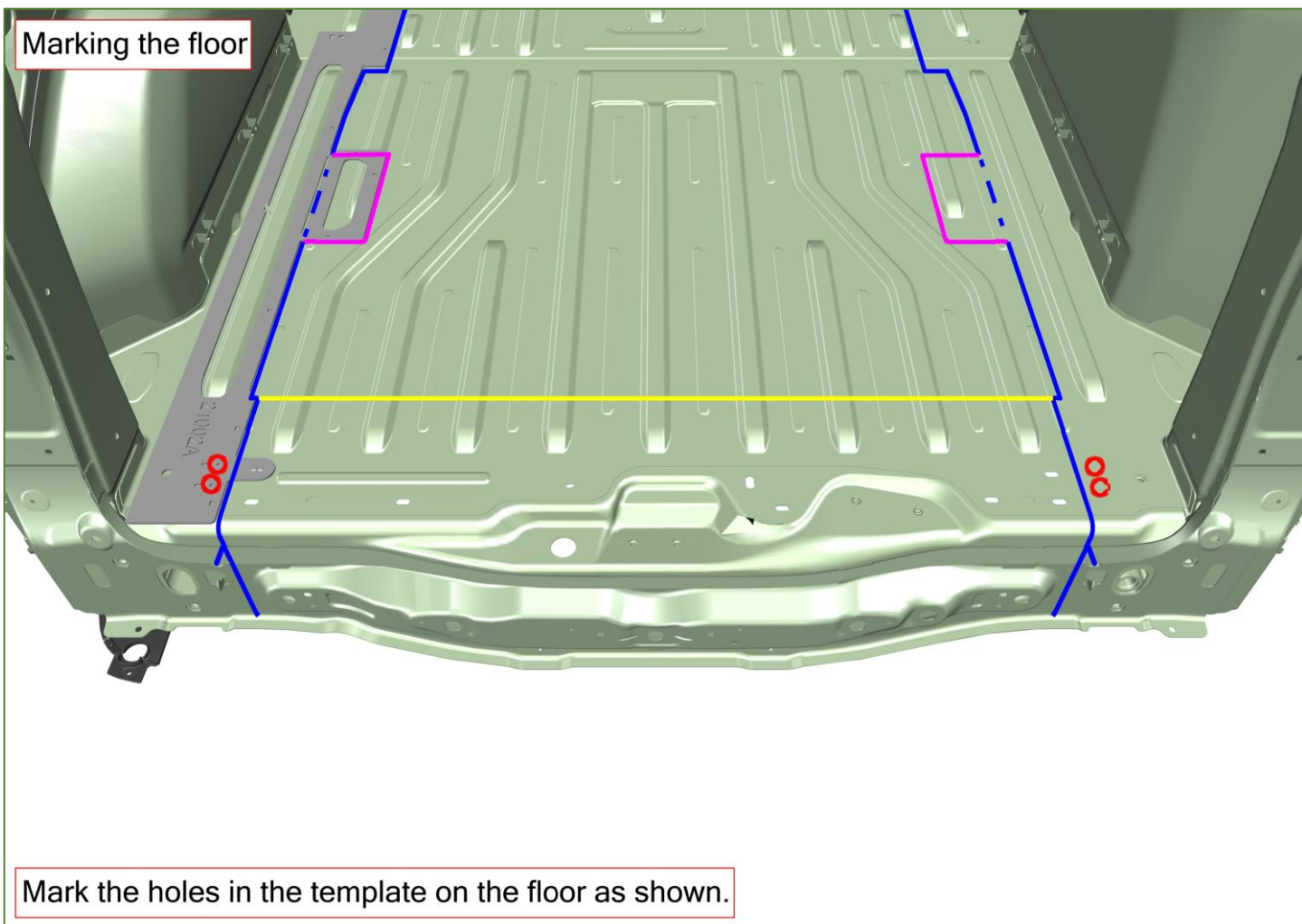
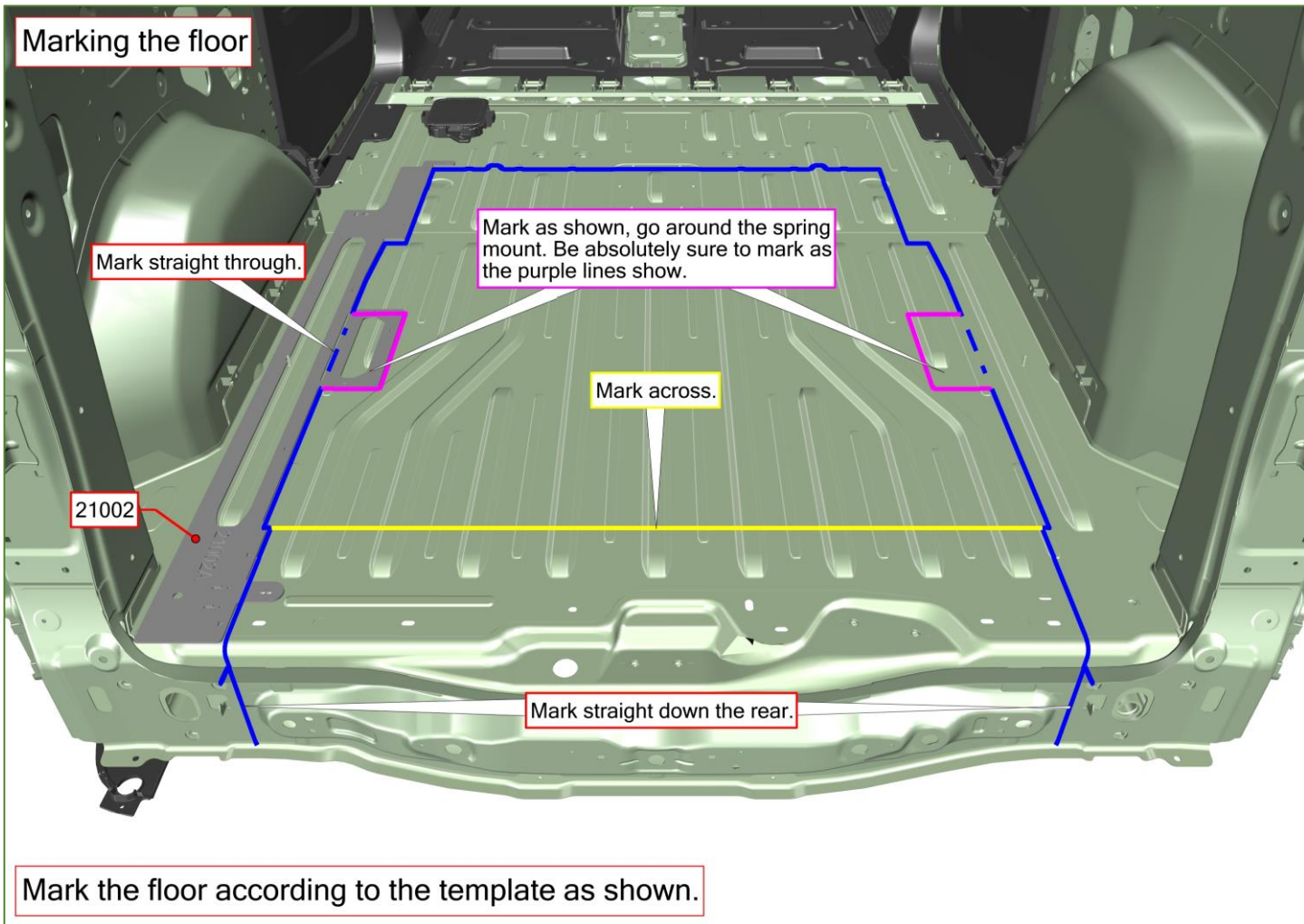



Rear crossmember cut

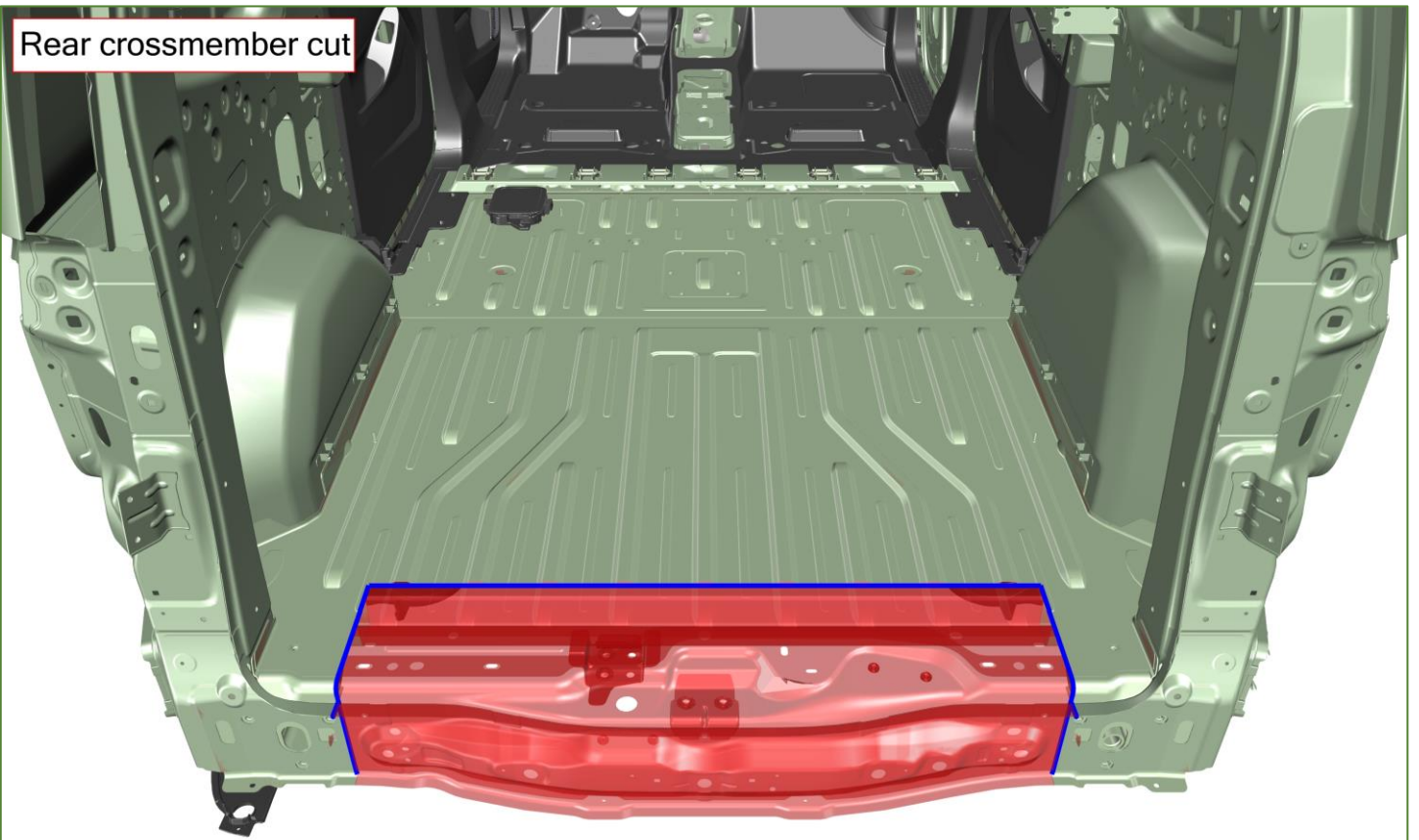

Cut the first part of the floor as shown.

Rear crossmember cut

Remove this clip or use a hammer do flatten it.

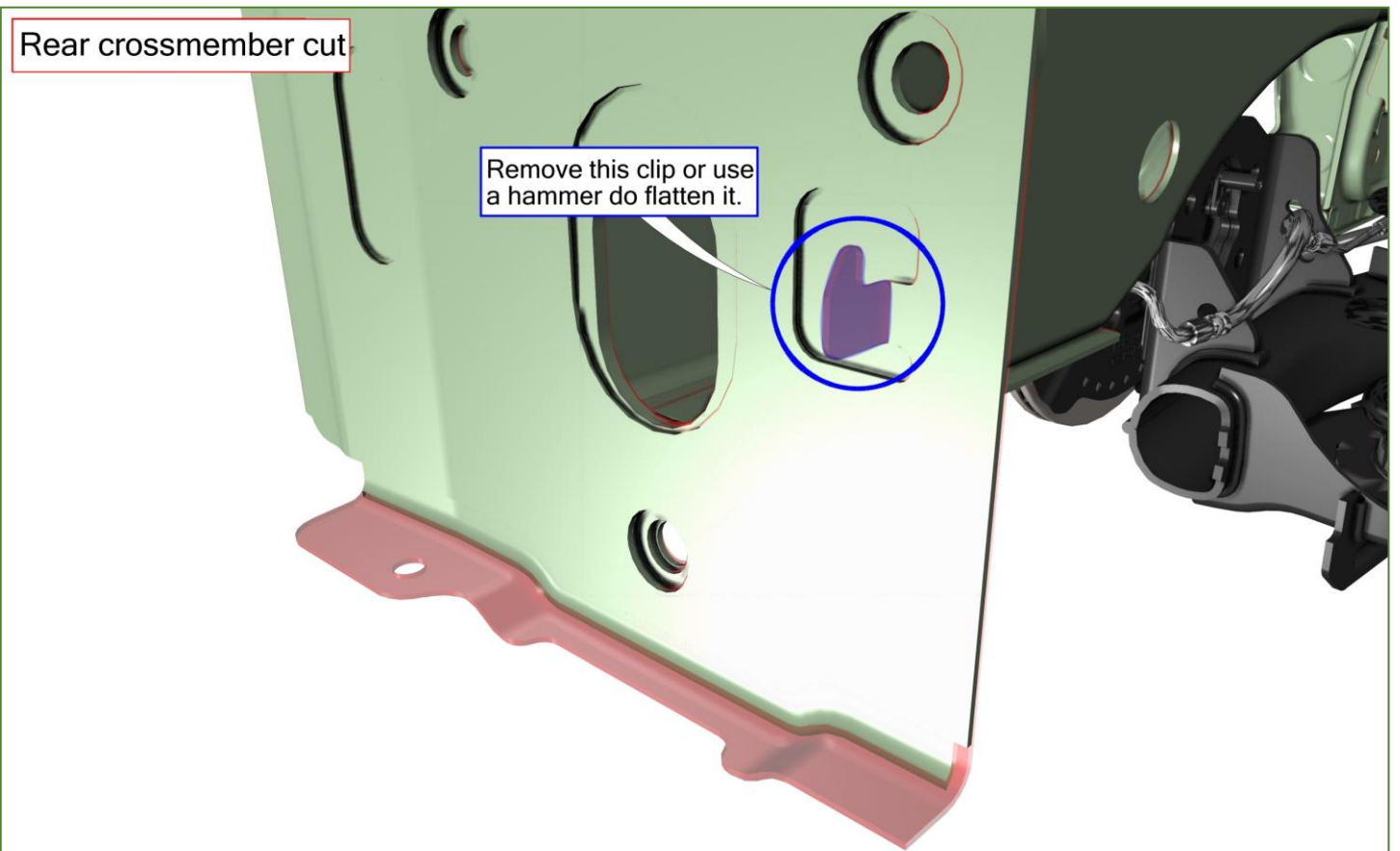

Cut this flap off on both sides.

Rear crossmember cut

Remove this flap.

Remove the leftovers from this beam on both sides.

Rear crossmember cut

Drill the marked holes  $\varnothing 10\text{mm}$  and thread M12.

Rear crossmember cut

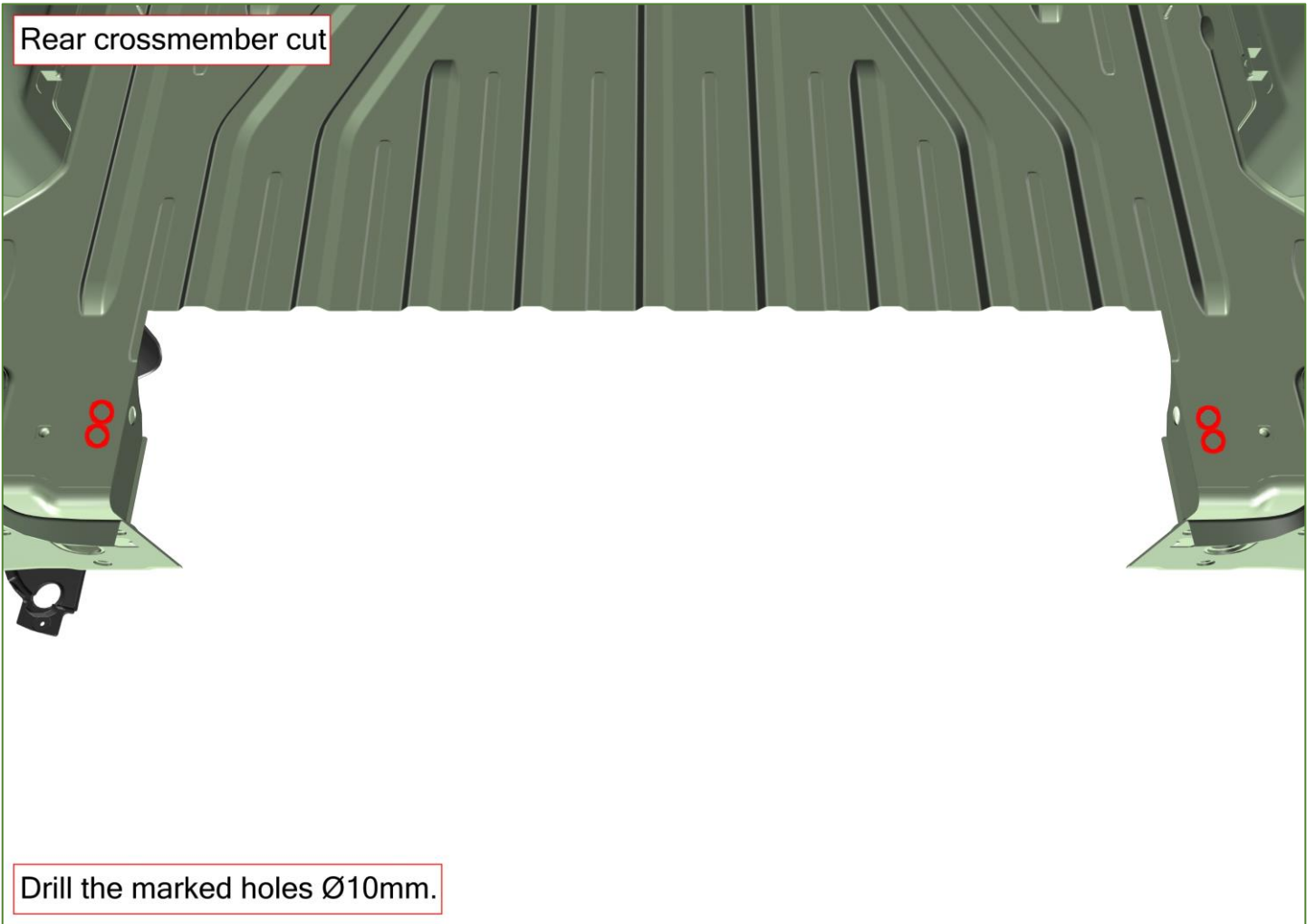

Drill the marked holes Ø10mm.

Rear crossmember cut

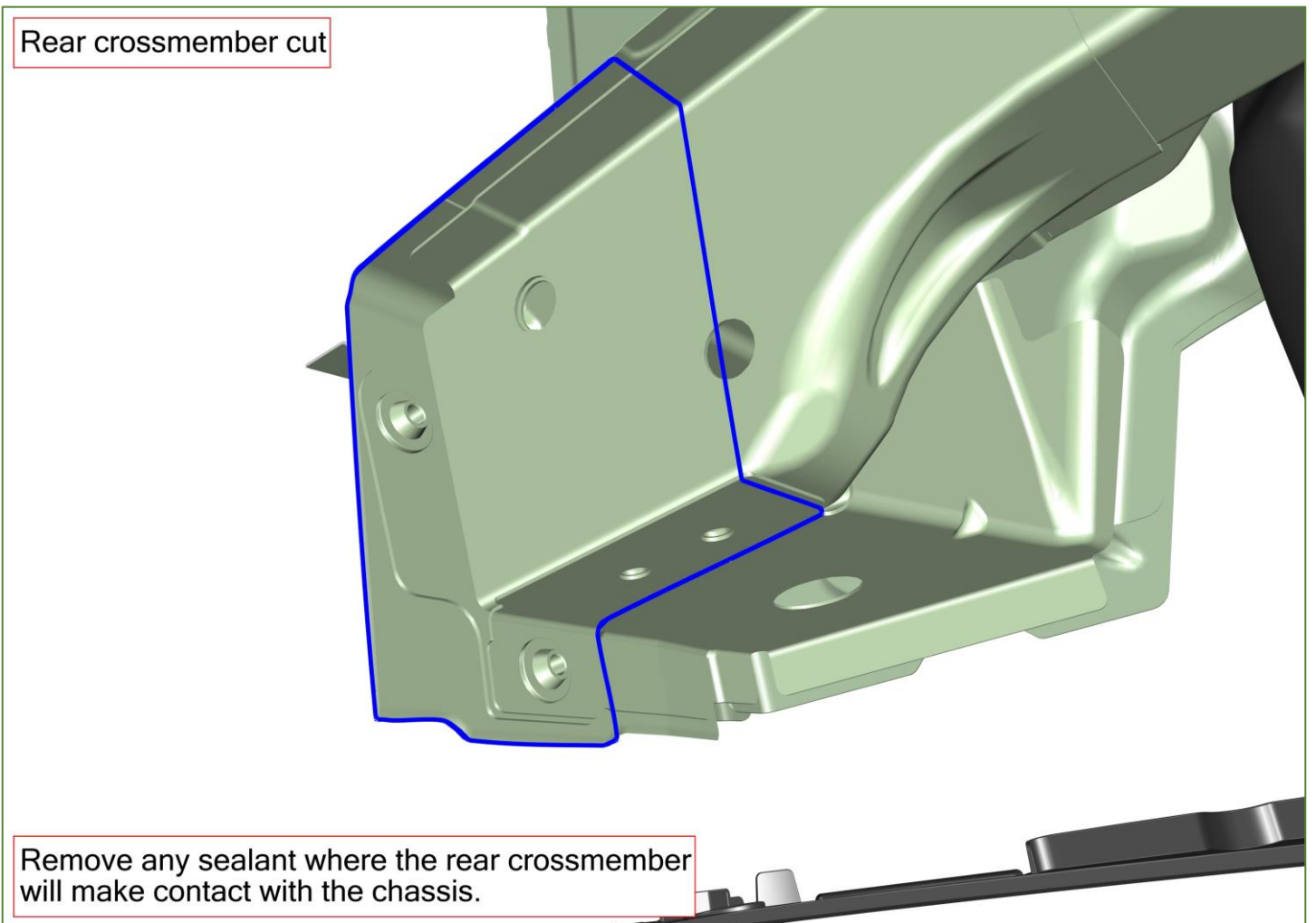

Remove any sealant where the rear crossmember will make contact with the chassis.



Rear crossmember cut

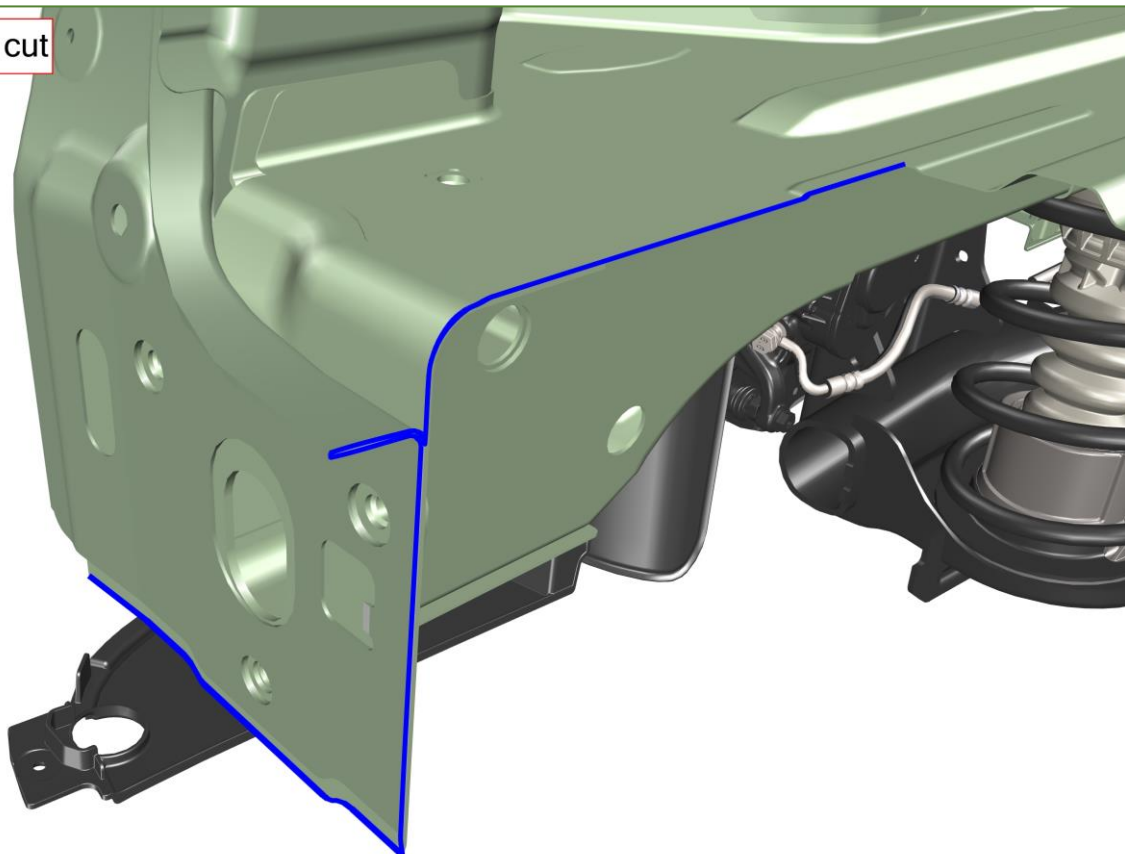

Apply anti corrosion paint on all bare metal edges and surfaces.

Rear crossmember



On top of the rear crossmember:  
Rethread the welded nuts on the mounting points.

Rear crossmember

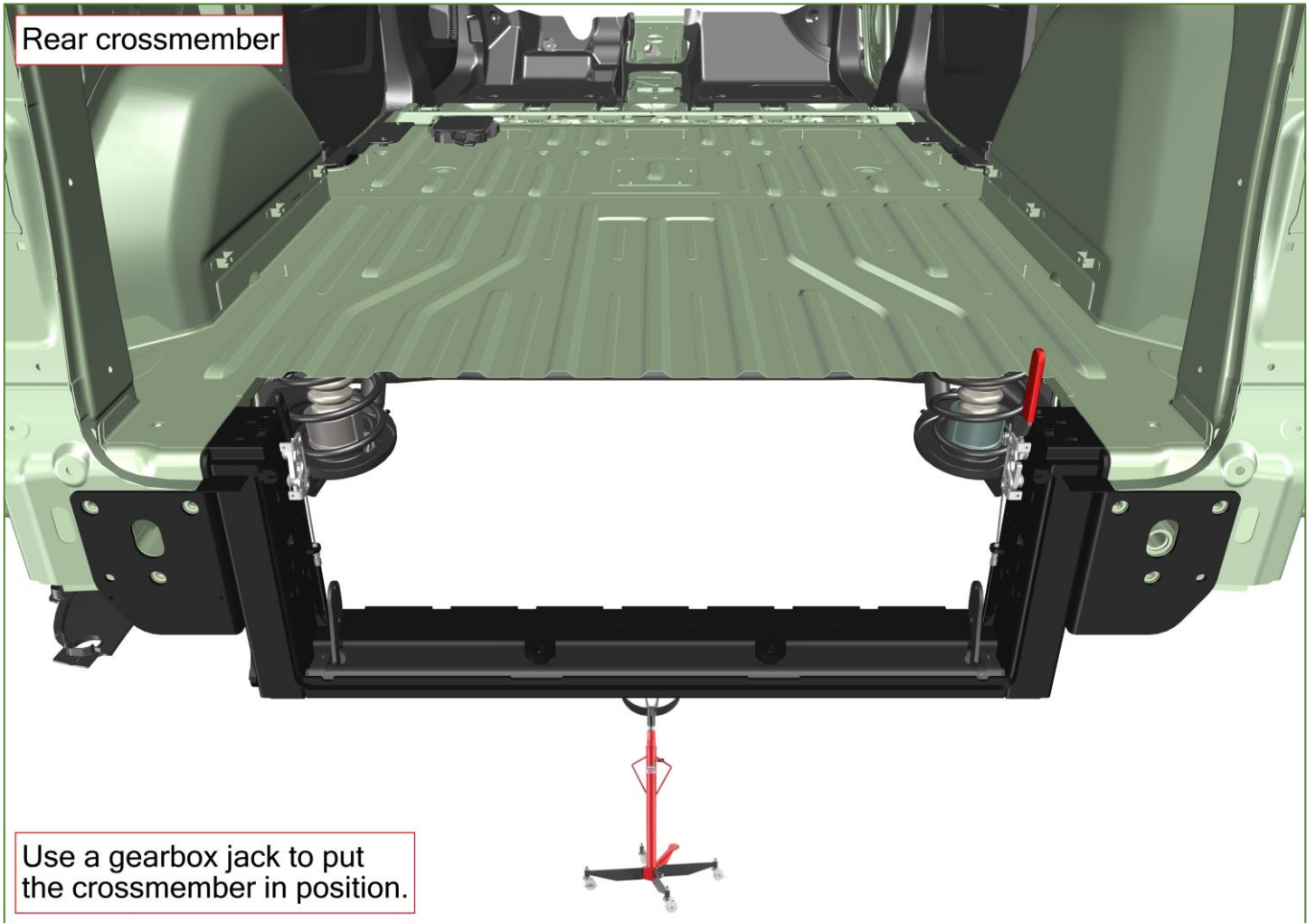

Use a gearbox jack to put the crossmember in position.

Rear crossmember

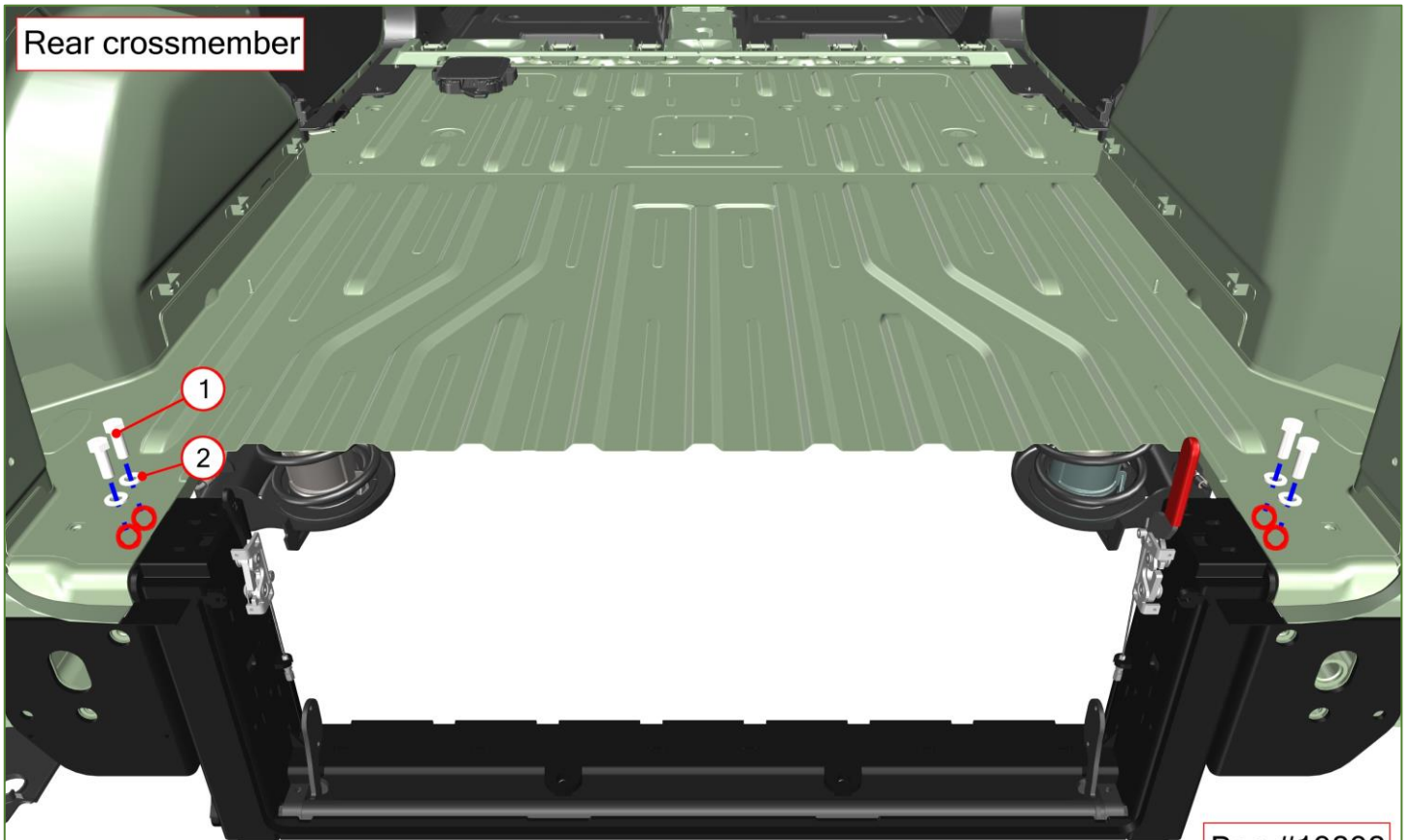

Bag #19898

Mount the top of the crossmember.

NO.	QTY	PART	DESCRIPTION
1	4	1256	Hex bolt M10x30 8.8
2	4	173	Washer M10 8.8

Rear crossmember

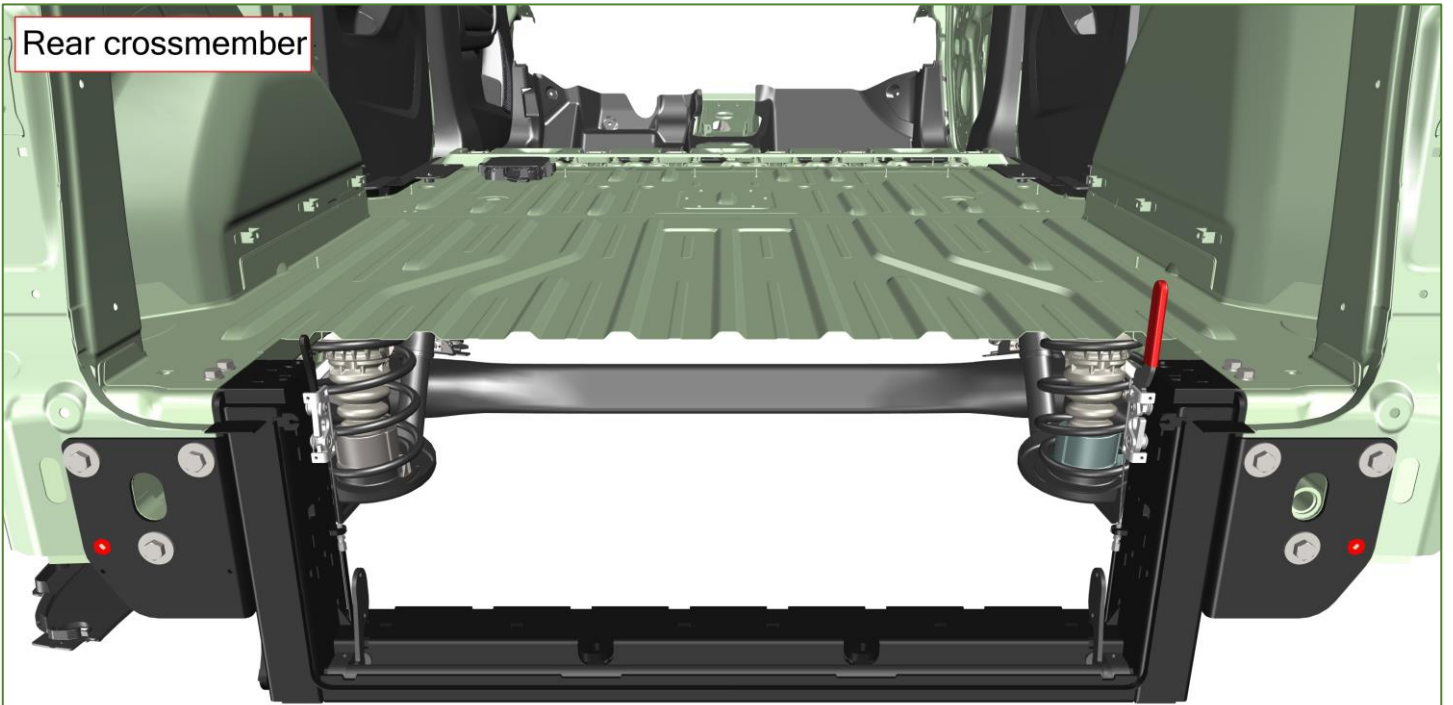

Temporarily mount the rear side to secure correct position.  
Drill the marked holes  $\text{\O}12\text{mm}$ .  
Take the bolts out after drilling.

Rear crossmember

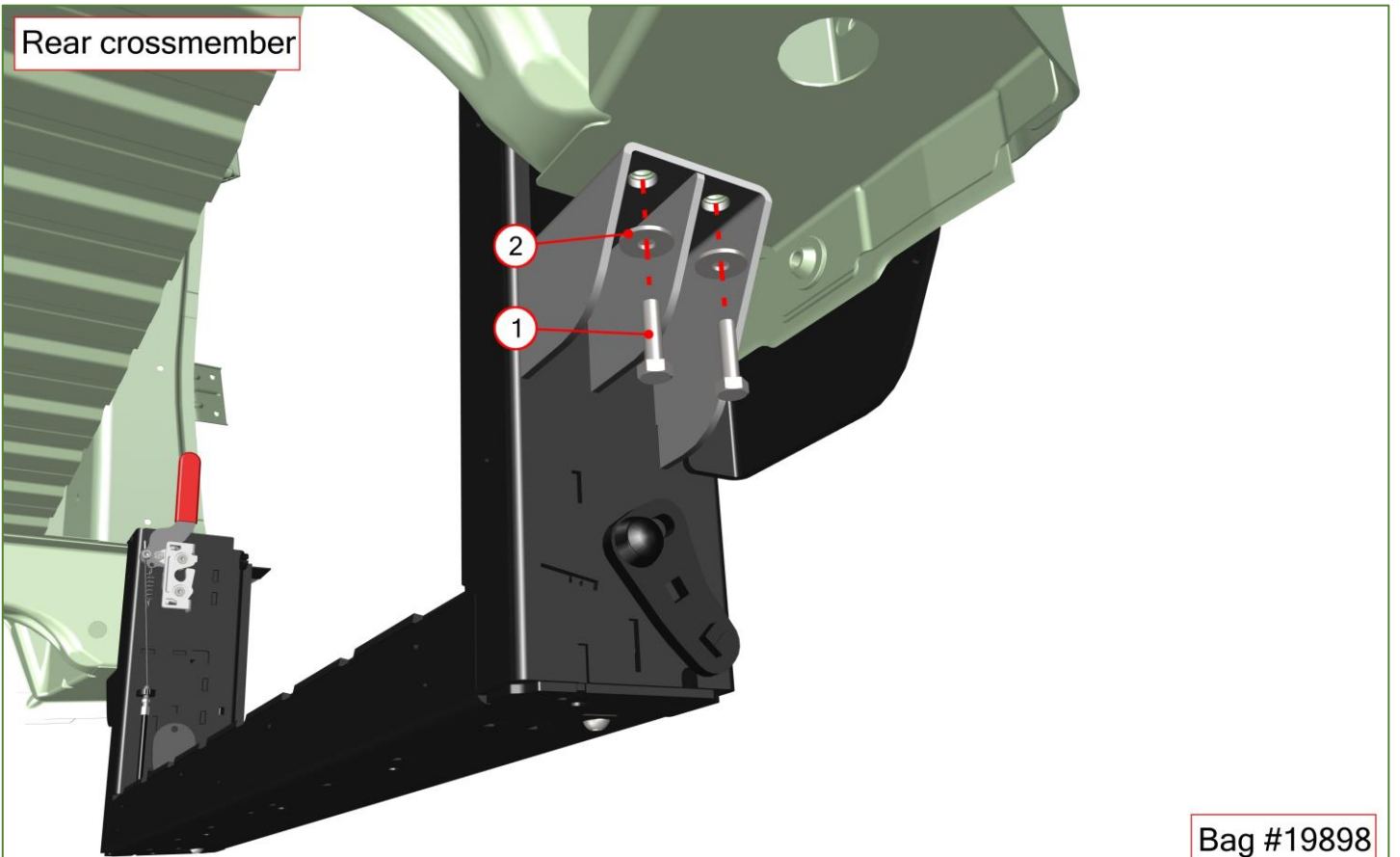

Bag #19898

Mount the LEFT side of the crossmember as shown.

NO.	QTY	PART	DESCRIPTION
1	2	824	Hex bolt M8x30 8.8
2	2	1246	Large washer M8 8.8



Rear crossmember

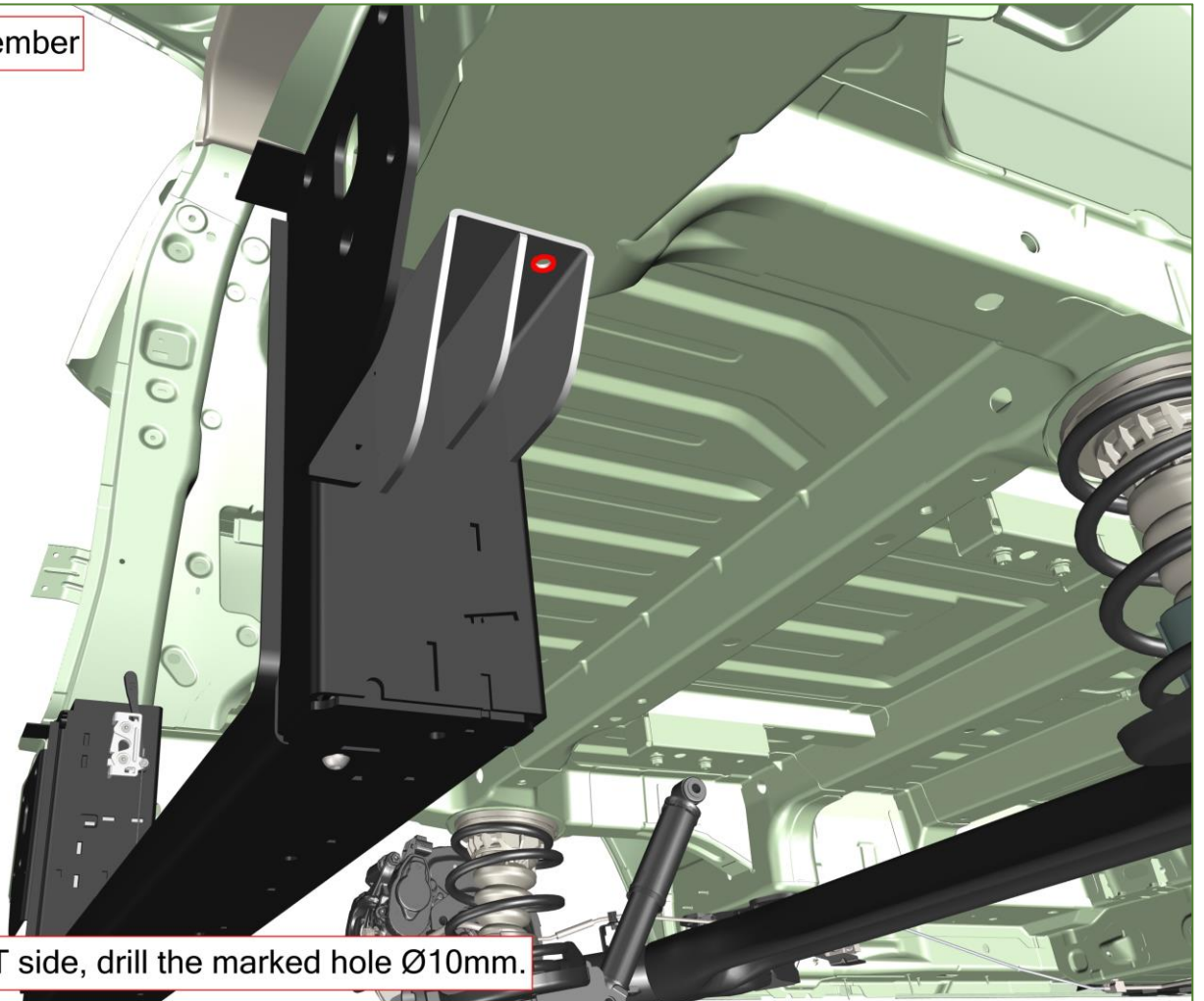

On the RIGHT side, drill the marked hole Ø10mm.

Rear crossmember

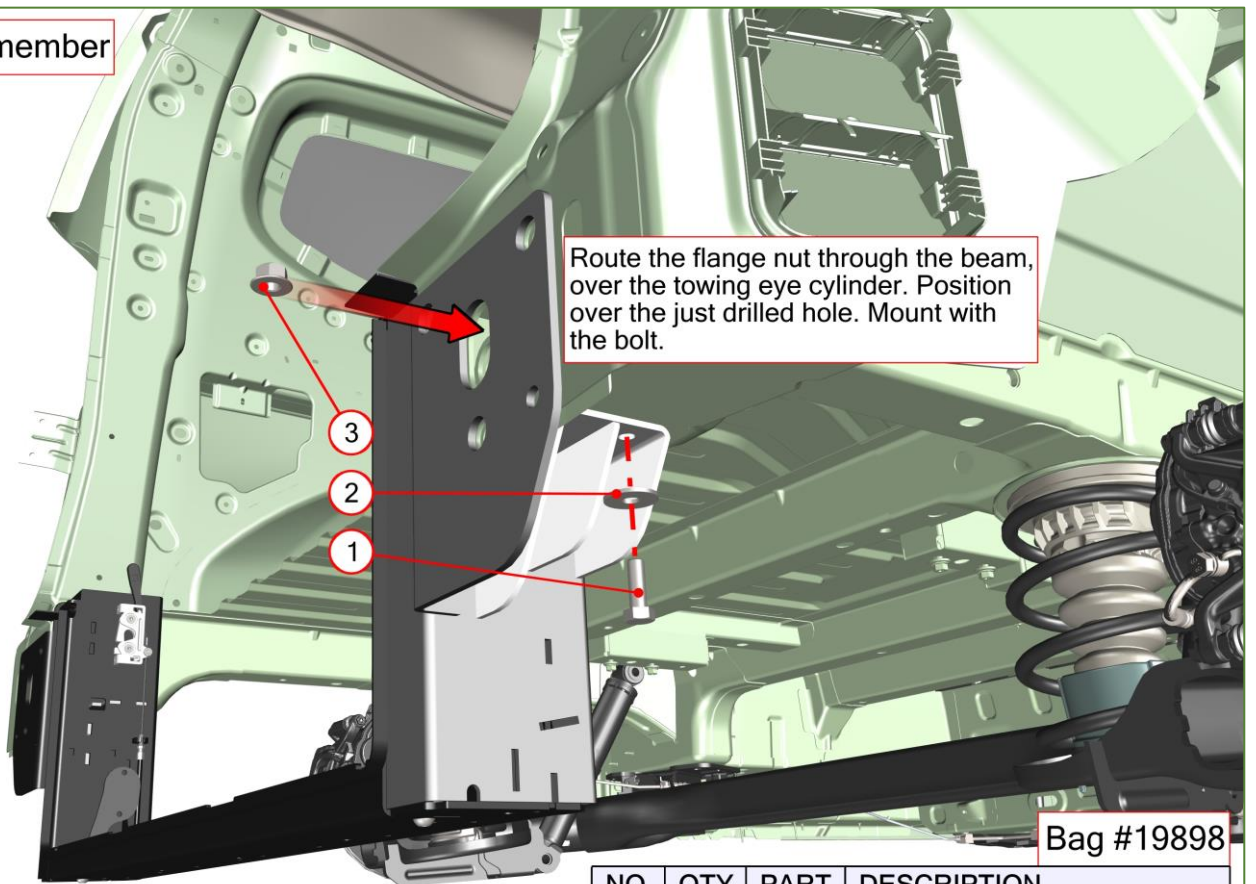

Route the flange nut through the beam, over the towing eye cylinder. Position over the just drilled hole. Mount with the bolt.

Bag #19898

NO.	QTY	PART	DESCRIPTION
1	1	1256	Hex bolt M10x30 8.8
2	1	181	Large washer M10x30x2.5 8.8
3	1	11339	Hex flange nut M10 10.9

Mount the RIGHT side as shown.

Rear crossmember

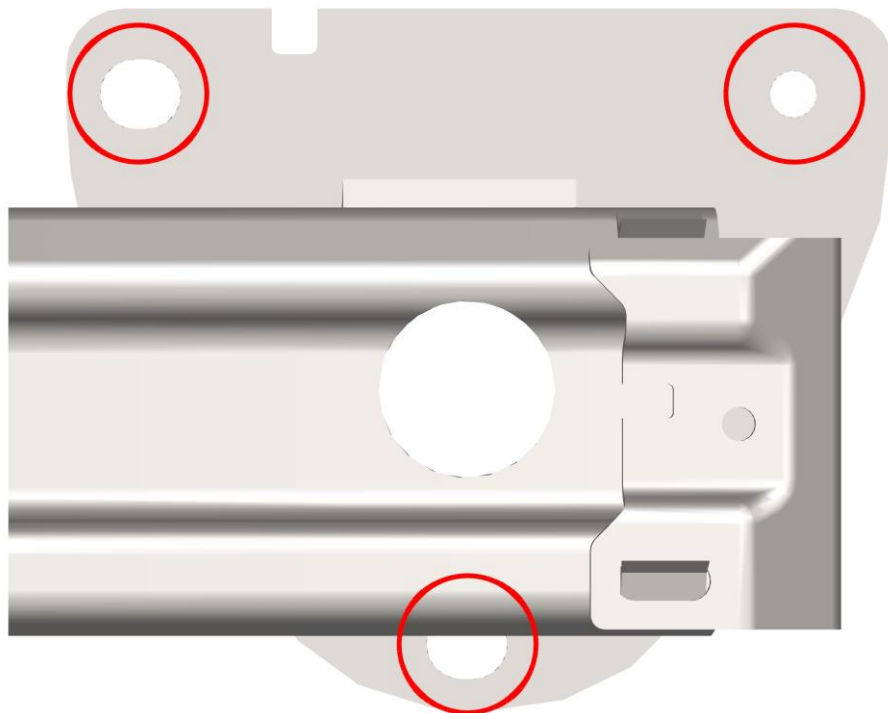

On the inner bumper corners:  
Drill the marked holes up to Ø14mm.

Rear crossmember

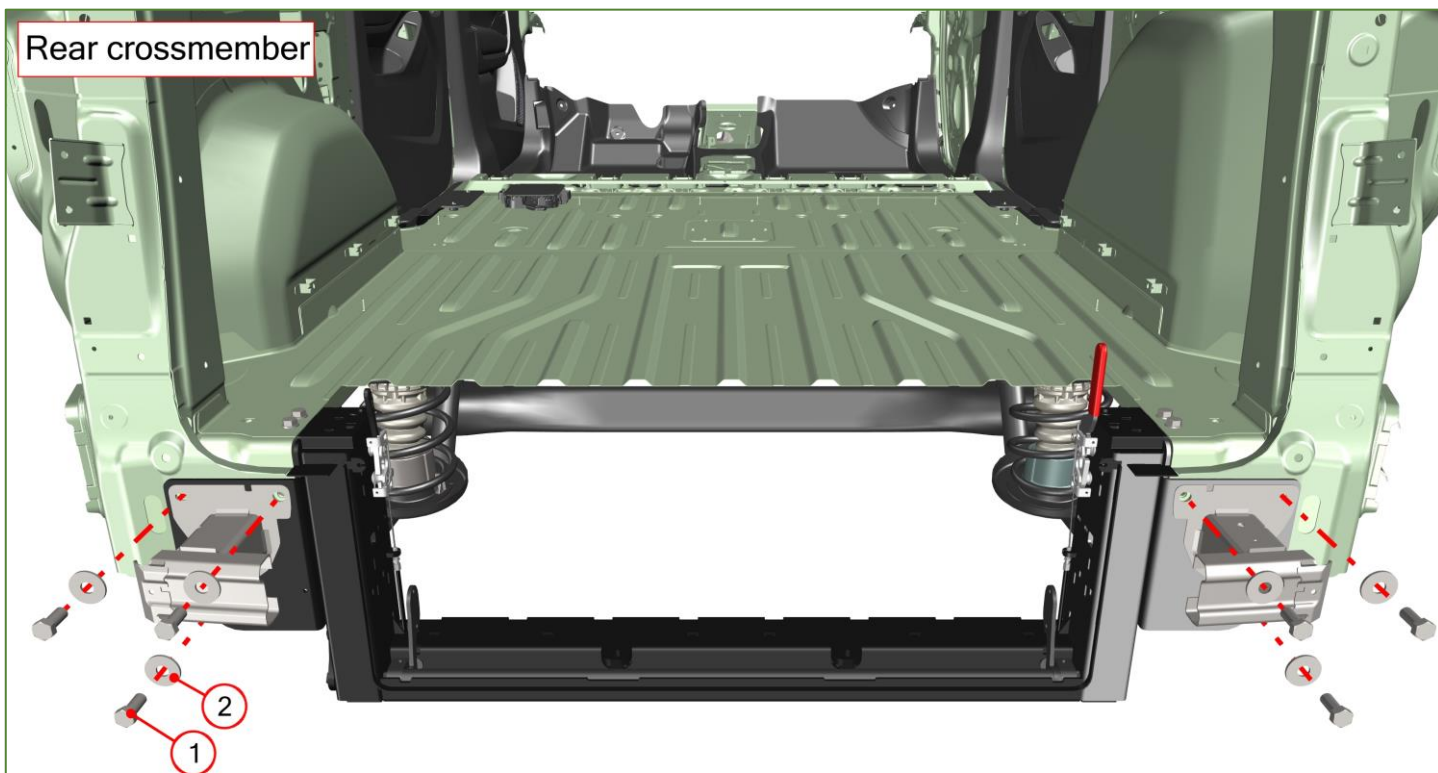

Bag #19898

Place the OEM inner bumper corners on the crossmember. Mount the back of the crossmember.

NO.	QTY	PART	DESCRIPTION
1	6	11335	Hex bolt M12x30 10.9
2	6	7209	Large washer M12x36x3 8.8

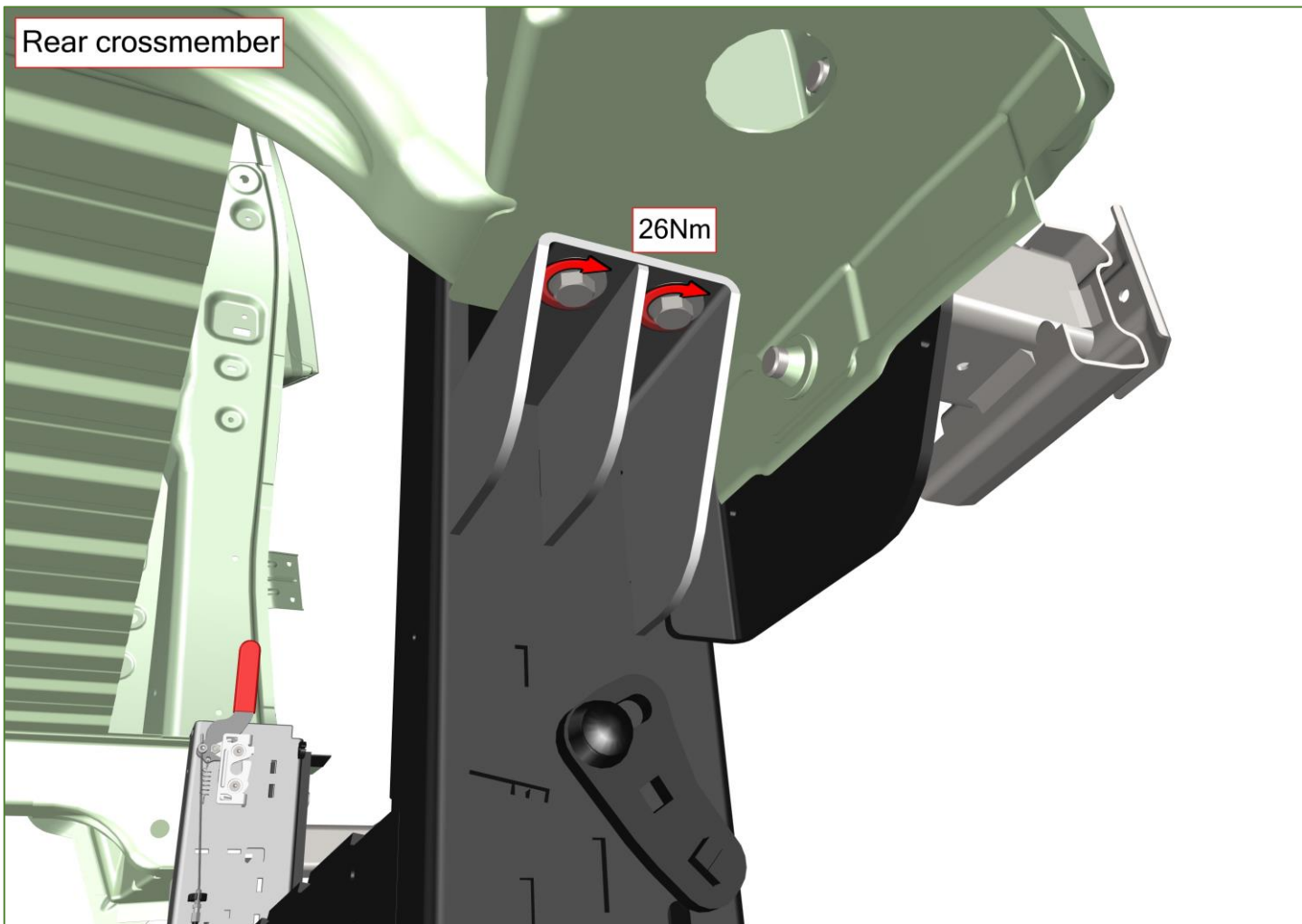
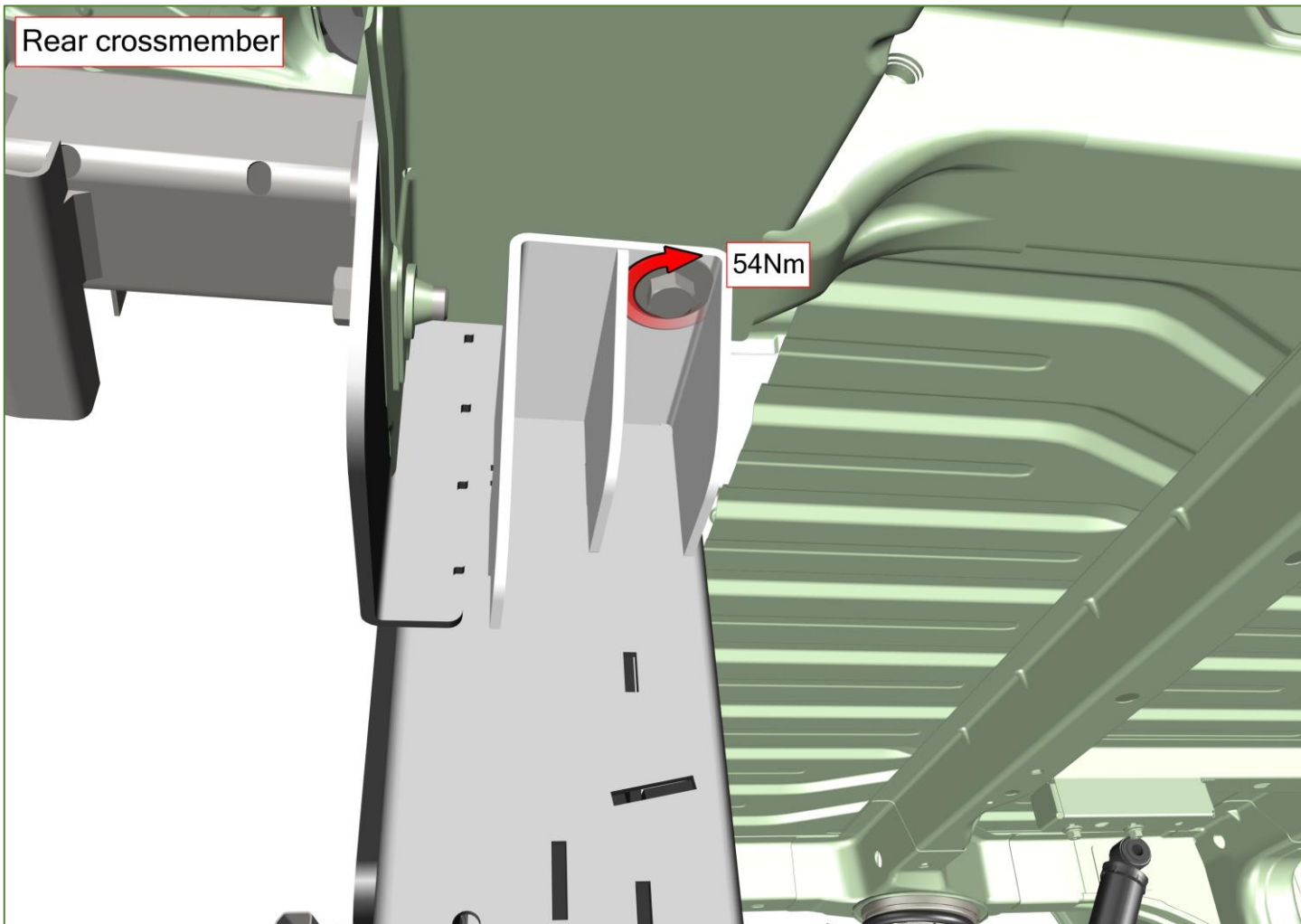



Rear crossmember

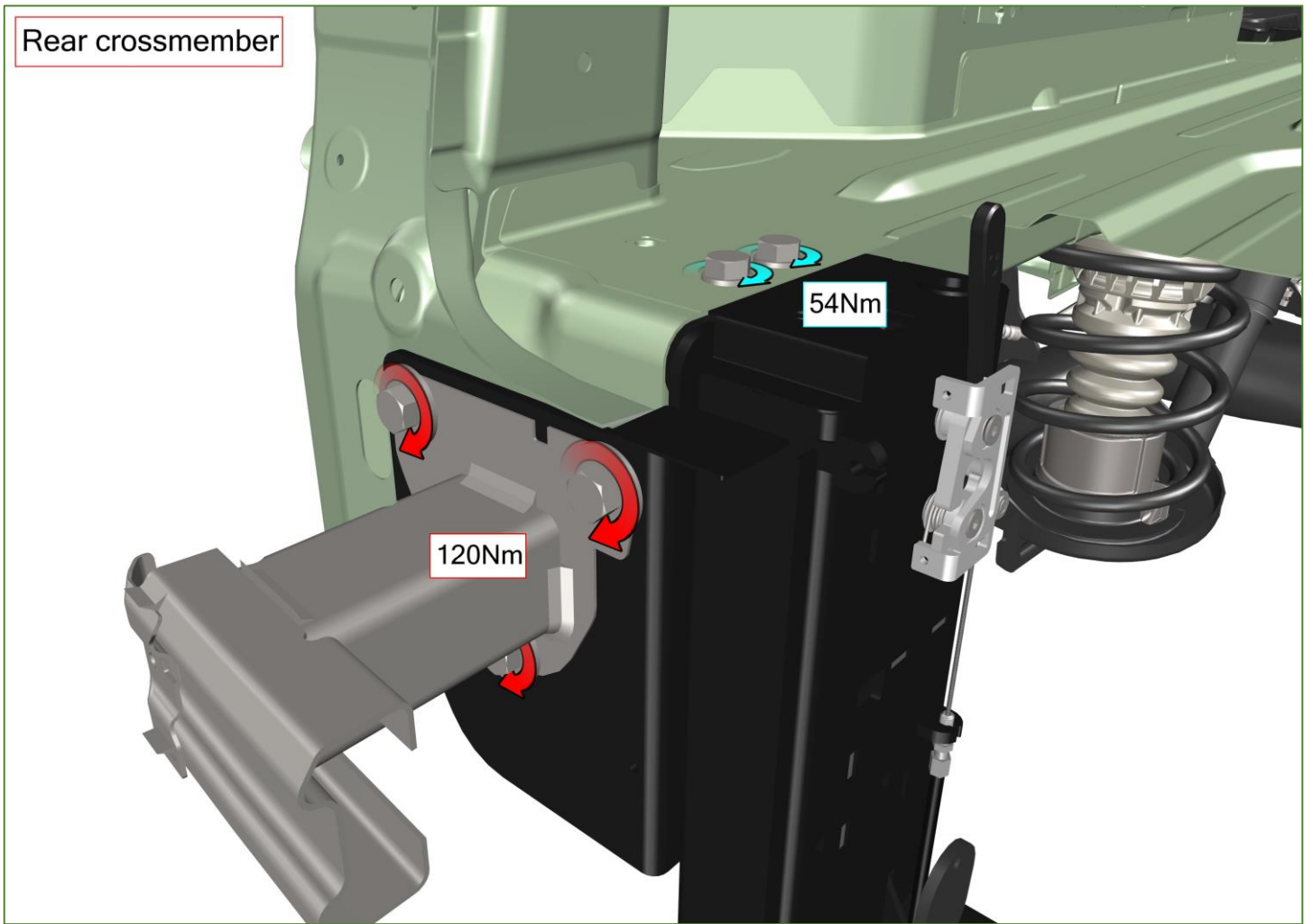

Rear crossmember

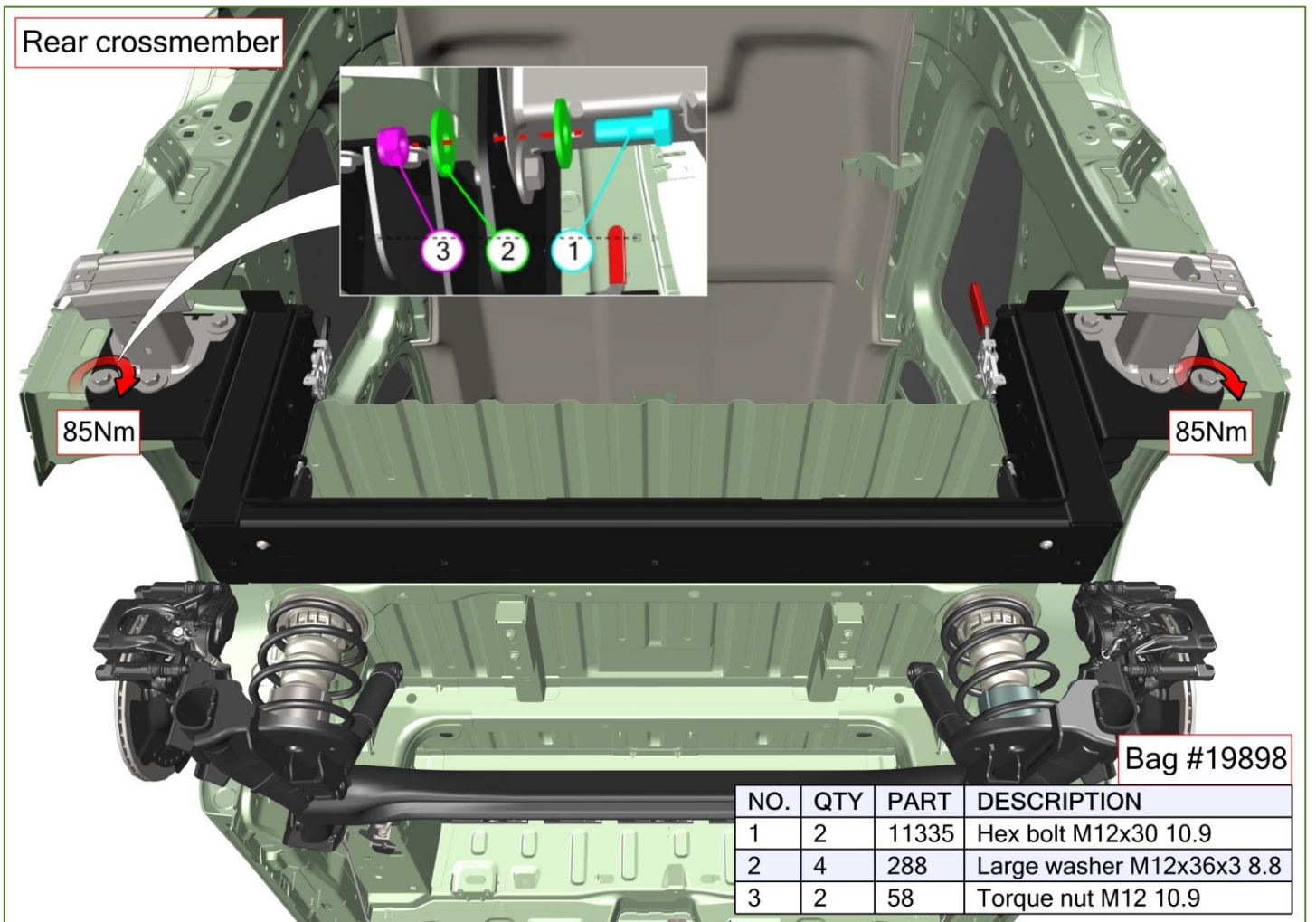

NO.	QTY	PART	DESCRIPTION
1	2	11335	Hex bolt M12x30 10.9
2	4	288	Large washer M12x36x3 8.8
3	2	58	Torque nut M12 10.9



Main floor cut

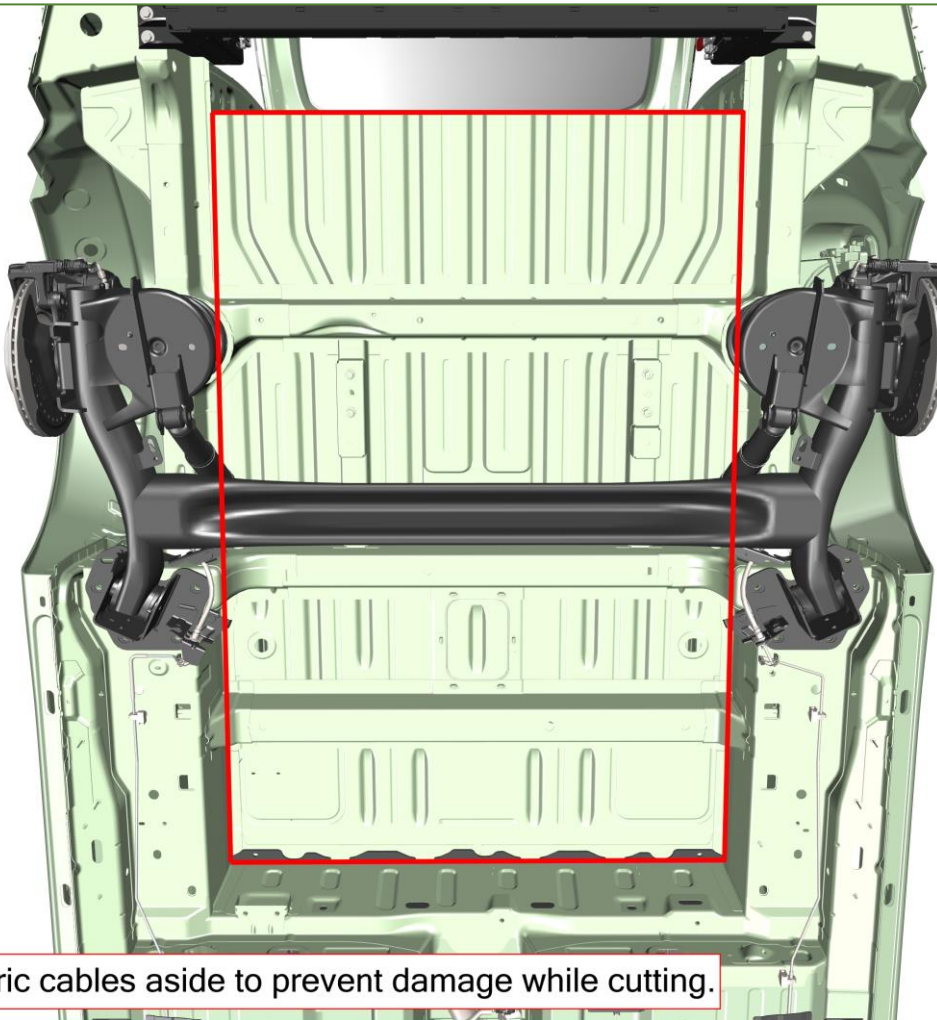

Move the electric cables aside to prevent damage while cutting.

Main floor cut

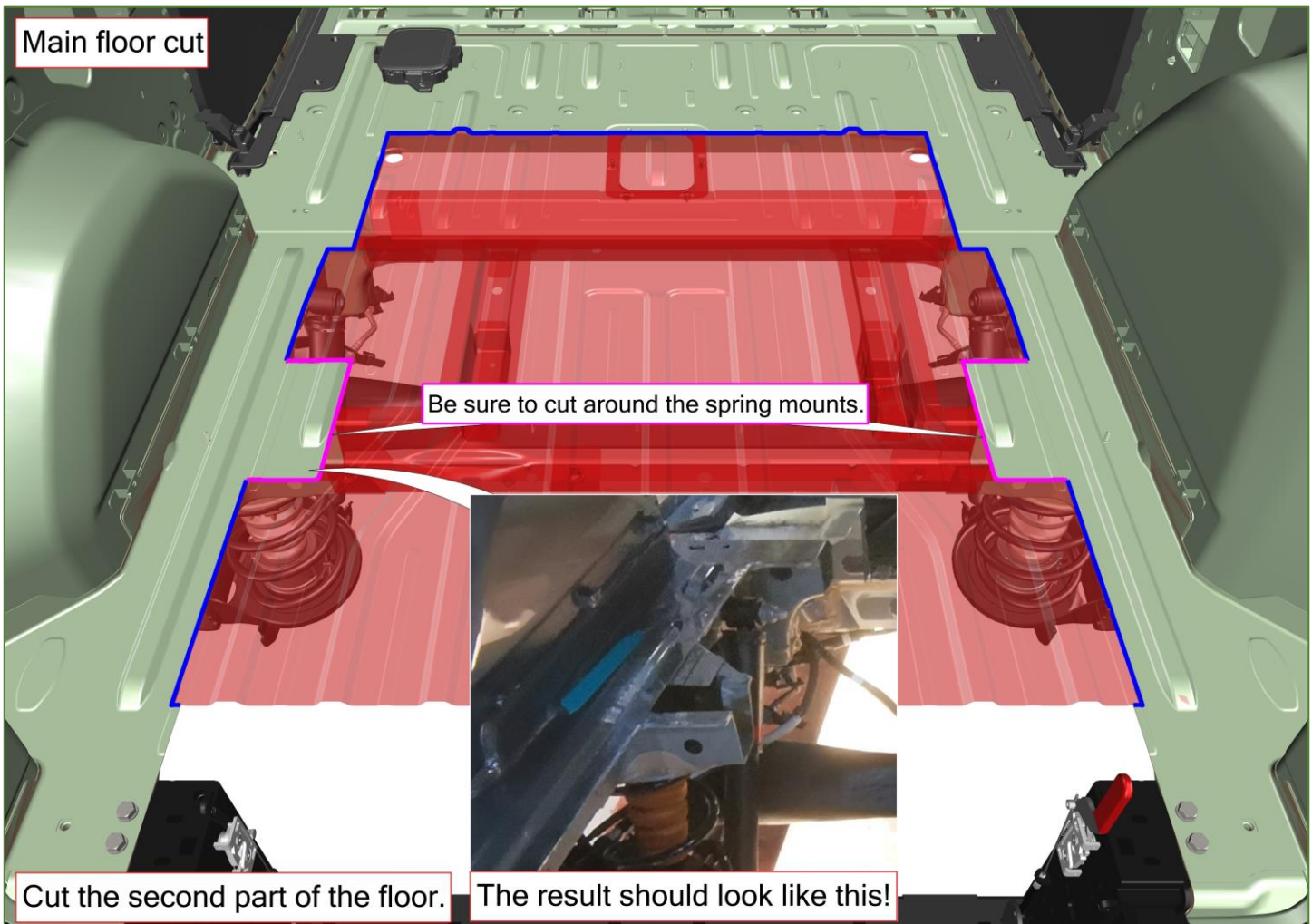

Be sure to cut around the spring mounts.

Cut the second part of the floor.

The result should look like this!

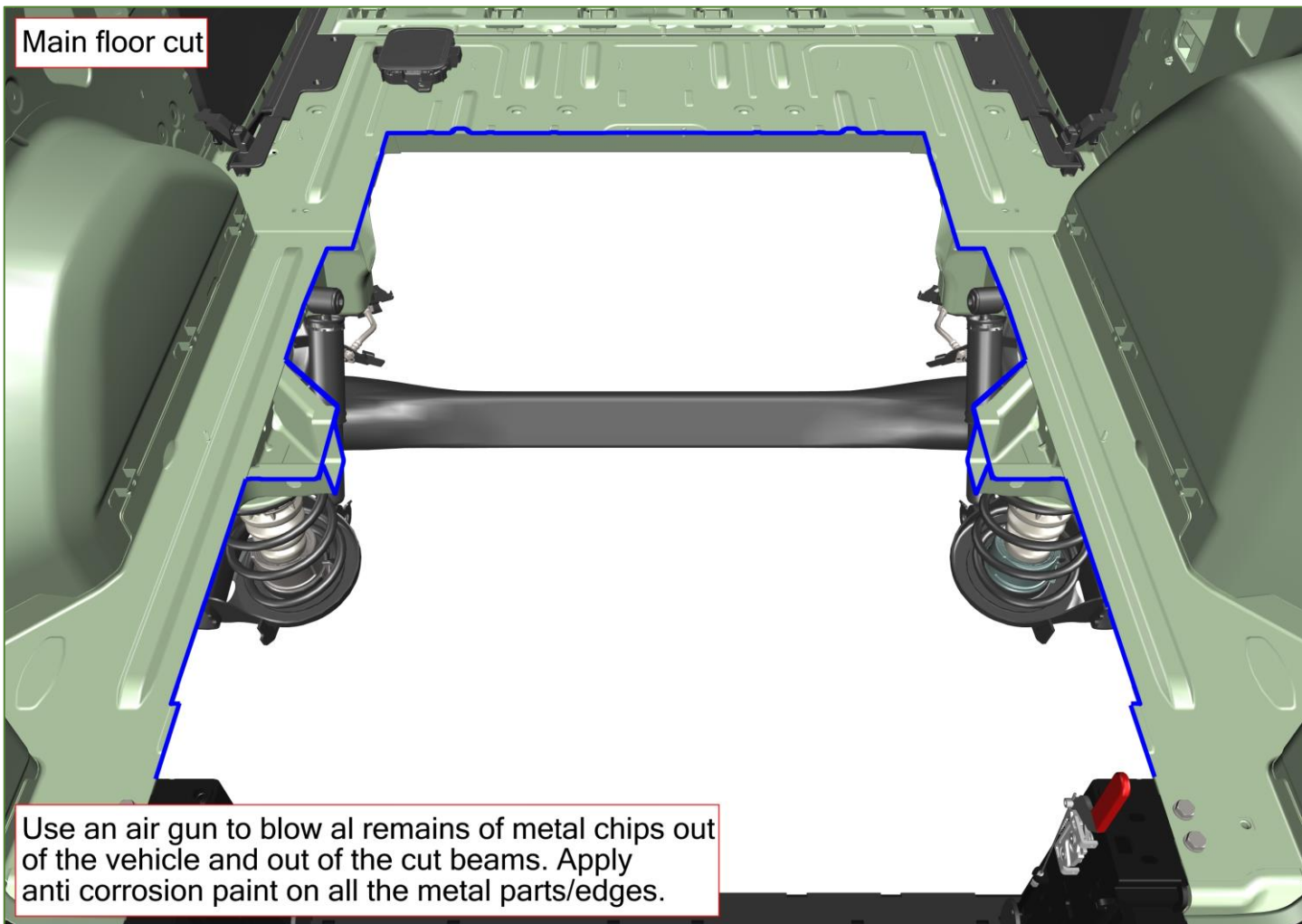
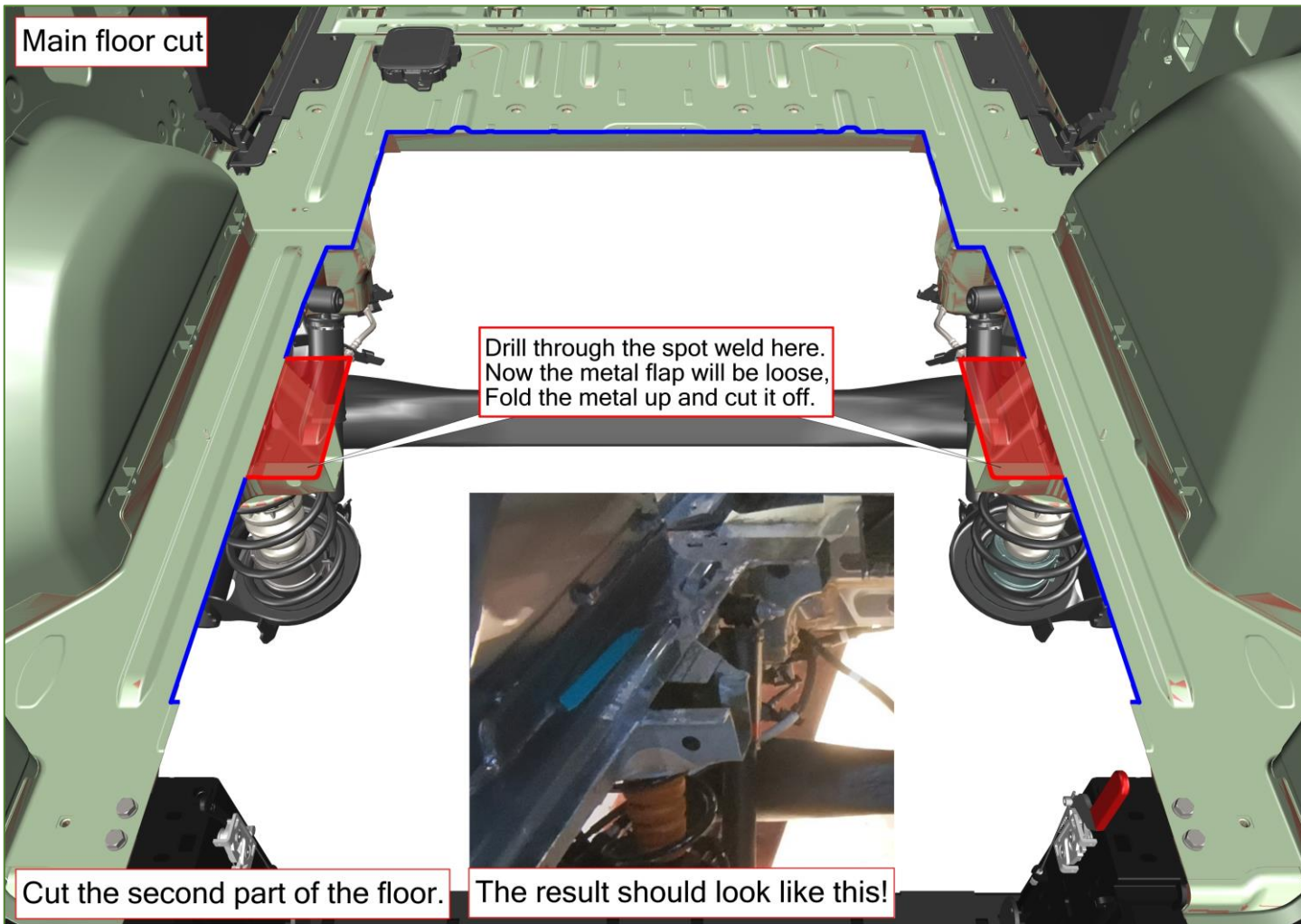



Suspension modification

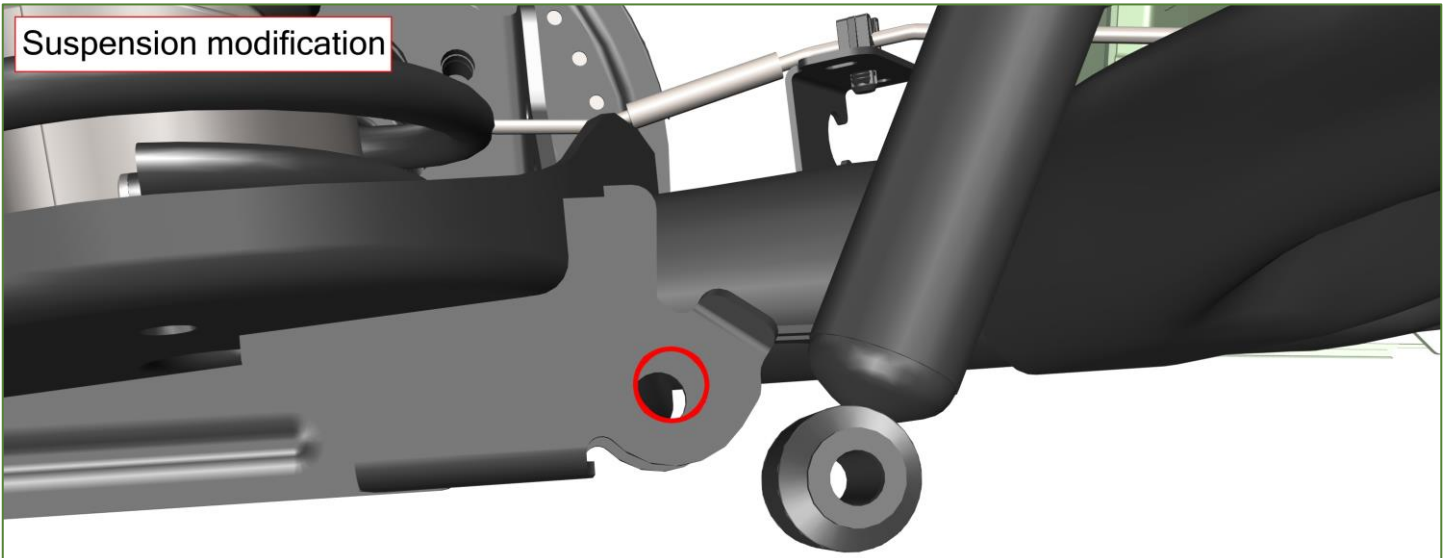

Dismount the lower shock absorber point.

Suspension modification

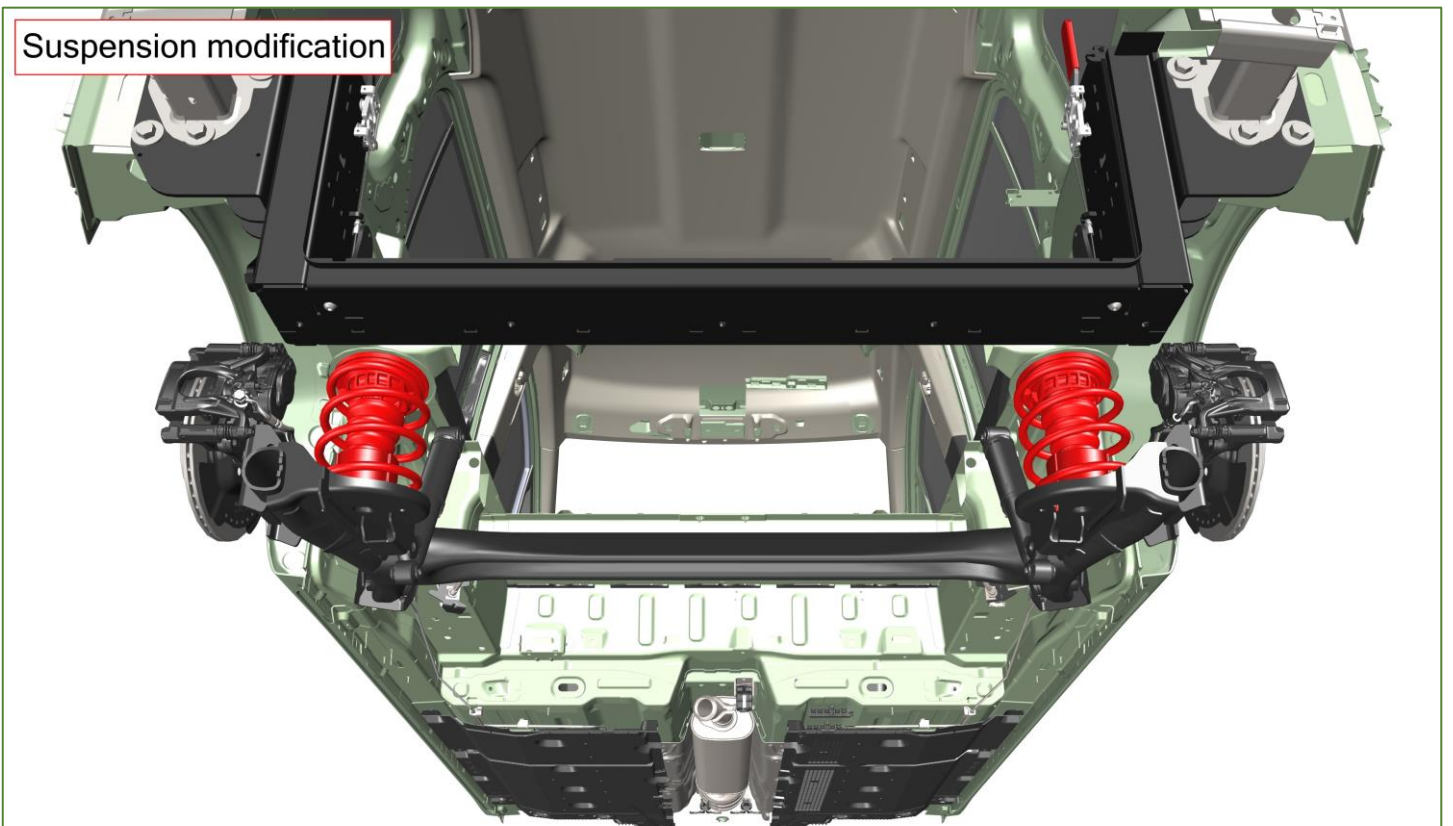

Take out the springs and bumpstops.

Suspension modification

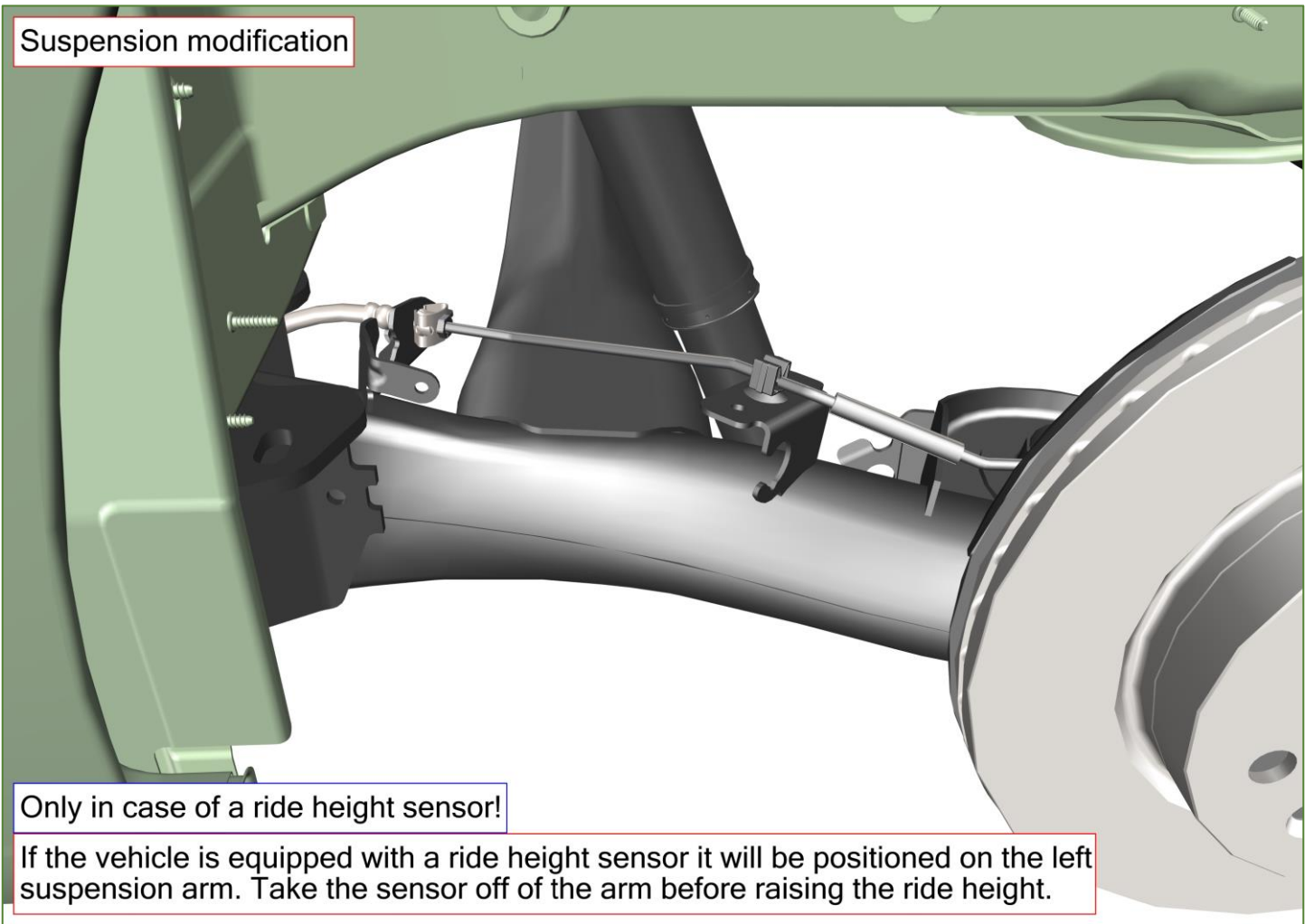

Only in case of a ride height sensor!

If the vehicle is equipped with a ride height sensor it will be positioned on the left suspension arm. Take the sensor off of the arm before raising the ride height.

Suspension modification

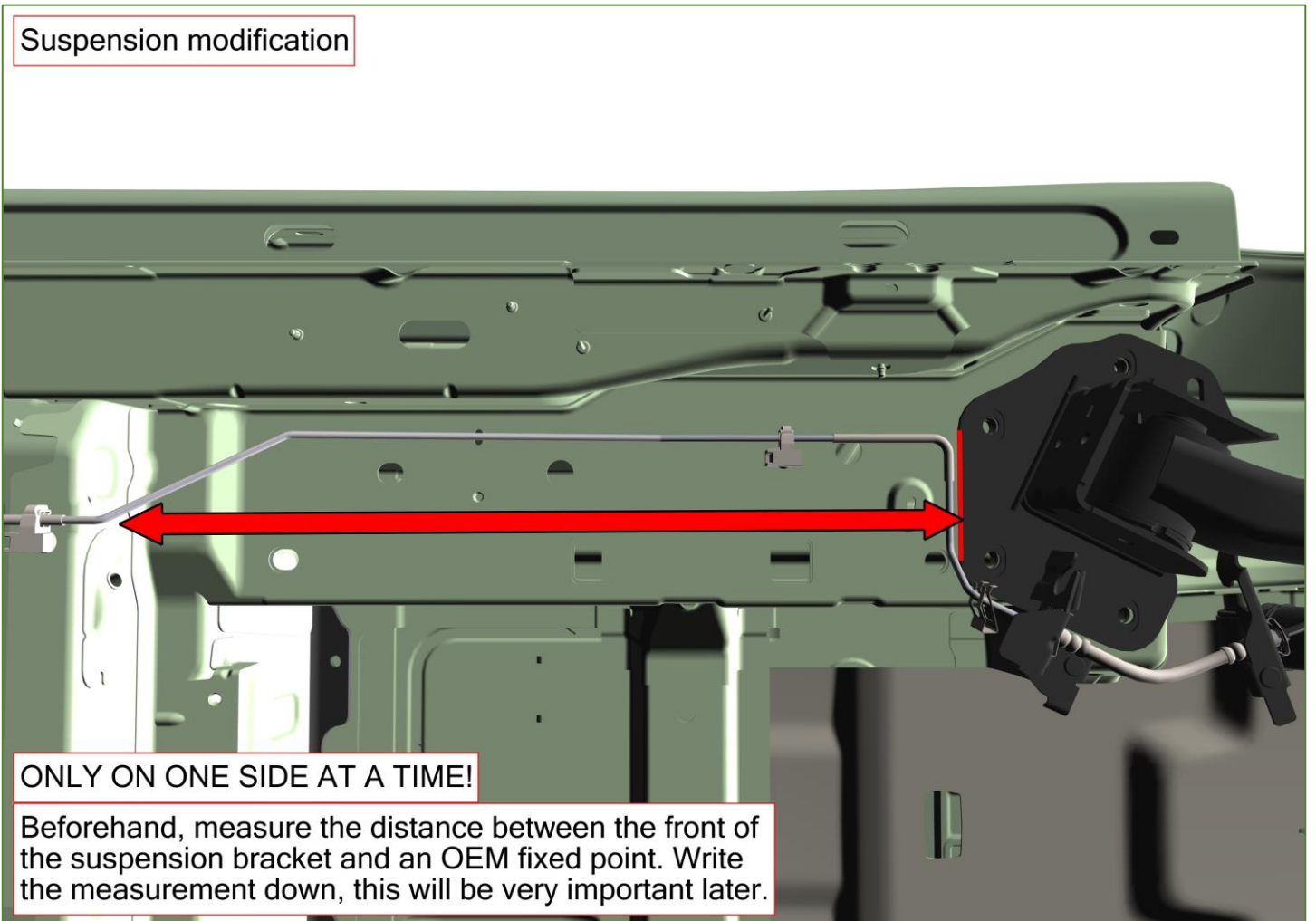

**ONLY ON ONE SIDE AT A TIME!**

Beforehand, measure the distance between the front of the suspension bracket and an OEM fixed point. Write the measurement down, this will be very important later.

Suspension modification

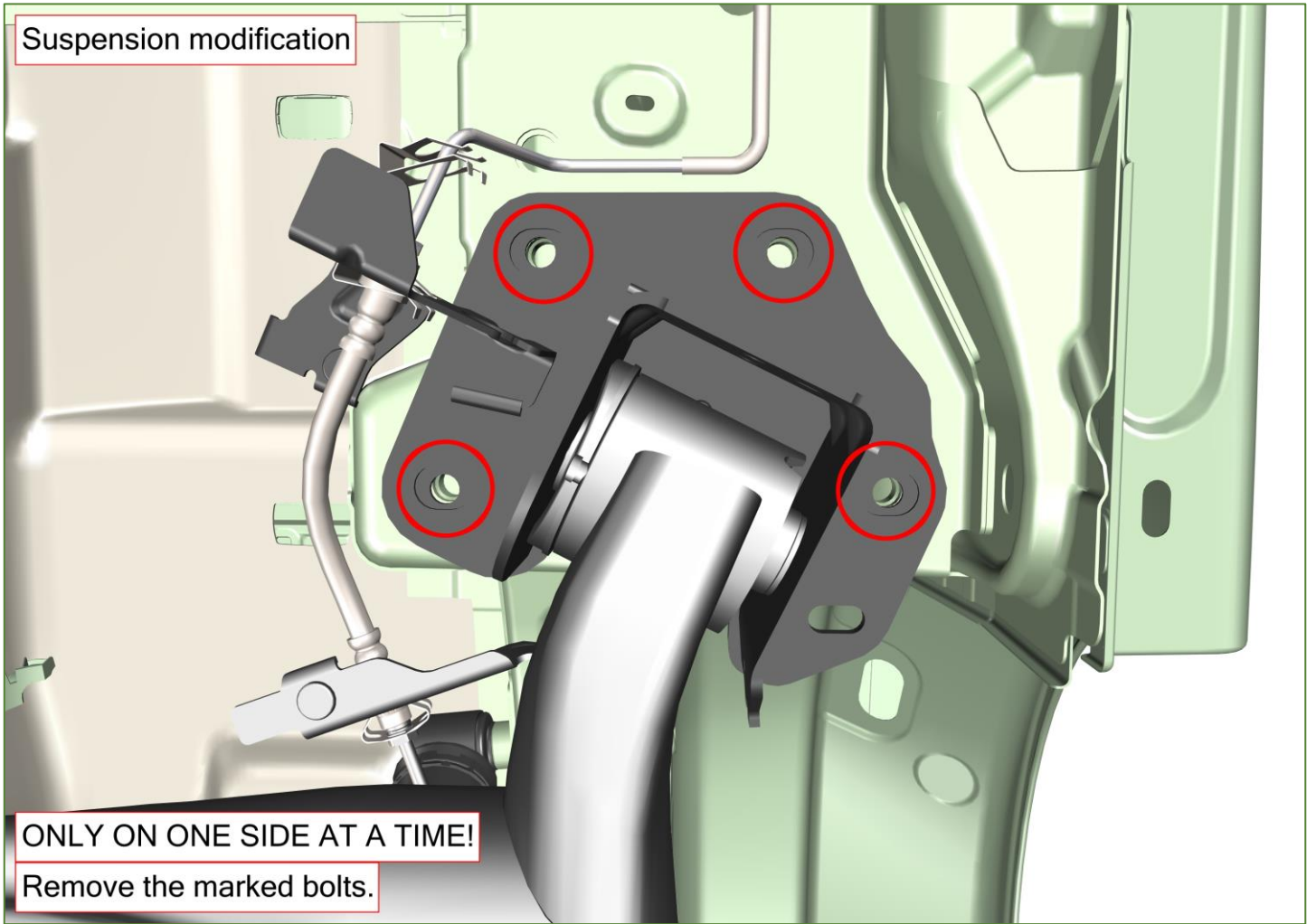

ONLY ON ONE SIDE AT A TIME!

Remove the marked bolts.

Suspension modification

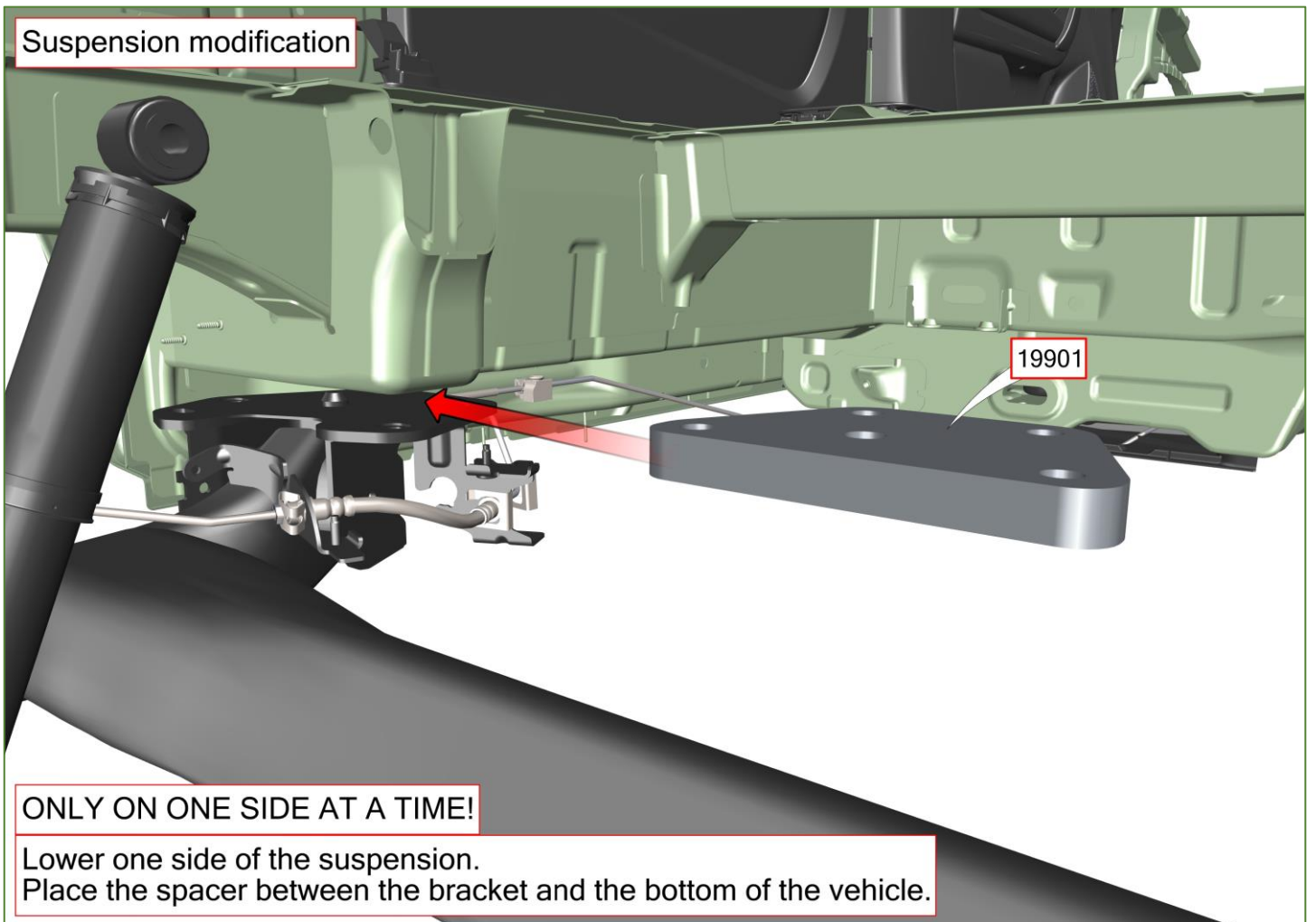

ONLY ON ONE SIDE AT A TIME!

Lower one side of the suspension.  
Place the spacer between the bracket and the bottom of the vehicle.



Suspension modification

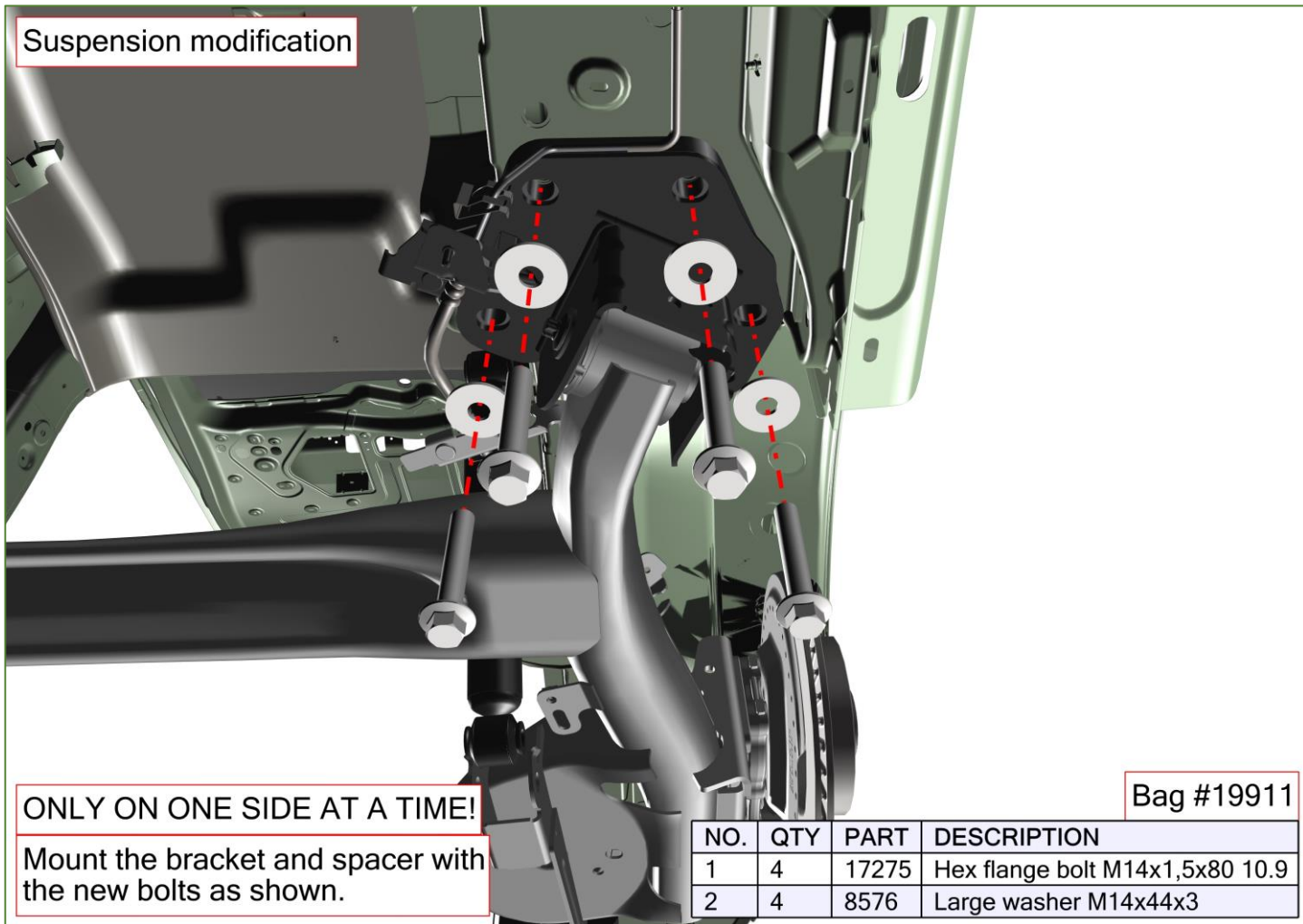

**ONLY ON ONE SIDE AT A TIME!**

Mount the bracket and spacer with the new bolts as shown.

Bag #19911

NO.	QTY	PART	DESCRIPTION
1	4	17275	Hex flange bolt M14x1,5x80 10.9
2	4	8576	Large washer M14x44x3

Suspension modification

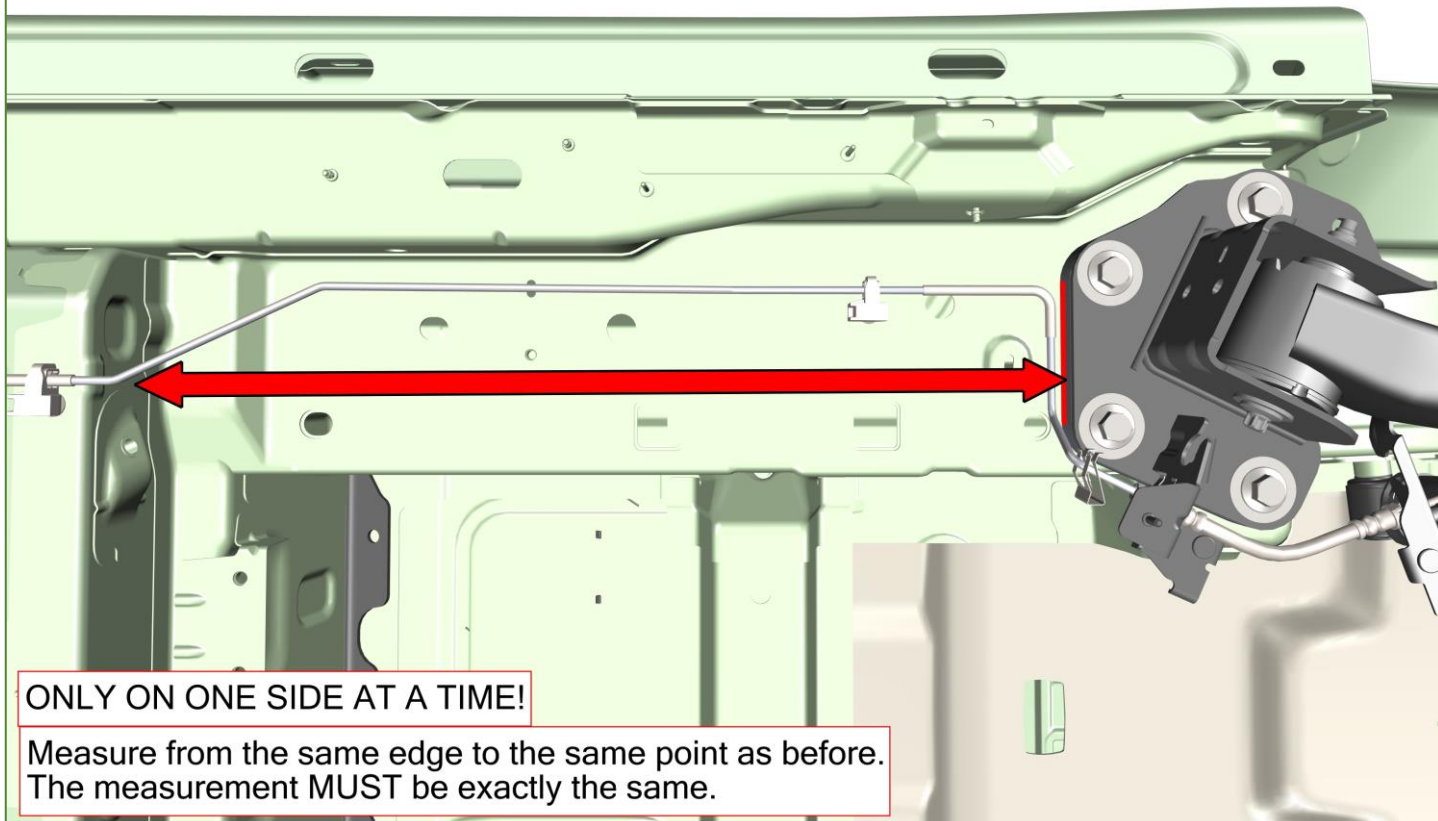

**ONLY ON ONE SIDE AT A TIME!**

Measure from the same edge to the same point as before. The measurement **MUST** be exactly the same.

Suspension modification

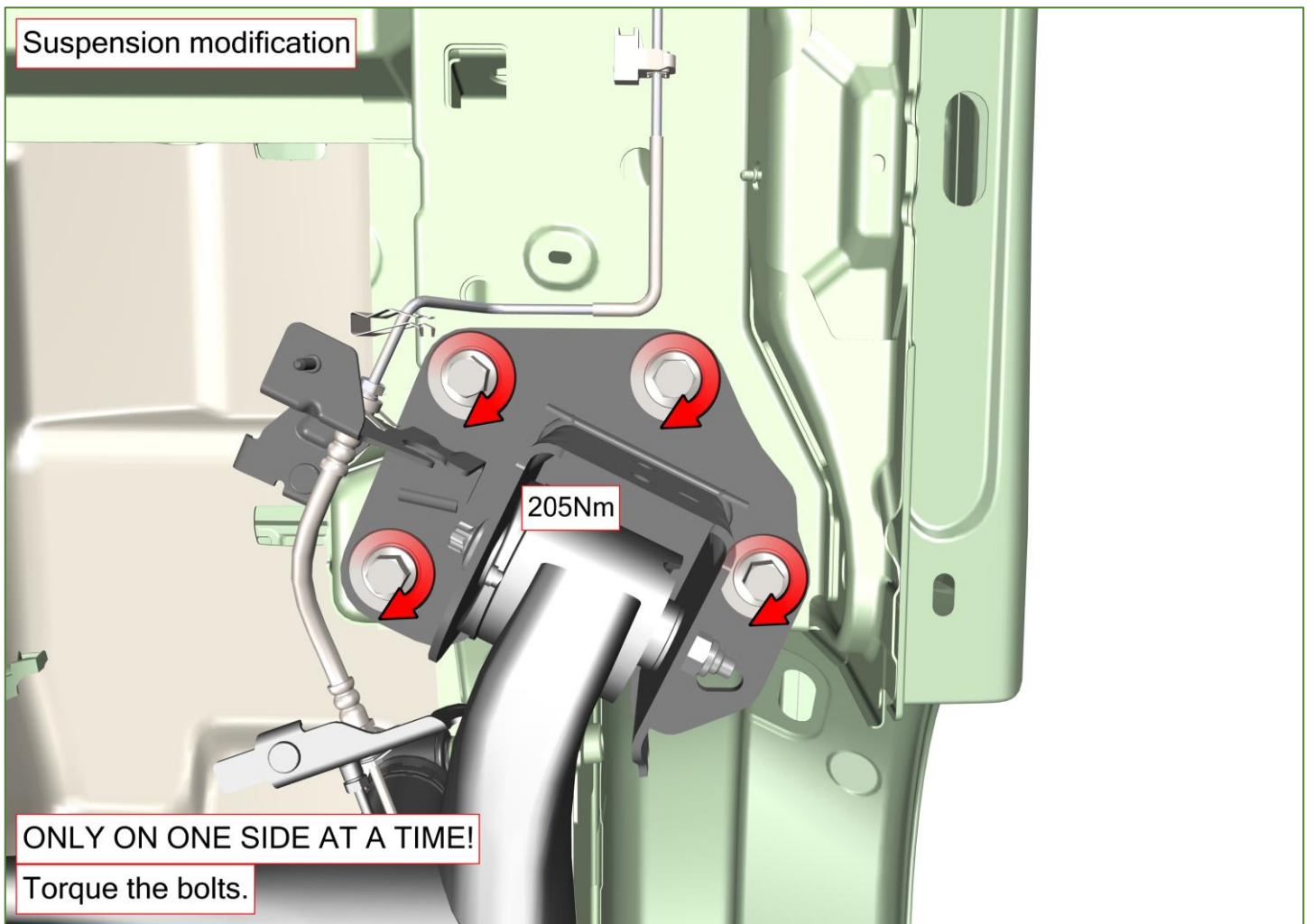

ONLY ON ONE SIDE AT A TIME!

Torque the bolts.

Suspension modification

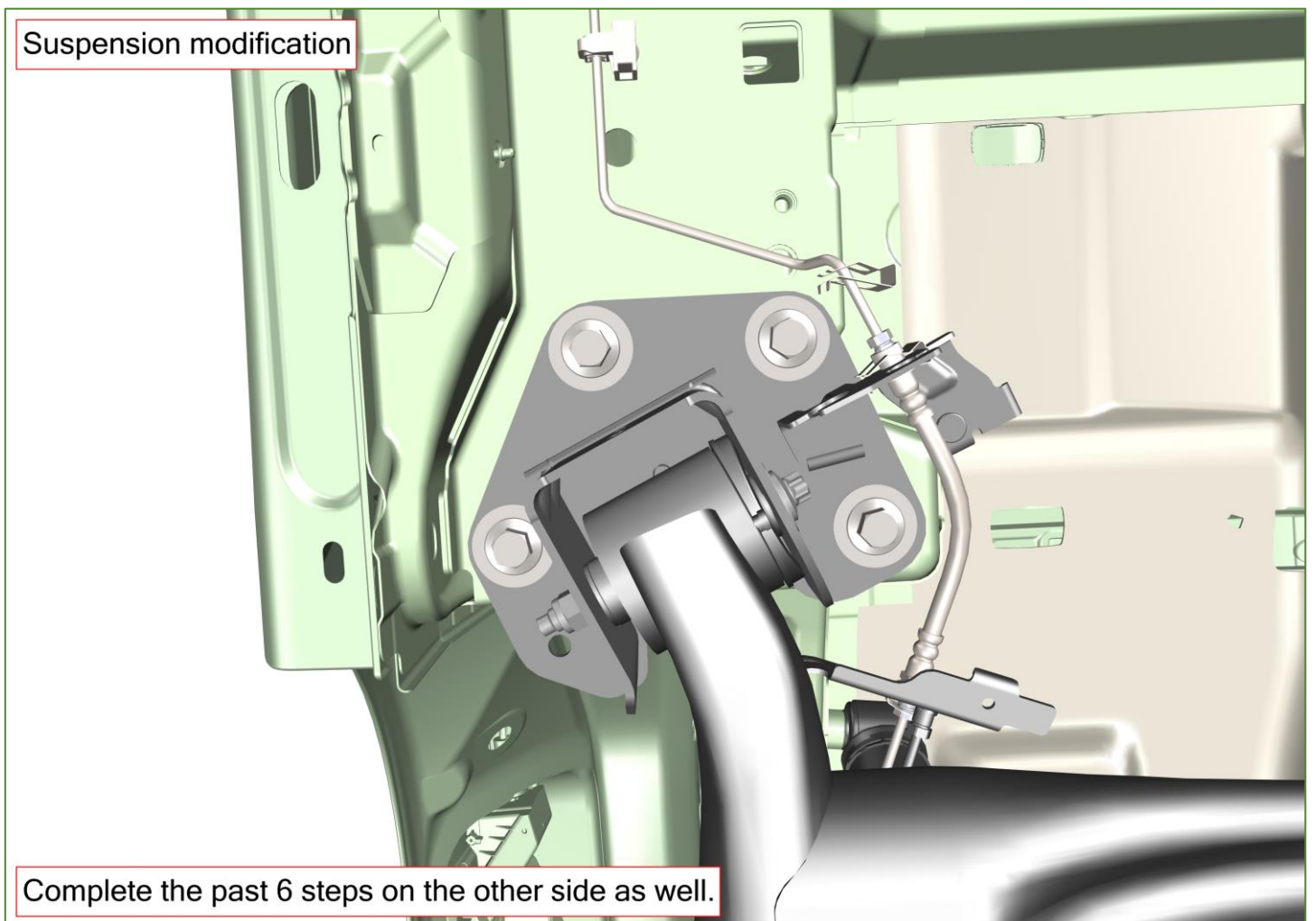

Complete the past 6 steps on the other side as well.



Suspension modification

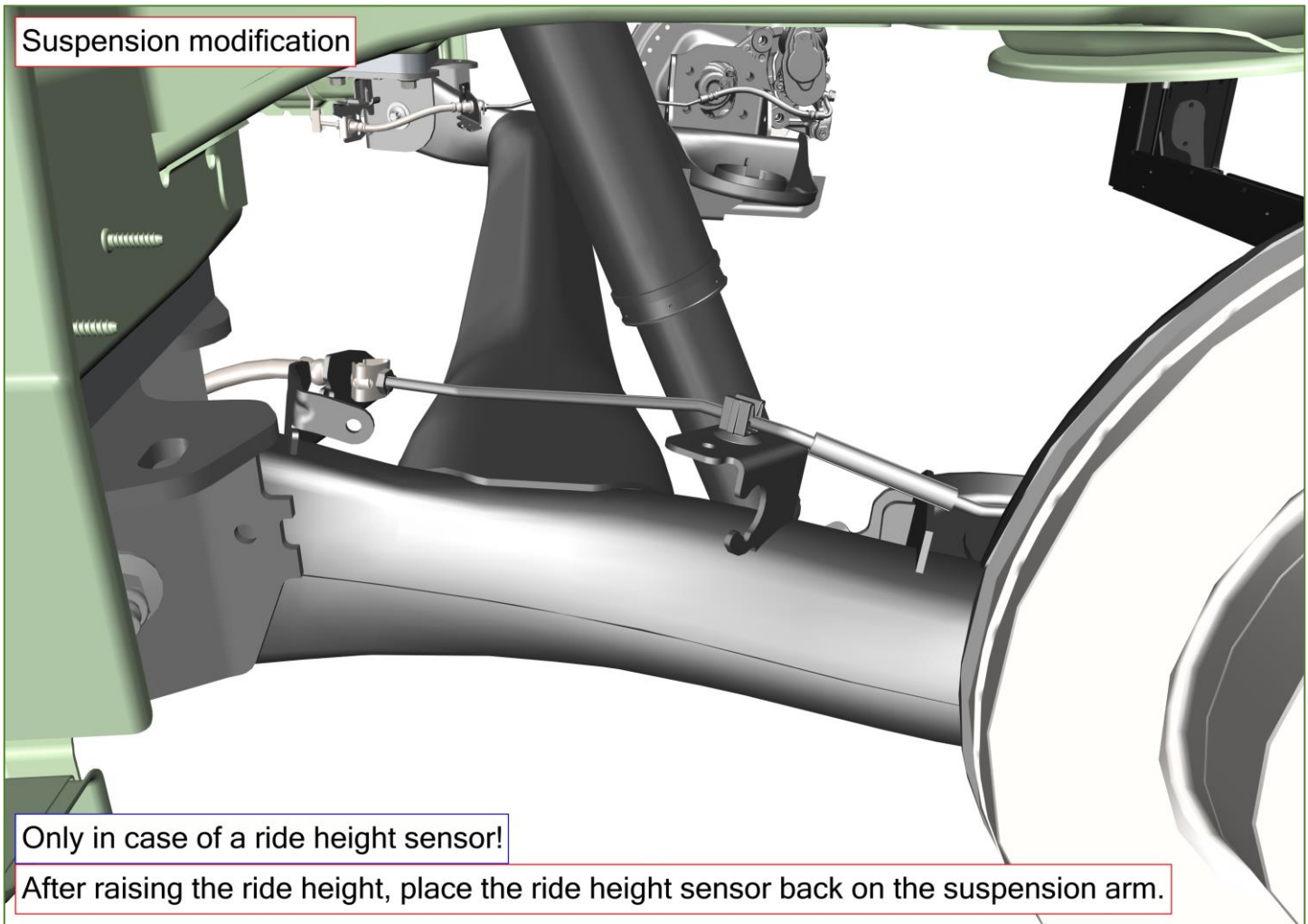

Only in case of a ride height sensor!

After raising the ride height, place the ride height sensor back on the suspension arm.

Suspension modification

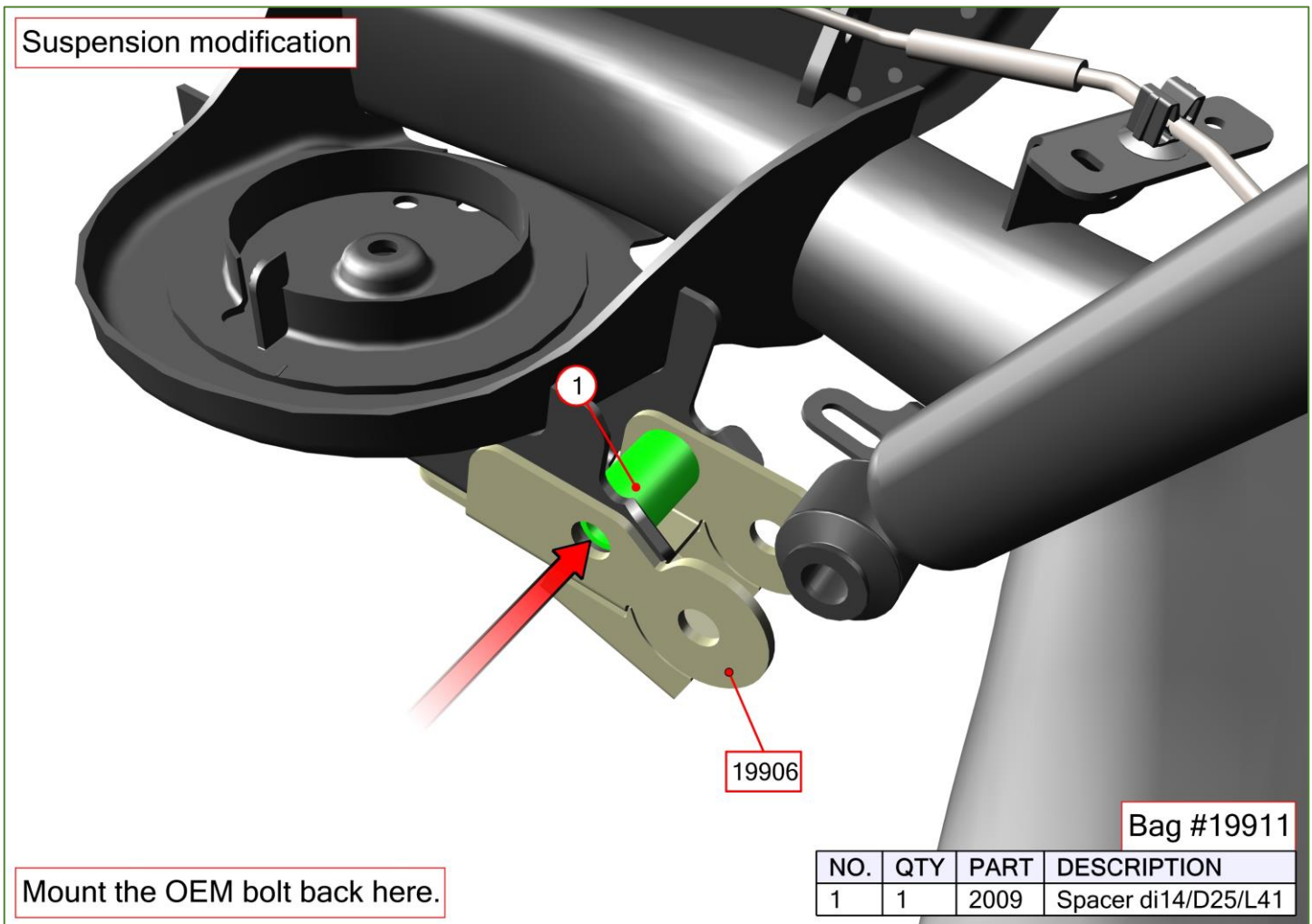

Mount the OEM bolt back here.

Bag #19911

NO.	QTY	PART	DESCRIPTION
1	1	2009	Spacer di14/D25/L41

Suspension modification

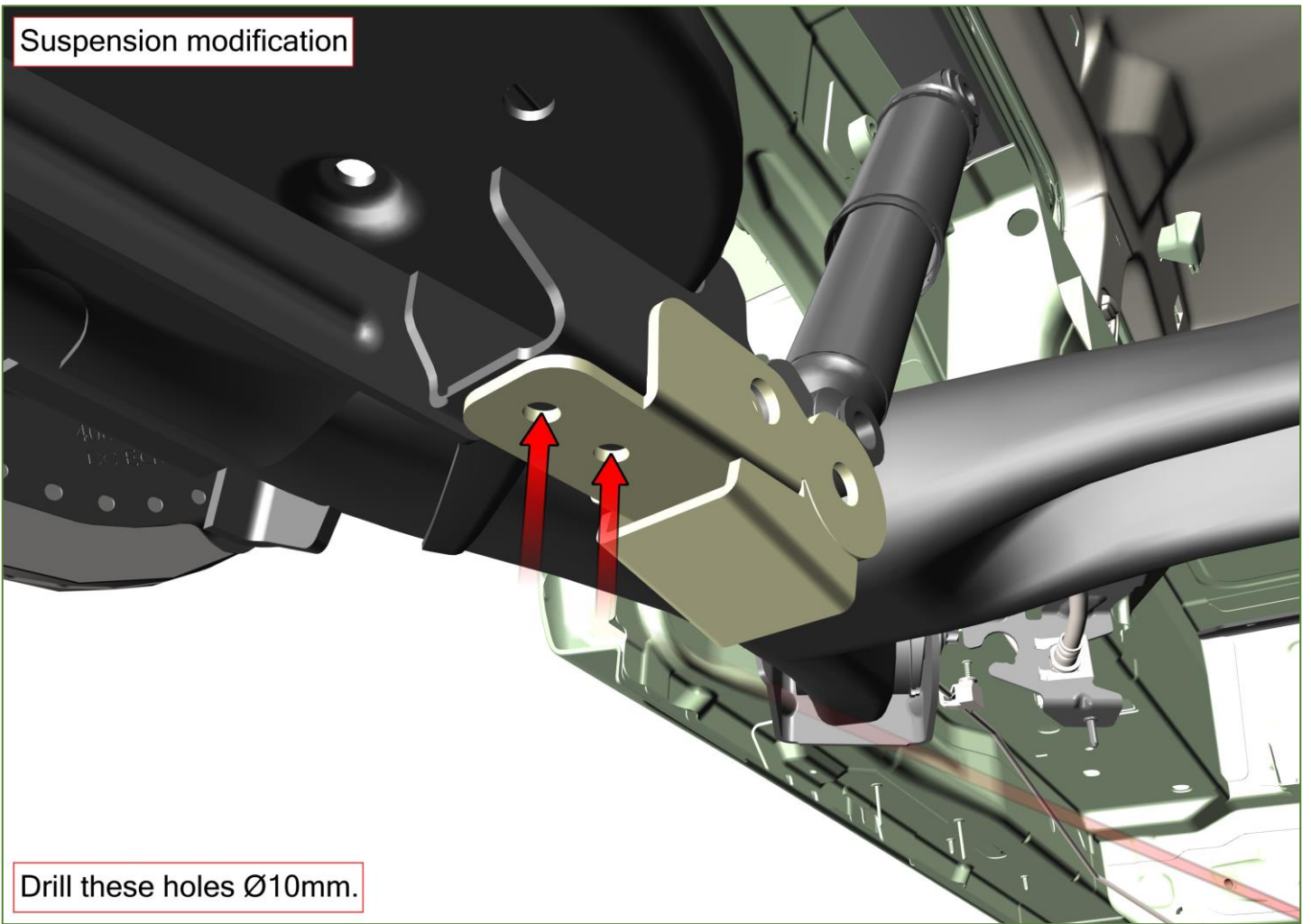

Drill these holes Ø10mm.

Suspension modification

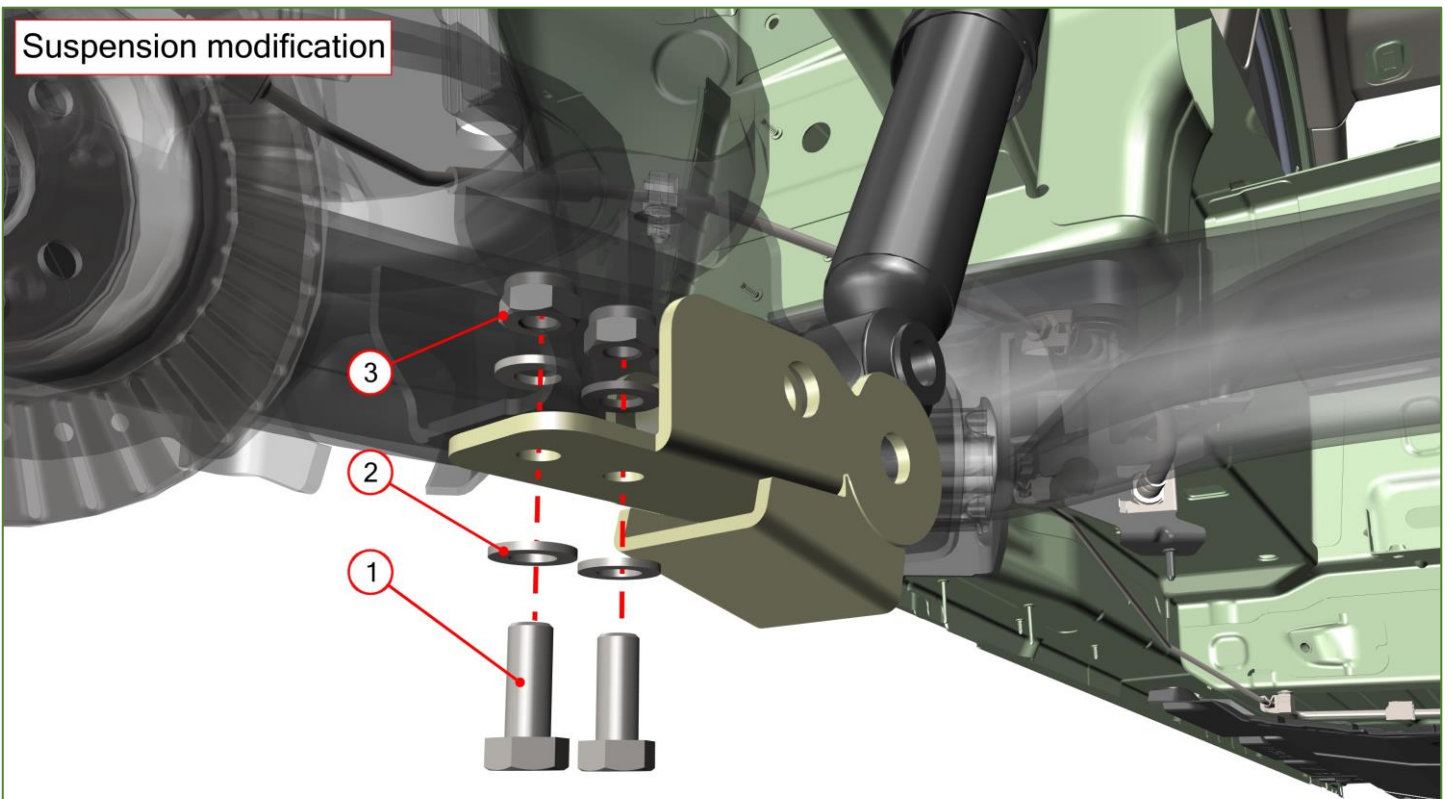

Bag #19911

Mount the bottom of the bracket as shown.

NO.	QTY	PART	DESCRIPTION
1	2	9113	Hex bolt M10x25 8.8
2	4	173	Washer M10 8.8
3	2	63	Torque nut M10 8.8



Suspension modification

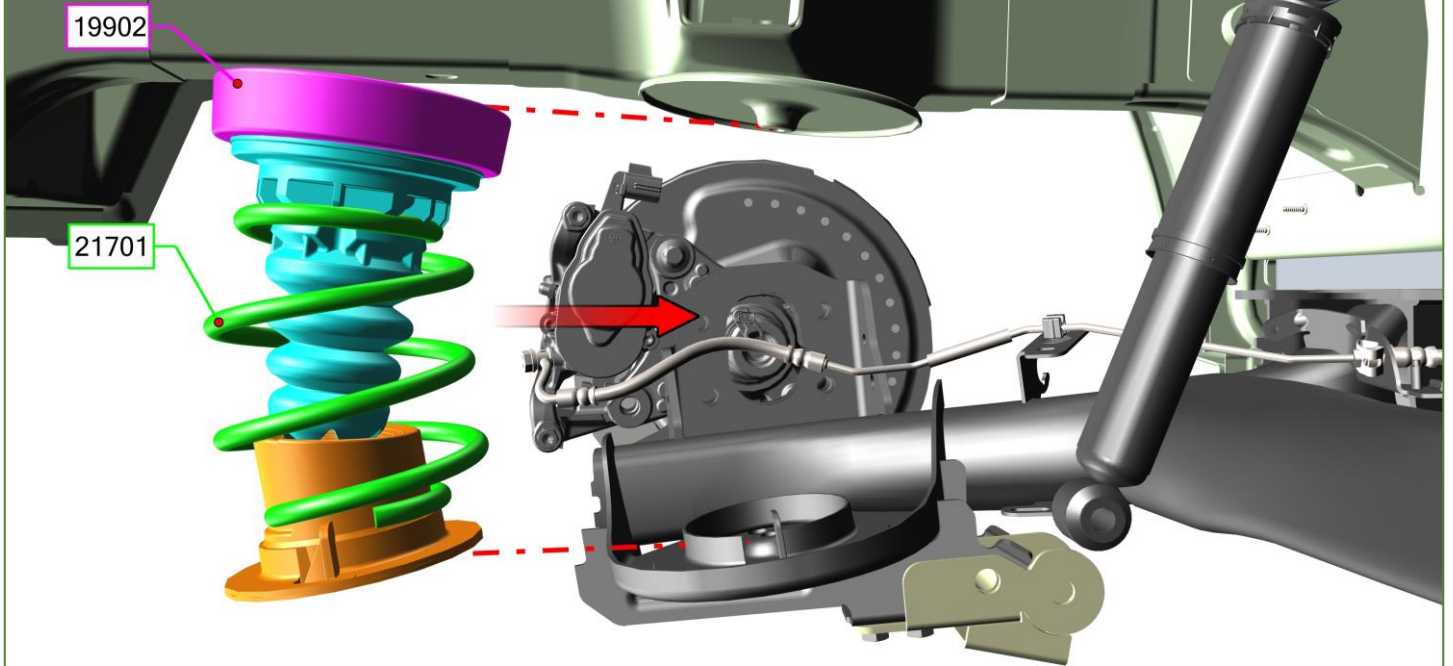

Place the bumpstops, spring and new spacer on the rear axle as shown.

Suspension modification

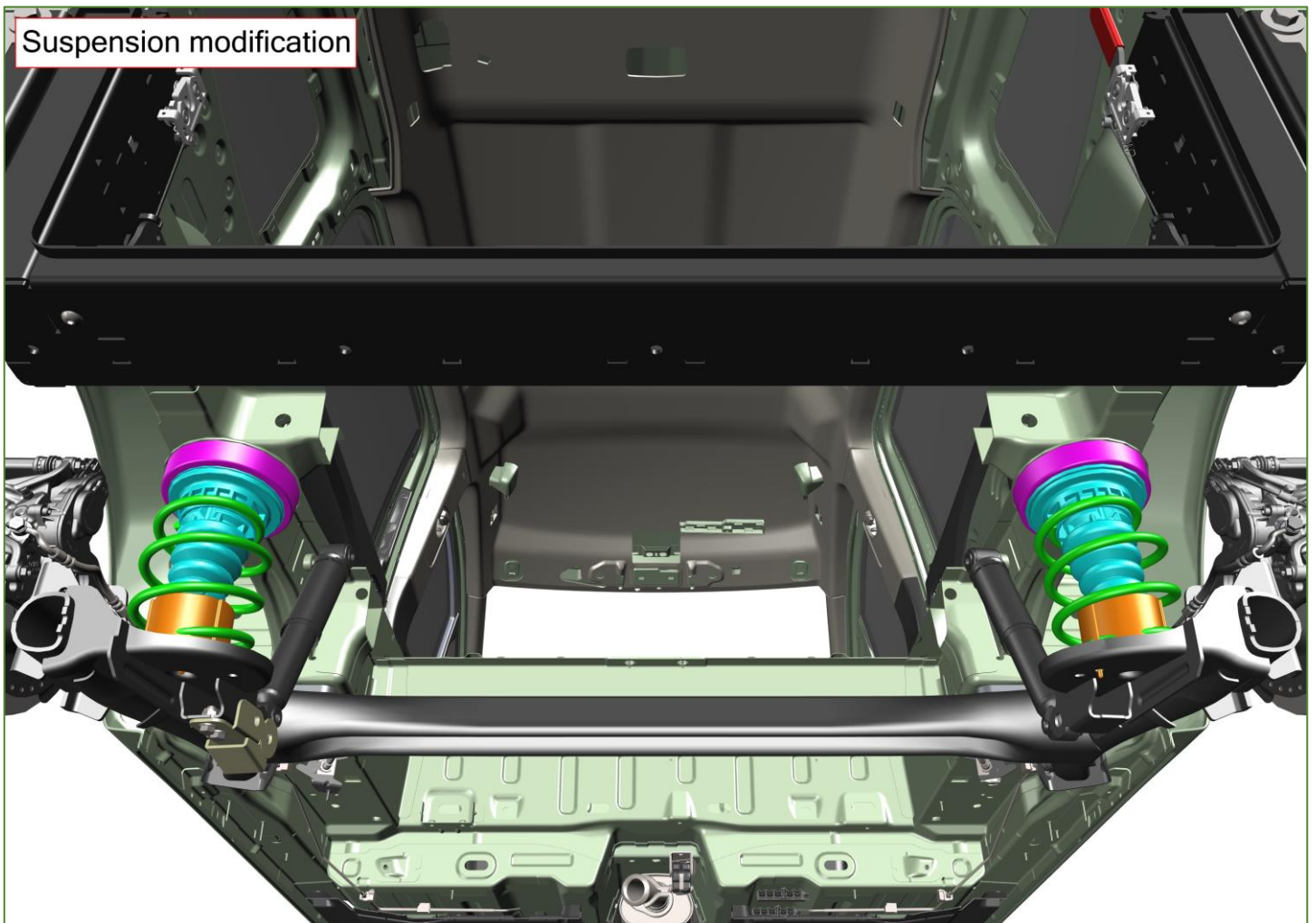



Suspension modification

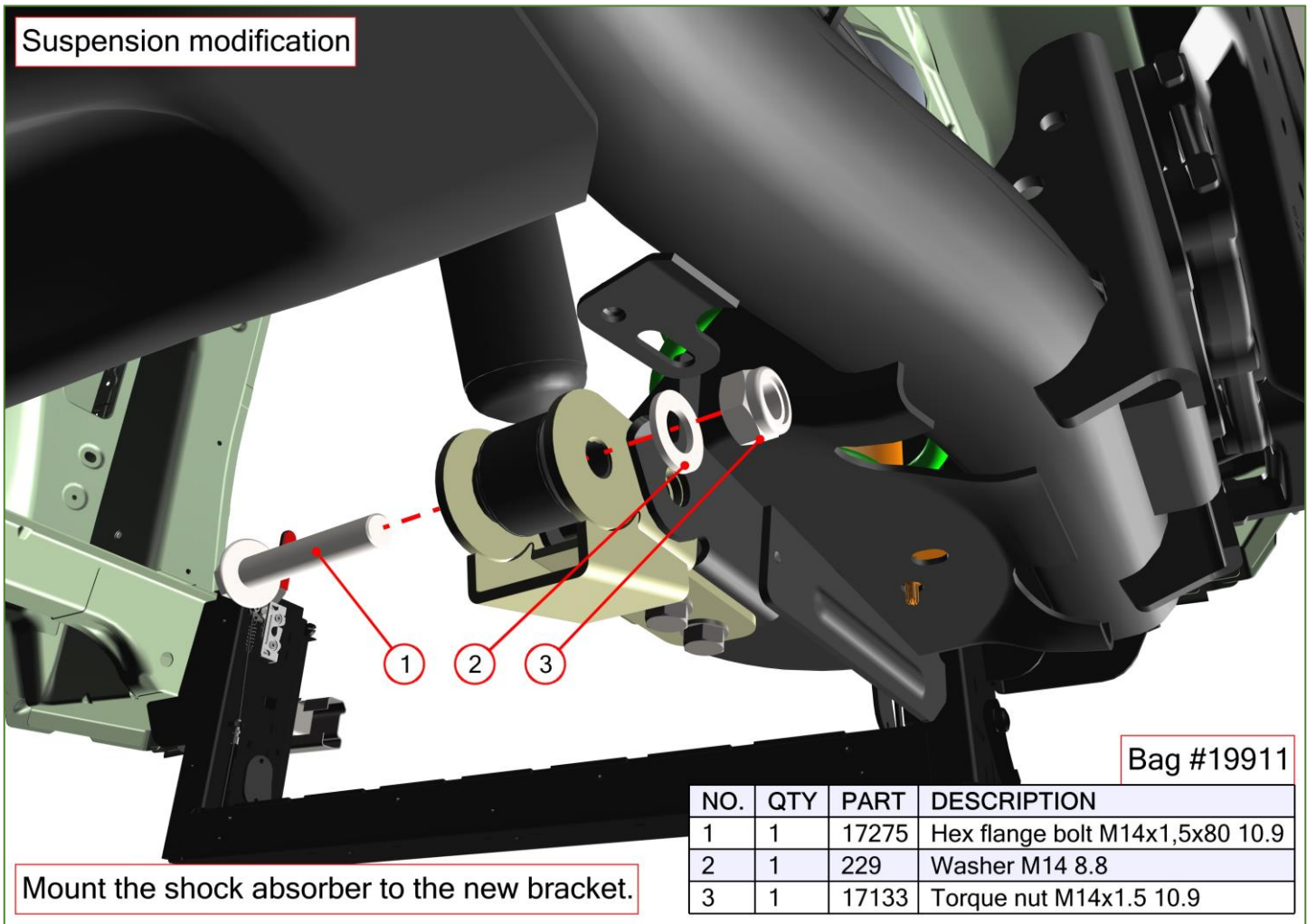

NO.	QTY	PART	DESCRIPTION
1	1	17275	Hex flange bolt M14x1,5x80 10.9
2	1	229	Washer M14 8.8
3	1	17133	Torque nut M14x1.5 10.9

Mount the shock absorber to the new bracket.

Suspension modification

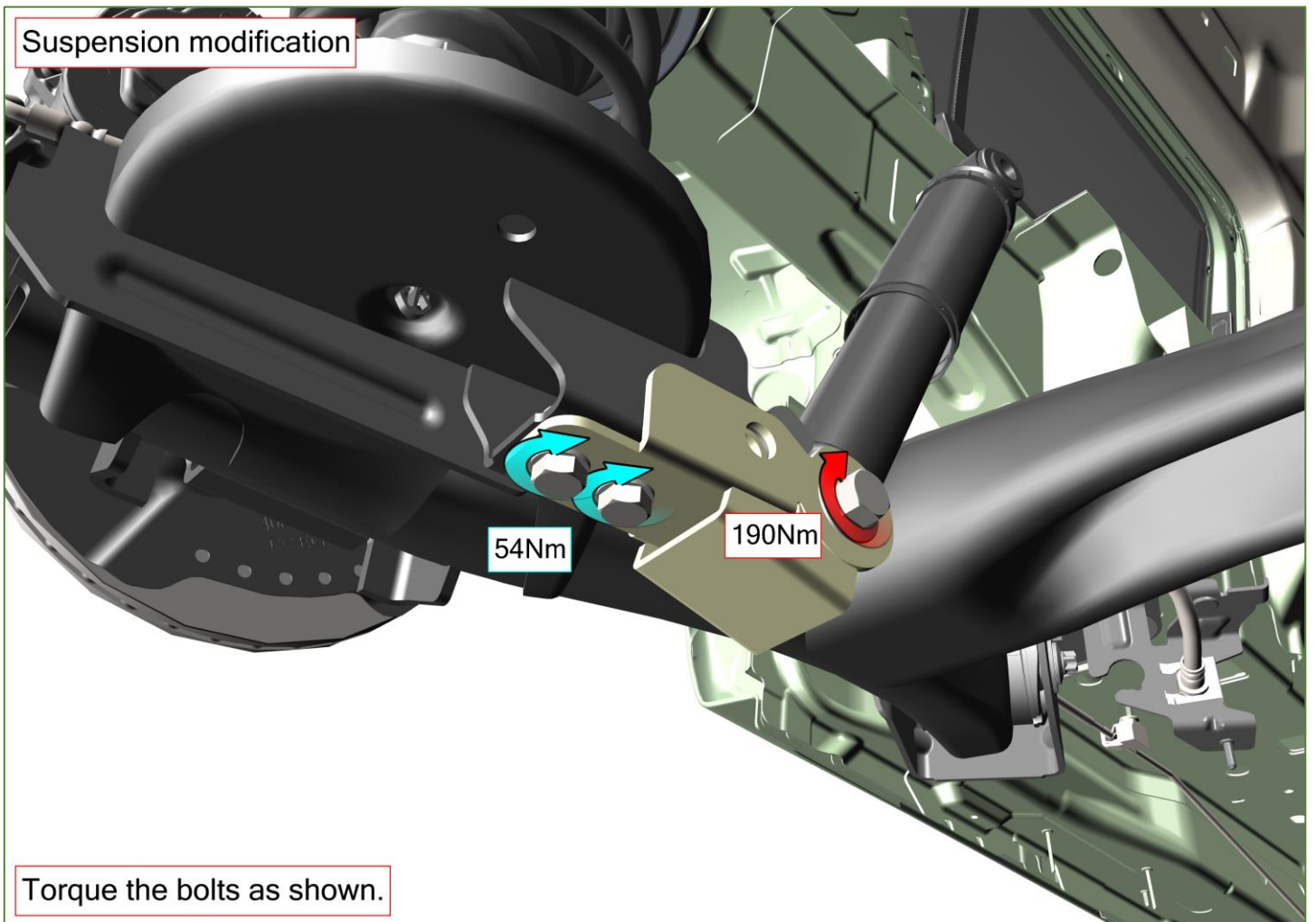

Torque the bolts as shown.

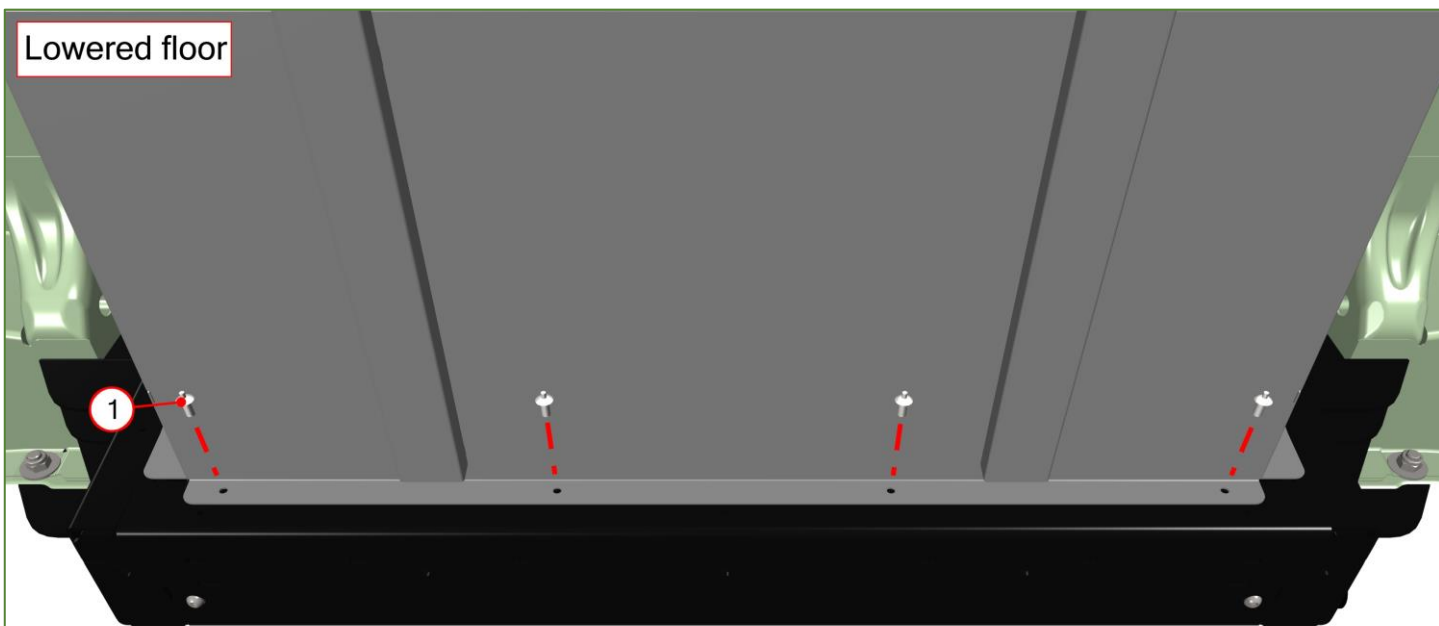
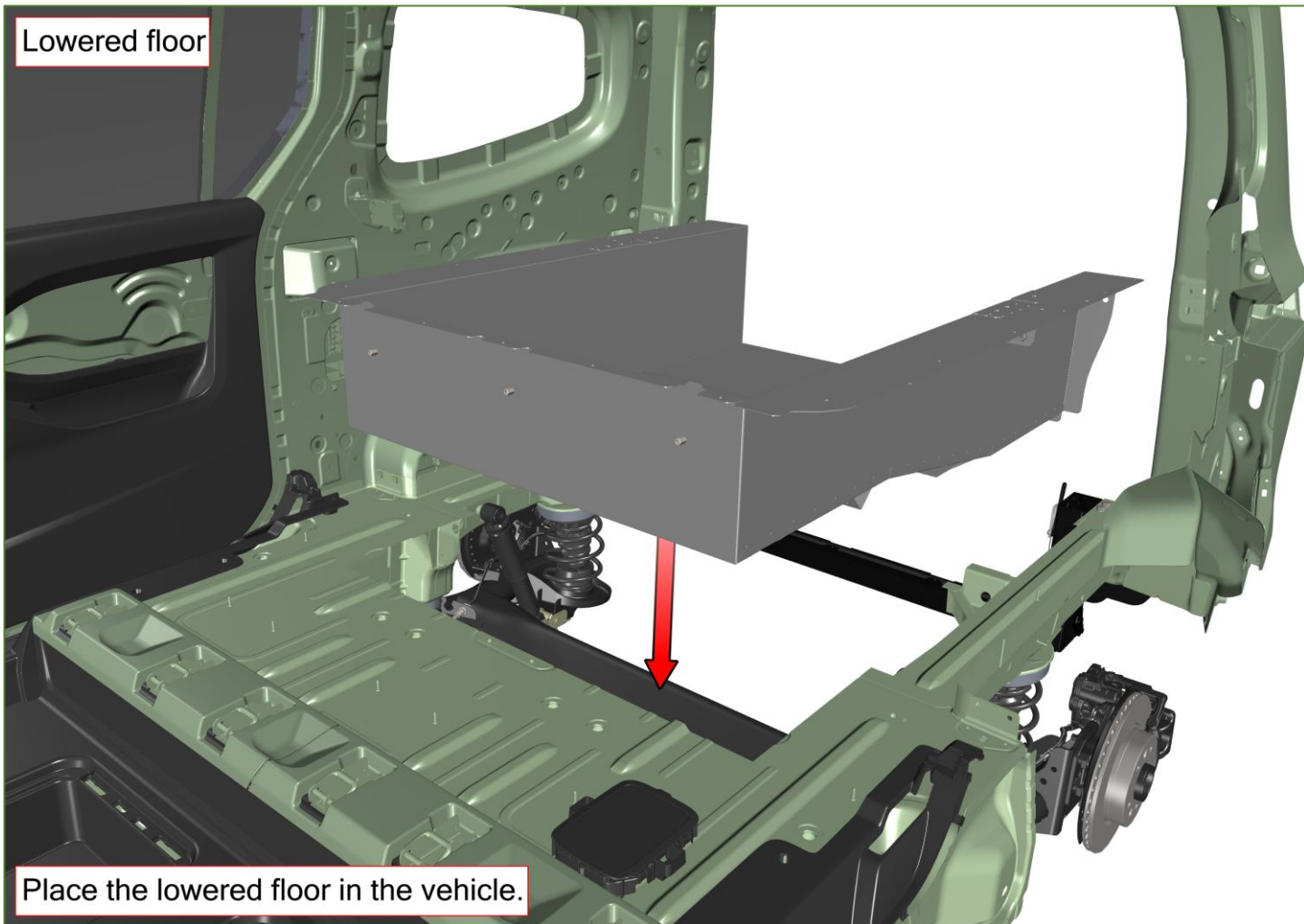

Bag #20573

Place the lowered floor in the vehicle.

NO.	QTY	PART	DESCRIPTION
1	4	7887	Magna-lock pop rivet 6,4x14 8.8

Lowered floor

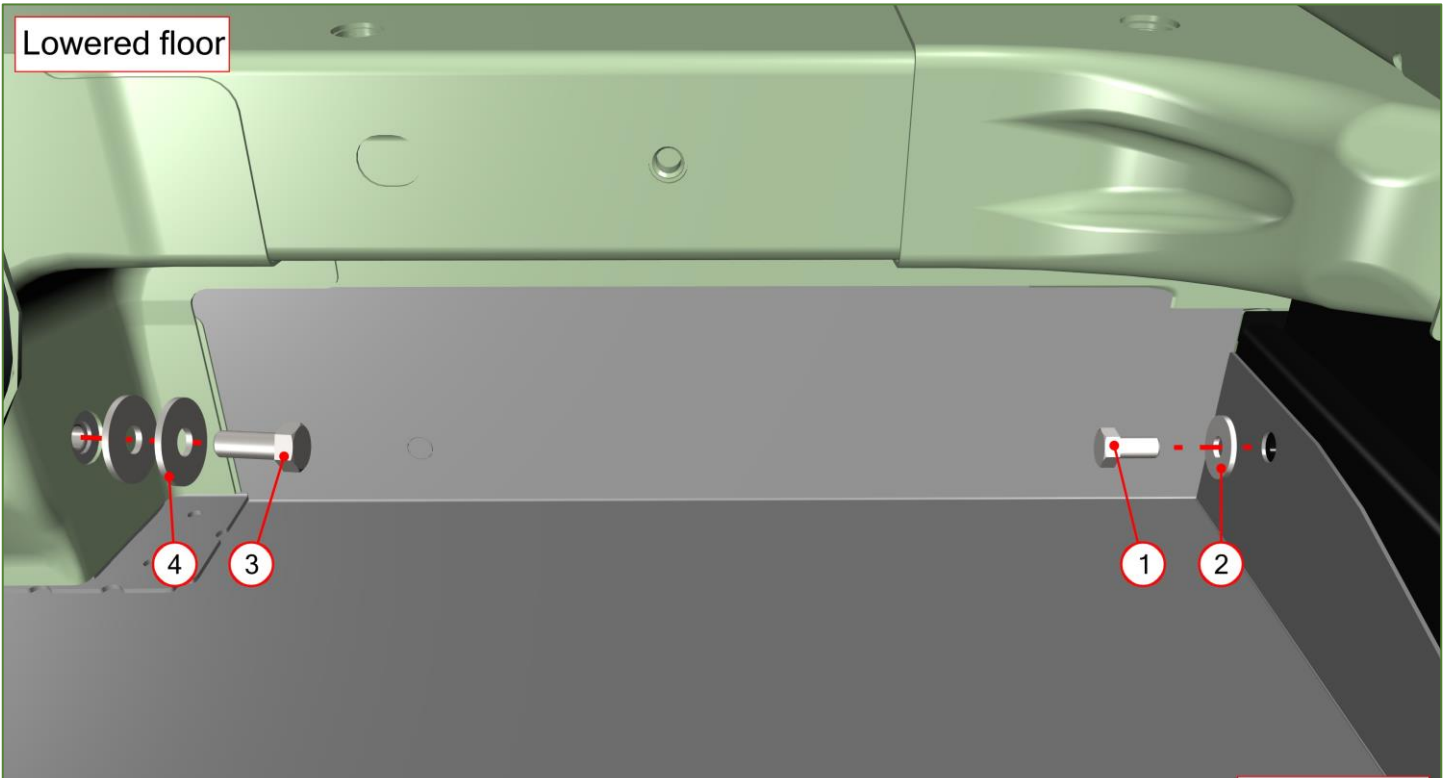

Bag #19898

NO.	QTY	PART	DESCRIPTION
1	1	205	Hex bolt M8x16 8.8
2	1	1246	Large washer M8 8.8
3	1	9113	Hex bolt M10x25 8.8
4	2	9112	Large washer M10x33x2.5 8.8

Mount hand tight, do not torque yet.

Lowered floor

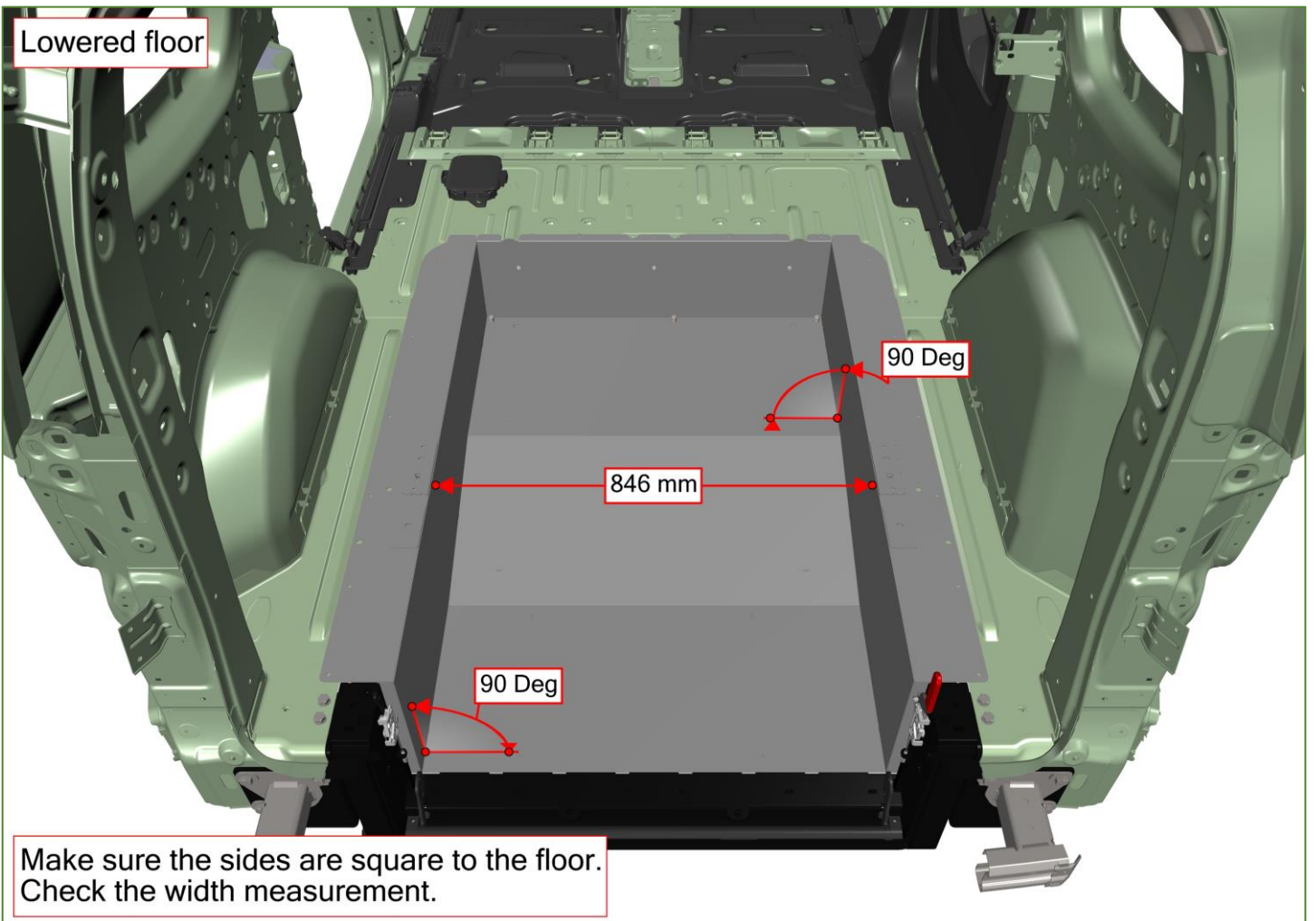

Make sure the sides are square to the floor. Check the width measurement.



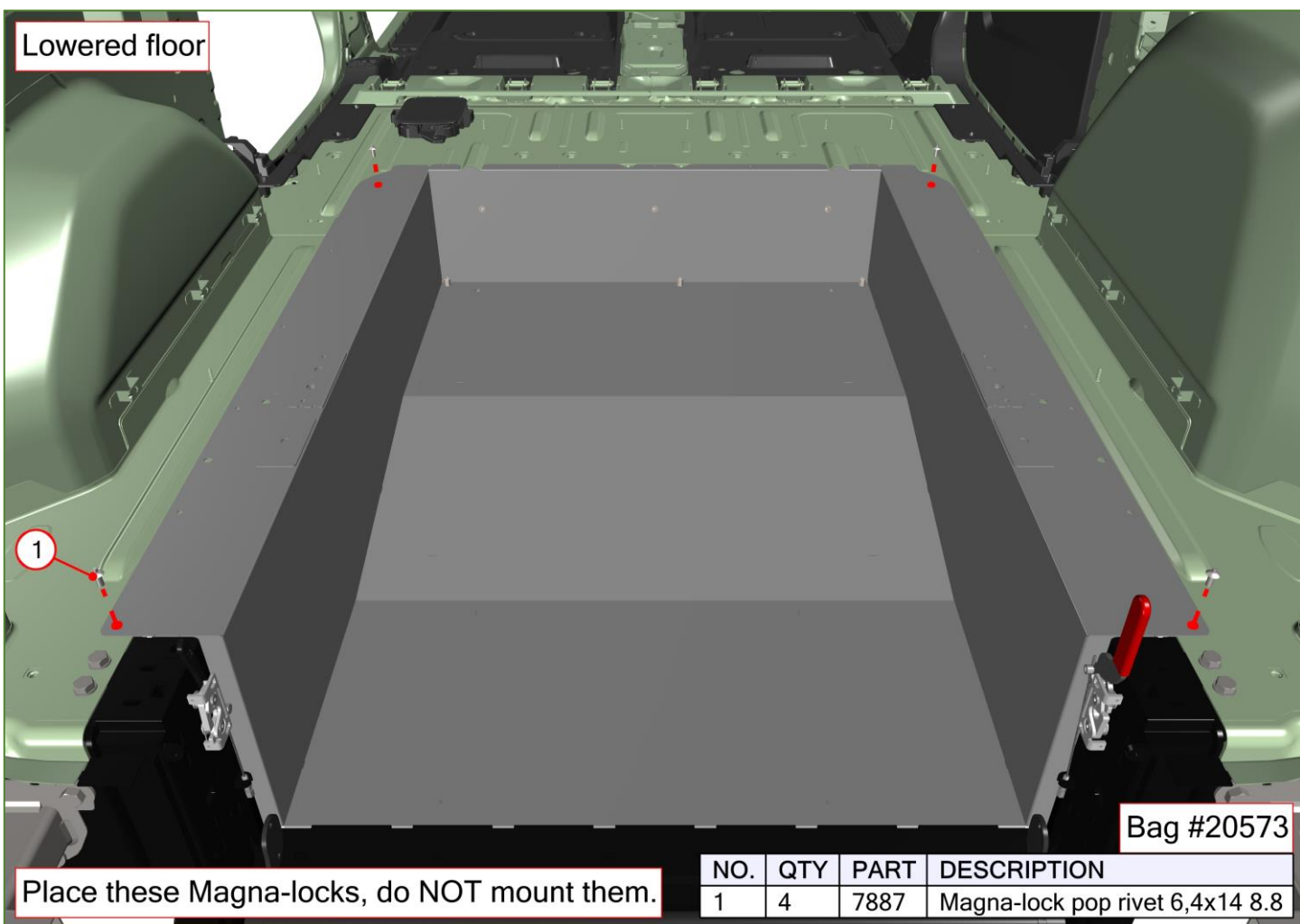
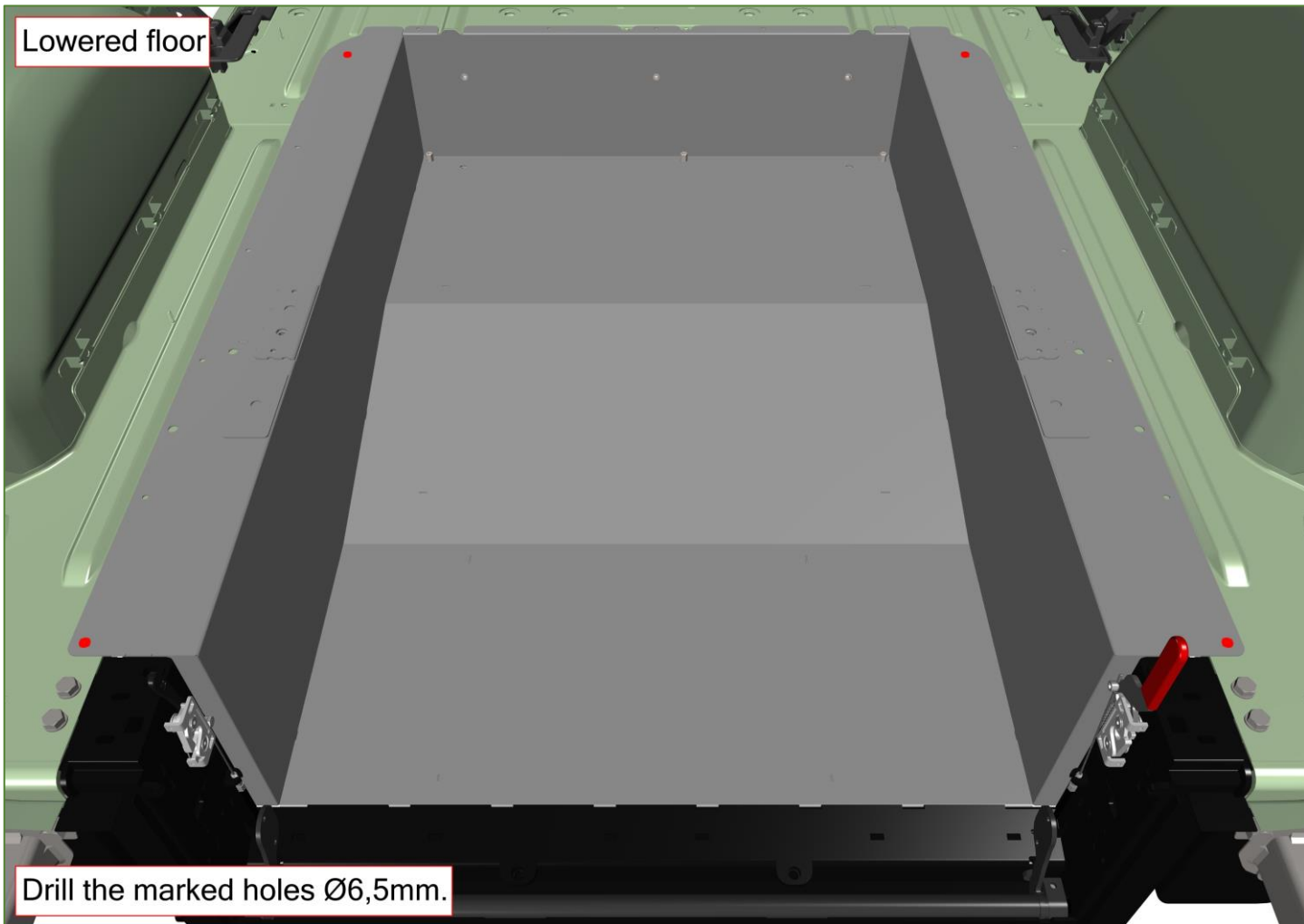

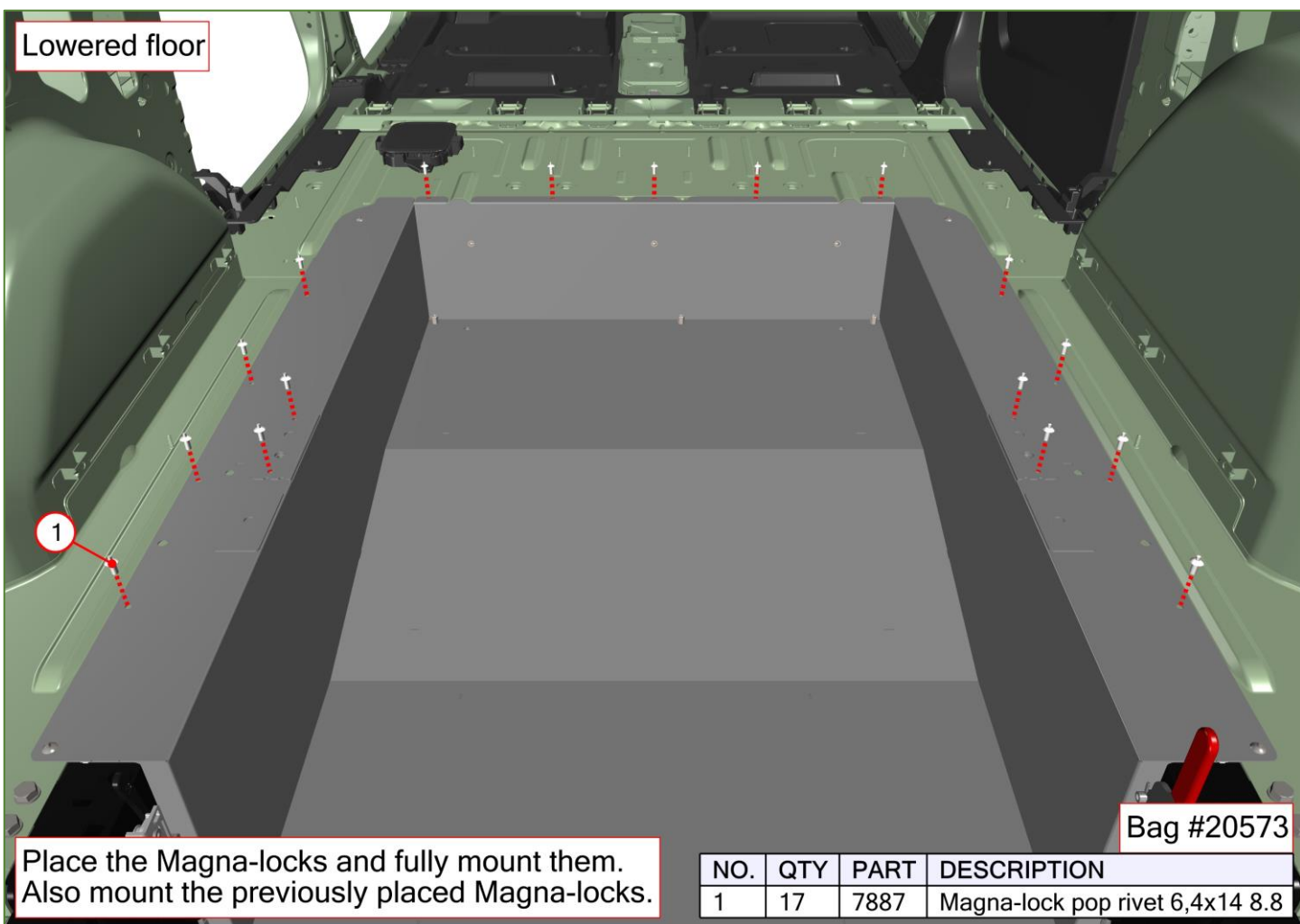
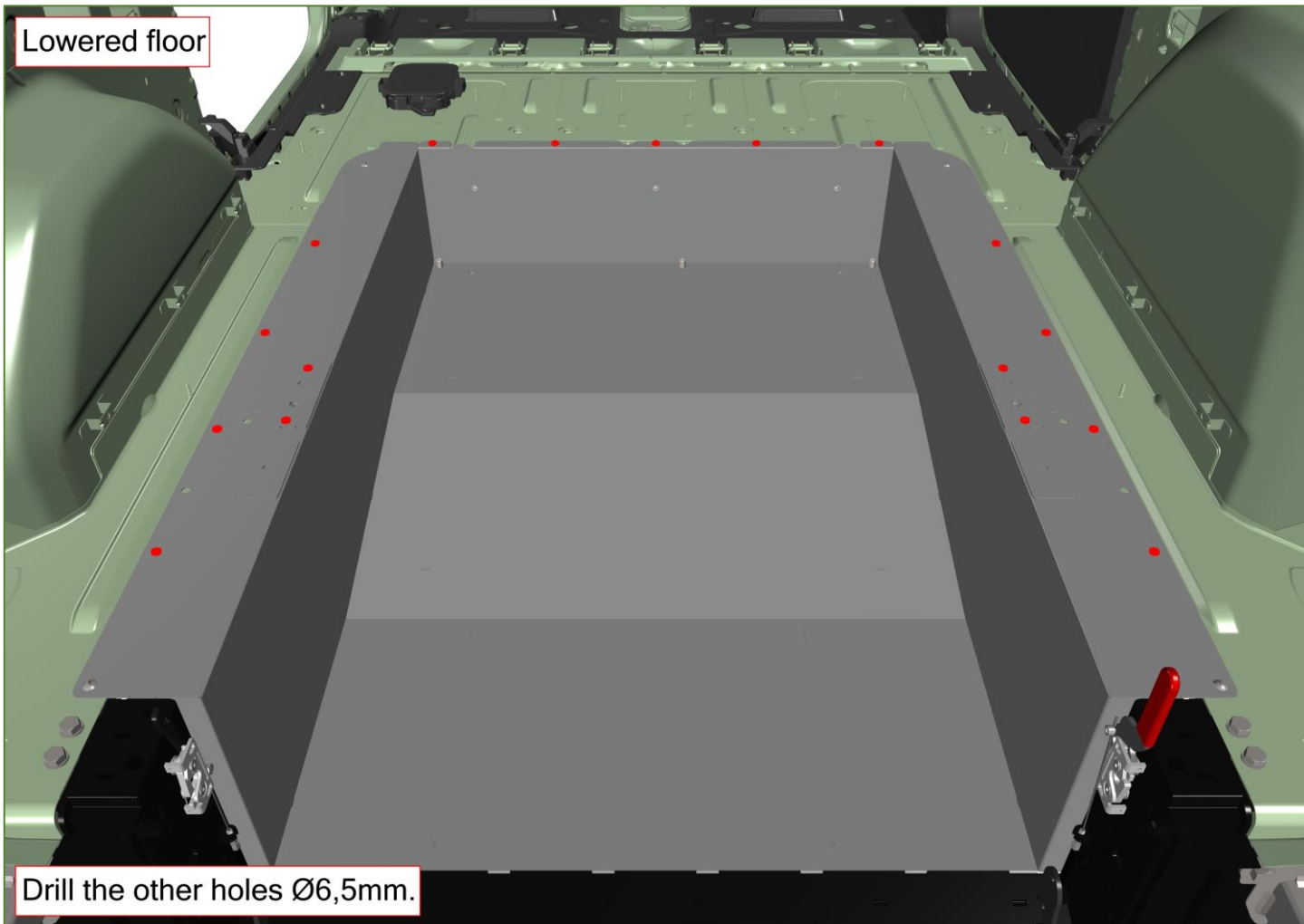

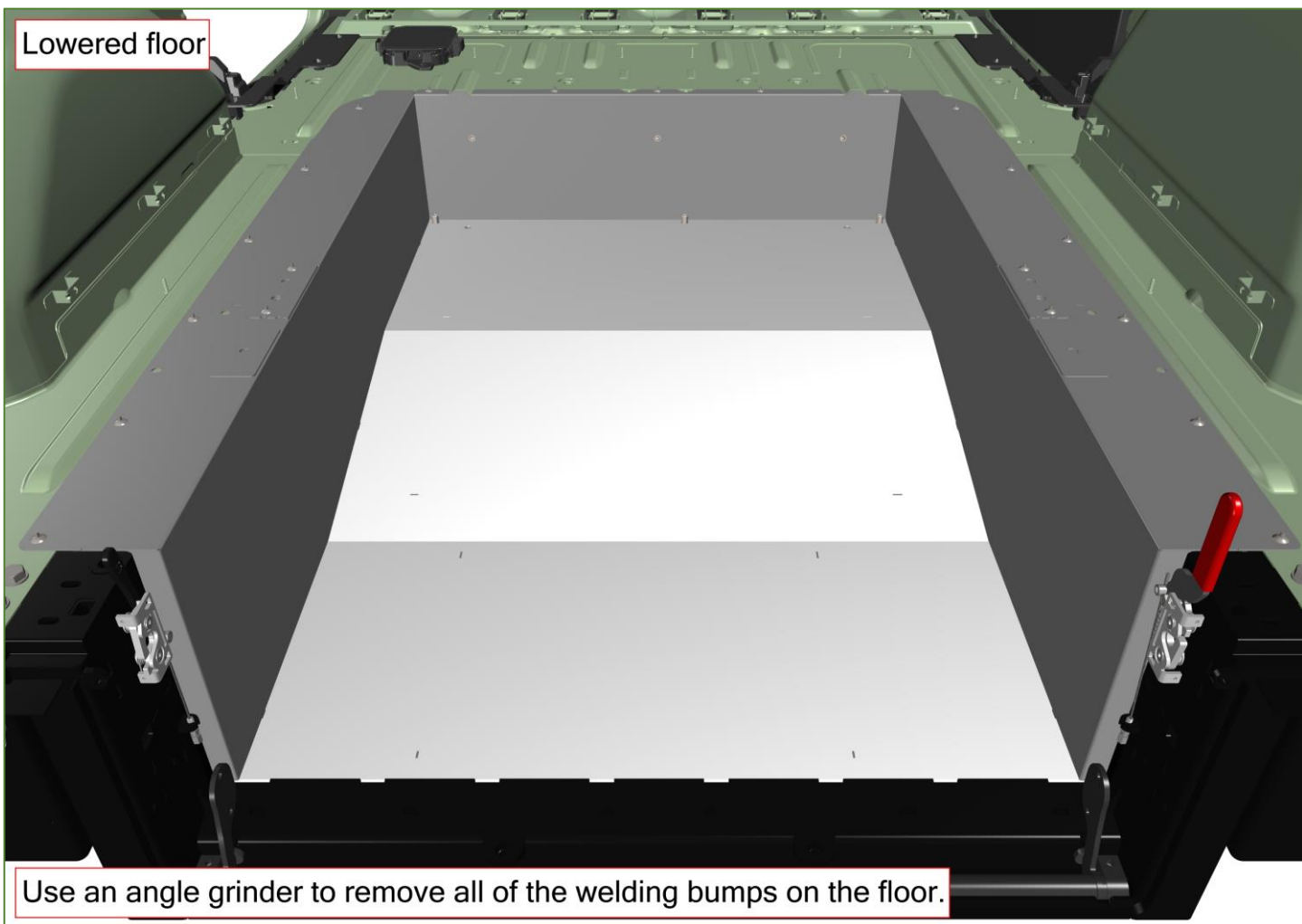
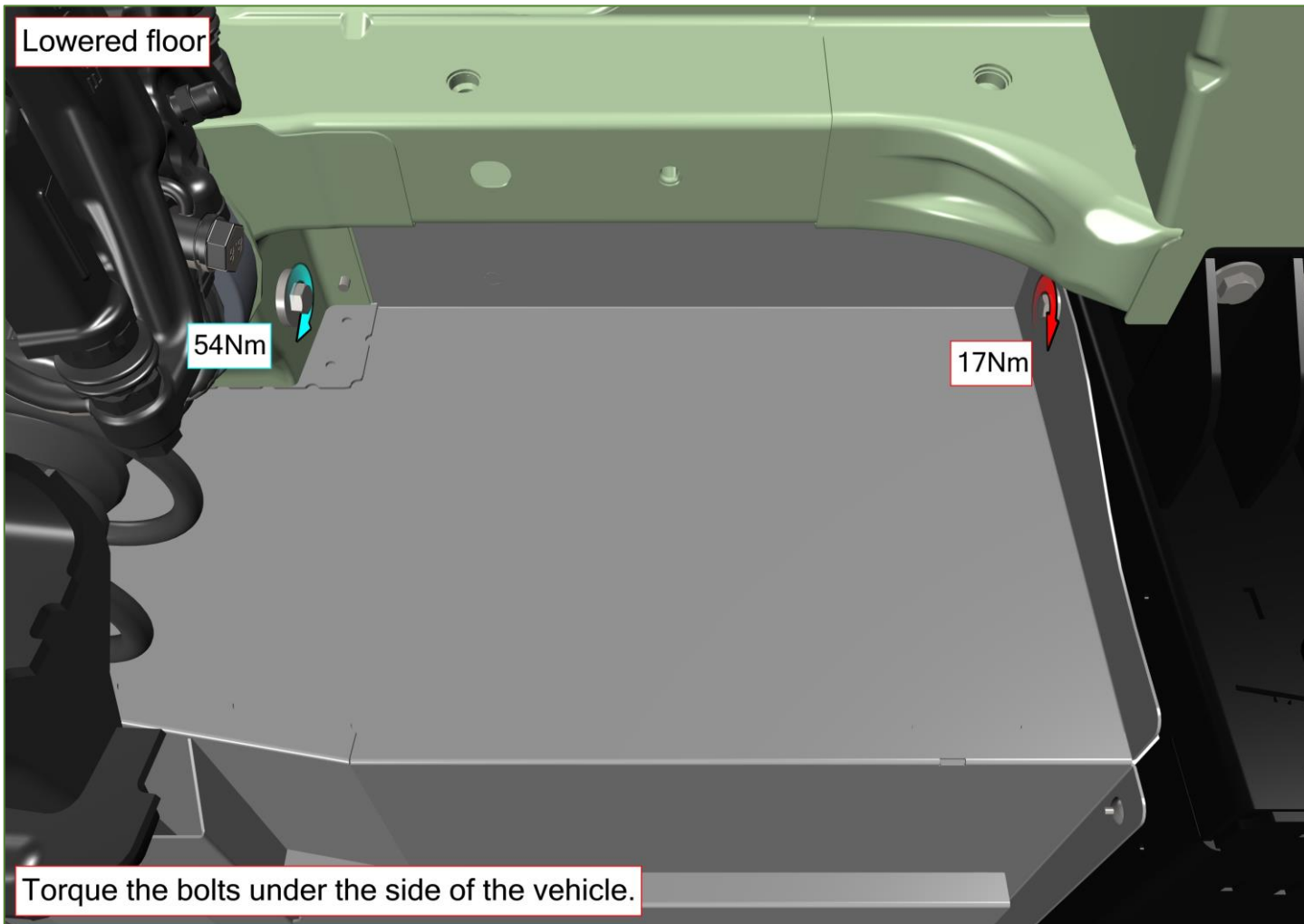



## How to seal



When applying sealant, first locate the edge or spot that needs sealant. Edges where 2 or more plates overlap each other or form a corner are an example. Also any spot where even a slight opening/gap from the outside to the inside of the vehicle or a closed beam is located.

## How to seal



Degrease the surfaces that the sealant will be applied to.



## How to seal



Position the sealant gun at the start of the edge.

## How to seal

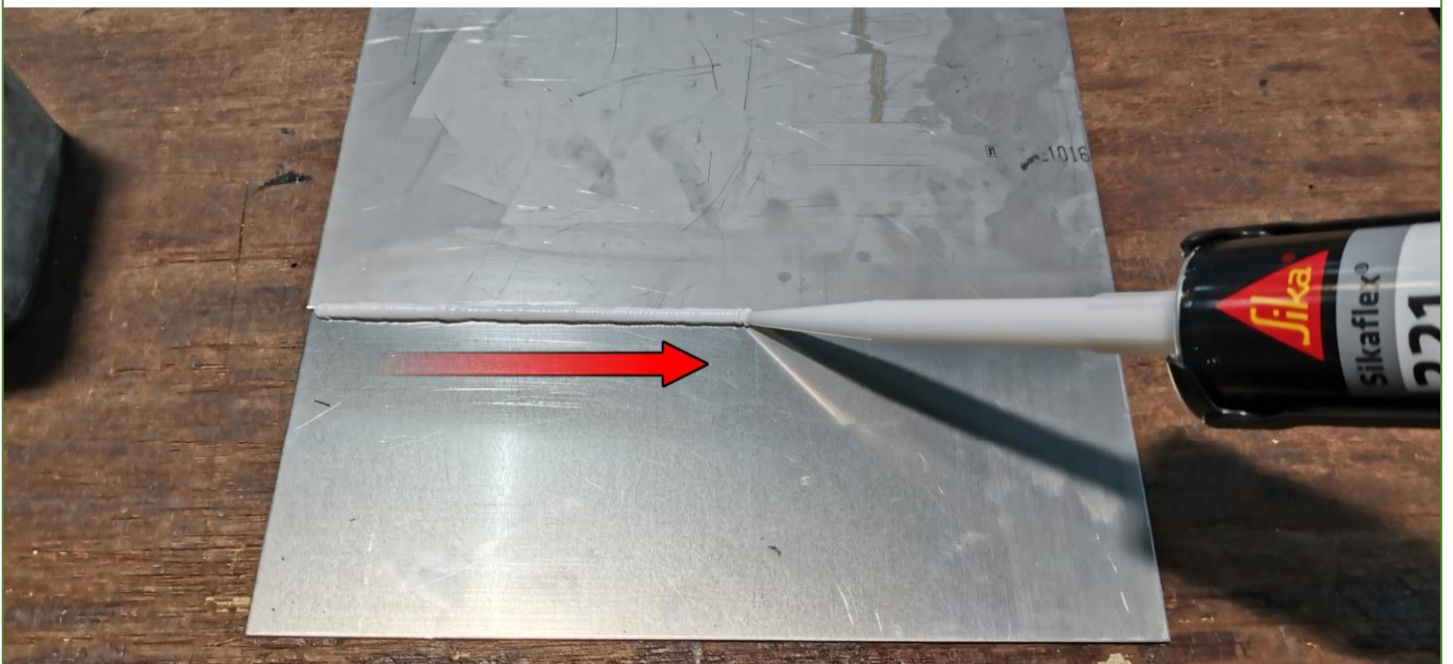

With a smooth and controlled motion, move the sealant gun along the edge to apply the sealant. Use the trigger with a controlled matter to create an even line of sealant.

## How to seal

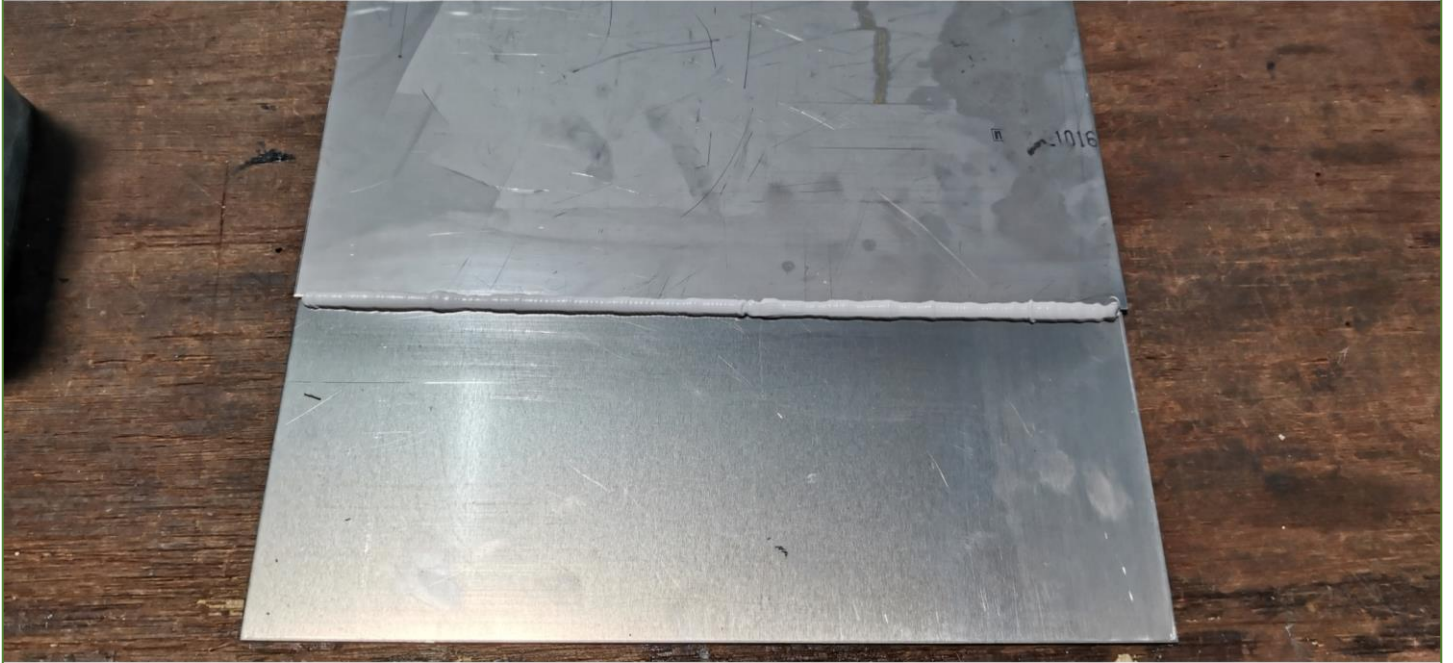

When done properly, the line of sealant should look like this. BEWARE, this is not the final step to properly seal.

## How to seal



To properly seal, the sealant must be spread out evenly by using a sealant bush.



## How to seal



Some people might prefer to cut the brush to a short size, this allows for more precise usage. This is not mandatory.

## How to seal



Some people might prefer to cut the brush to a short size, this allows for more precise usage. This is not mandatory.



How to seal



Start spreading the sealant with the brush.  
Start at the beginning of the sealant line.

How to seal



First use the brush in one direction.

## How to seal

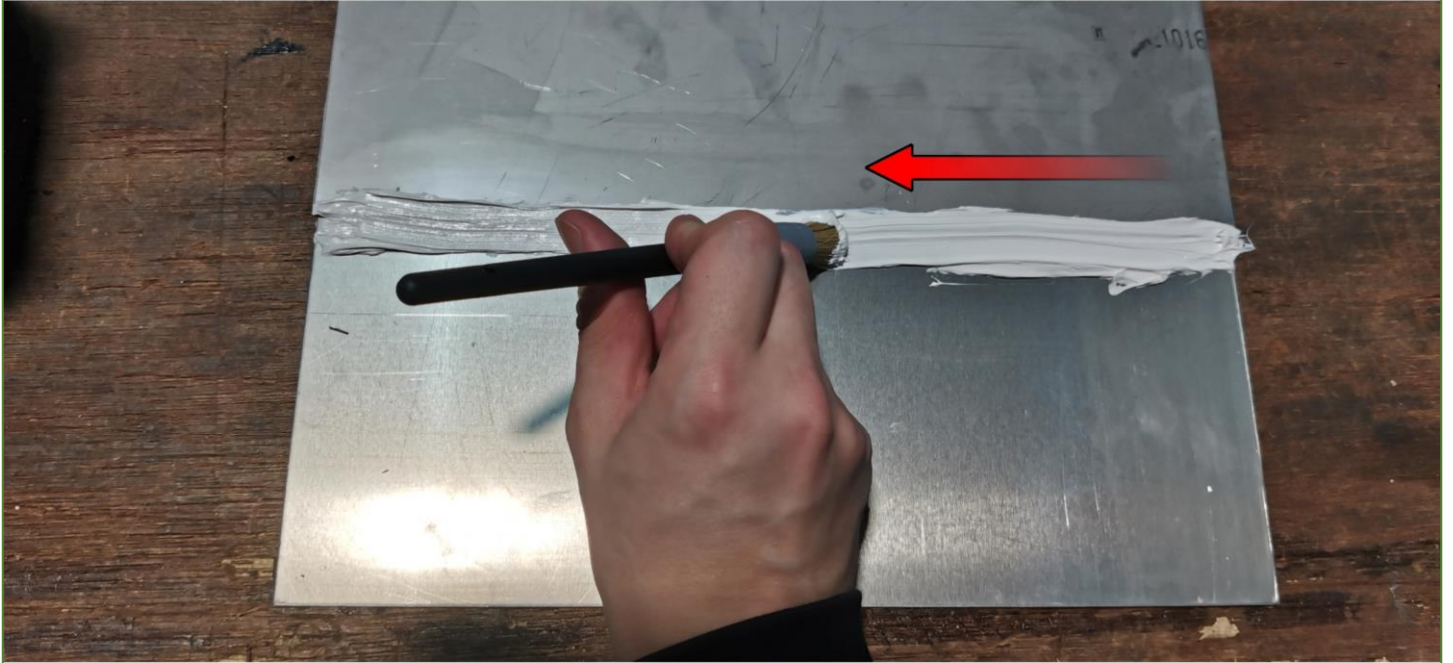

When finished in direction one, use the brush back in the other direction. This way the sealant will spread evenly and its use will be optimized.

## How to seal



Be sure to fully cover the edge/gap with sealant using the brush. If ALL edges and gaps have been covered, there should be no way possible for water to enter the vehicle where it could cause corrosion. Only then is has the sealant been applied properly.



## How to seal



After sealing, wipe the sealant off the brush and place the brush in a cup with turpentine to get the sealant out of the brush.

## Sealant

Seal the FULL edge of the lowered floor.

Using Sikaflex 221 white, seal every seam and gap where water could pass through. Seal ALL mounting points which extrude through the OEM floor, Every pop rivet, bolt/nut and threaded plate.

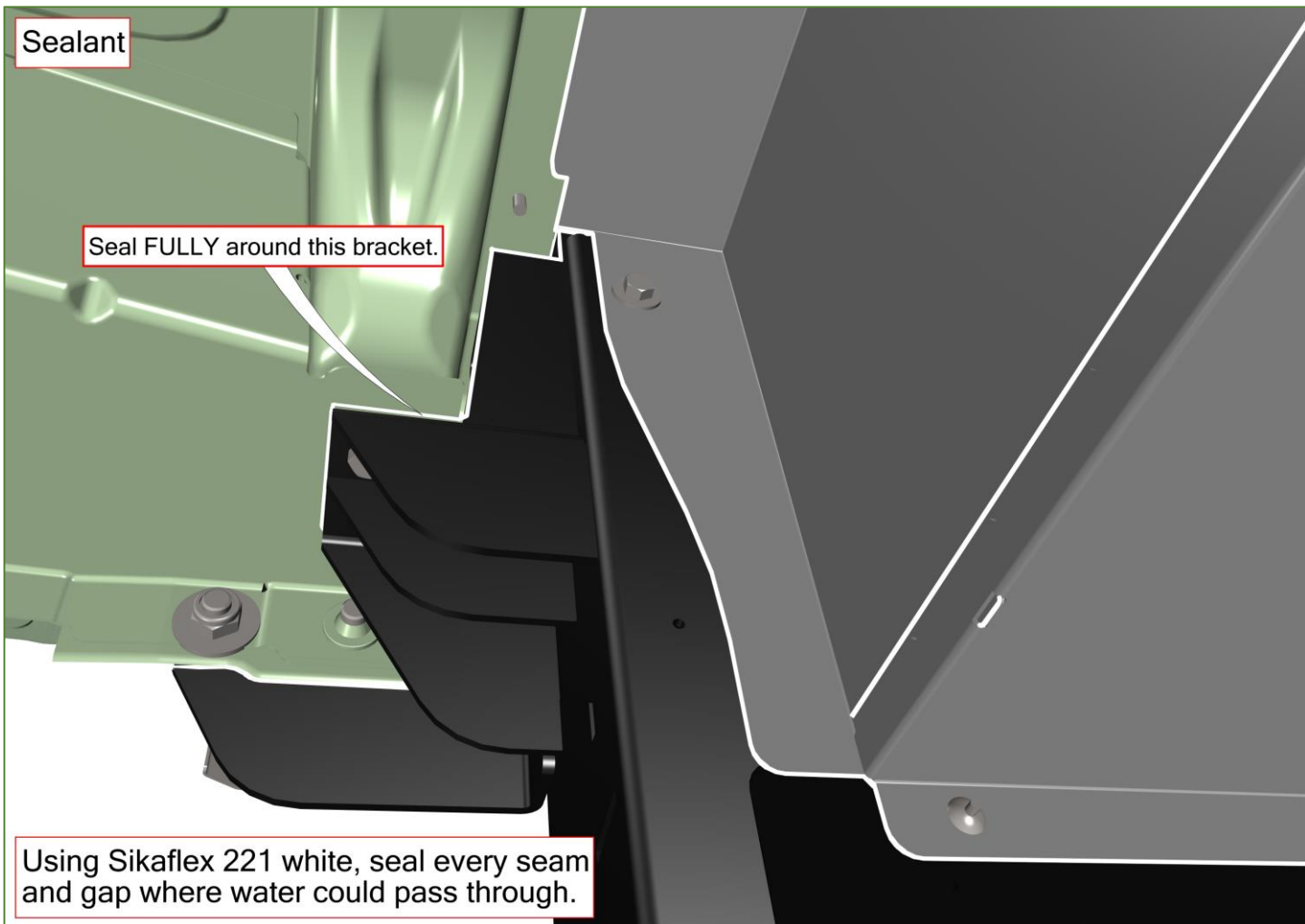
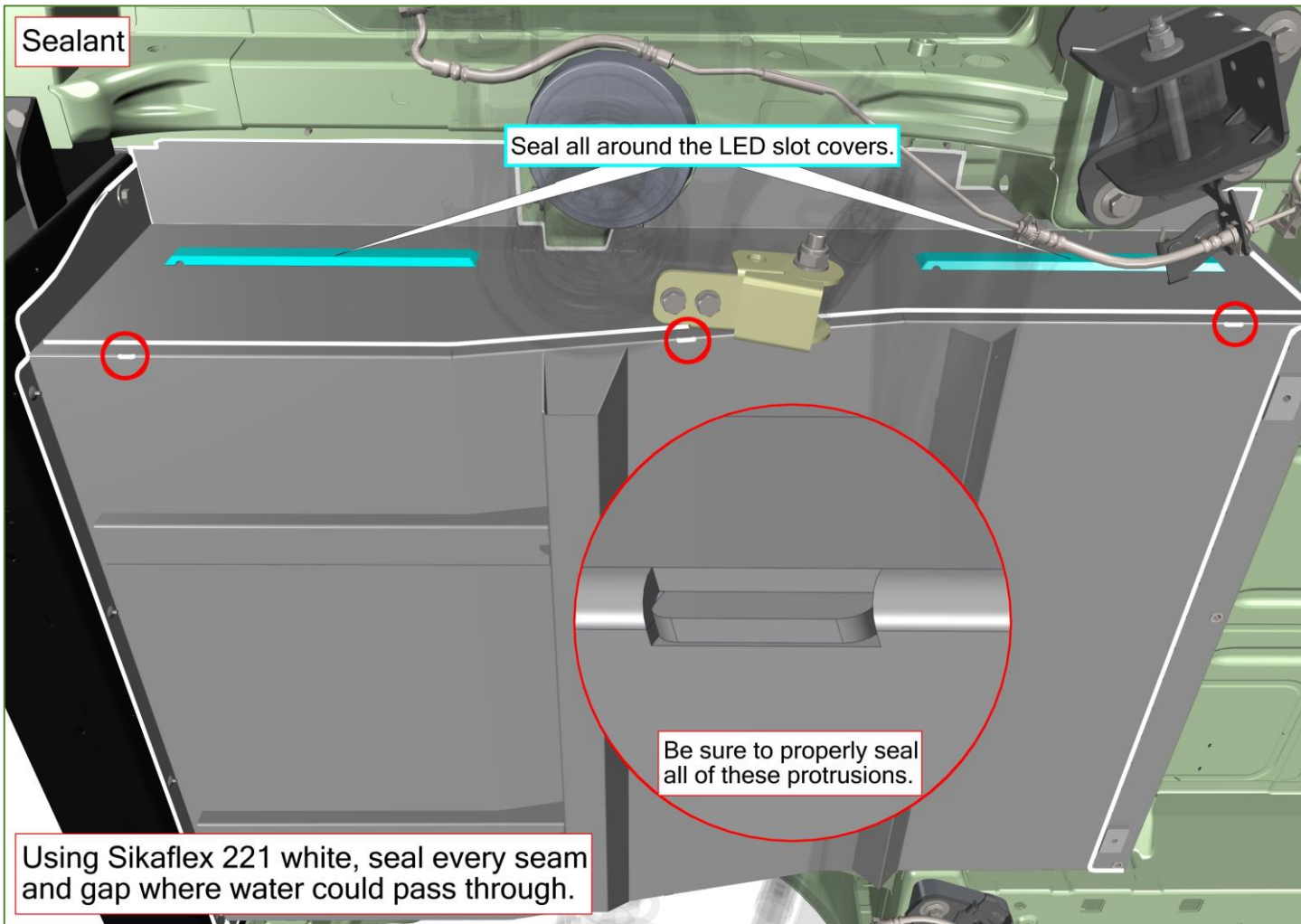

Sealant

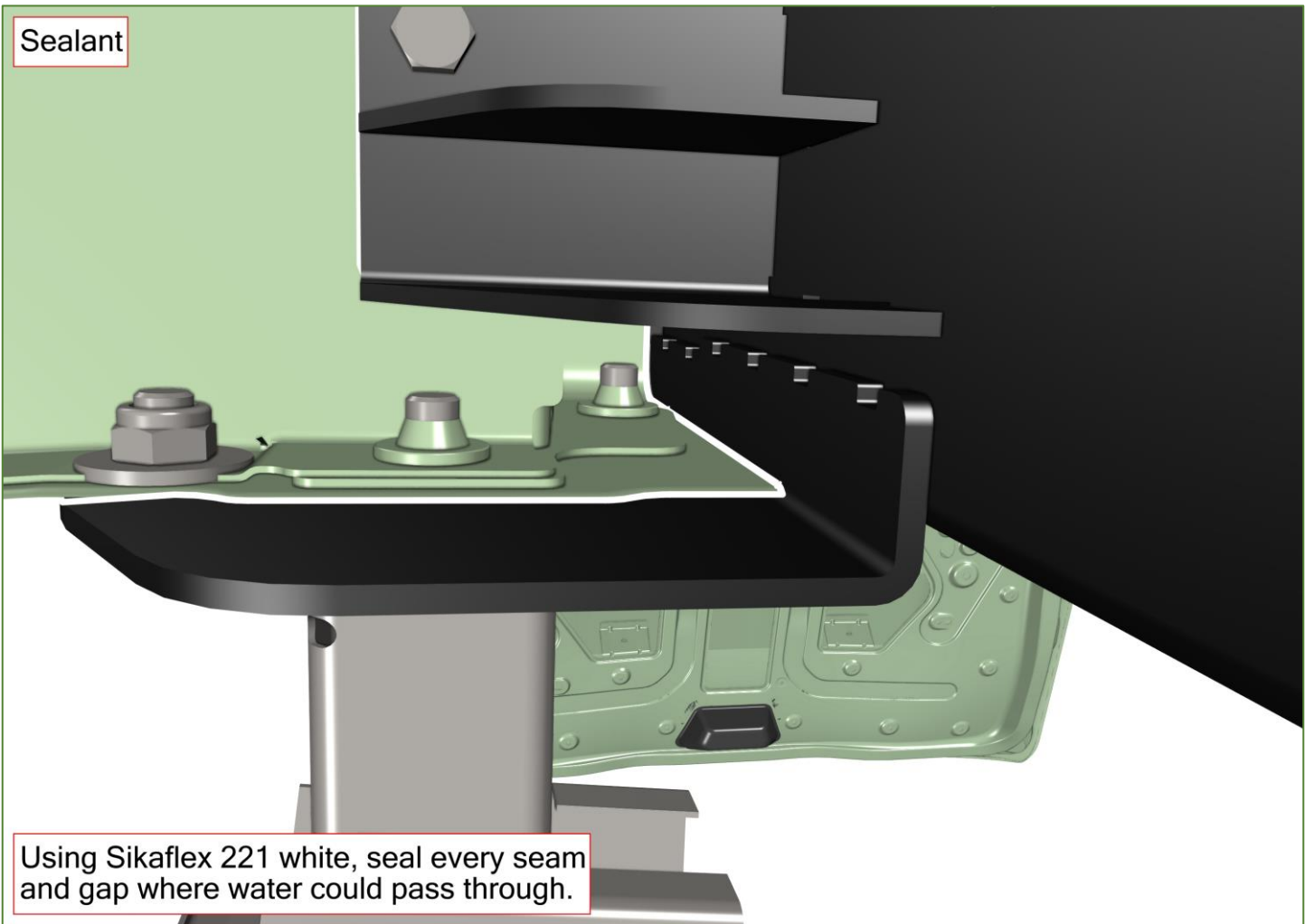

Using Sikaflex 221 white, seal every seam and gap where water could pass through.

Sealant

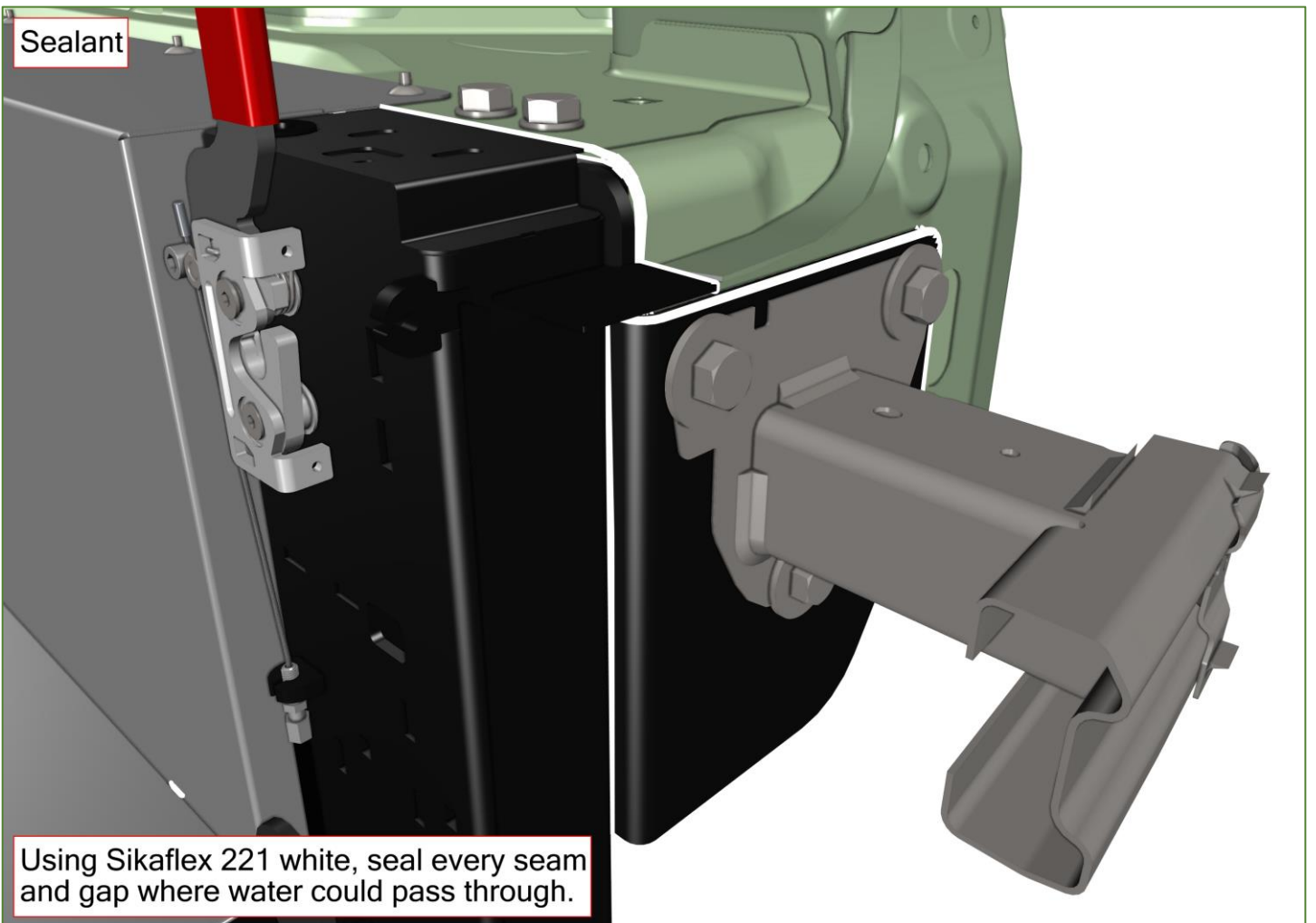

Using Sikaflex 221 white, seal every seam and gap where water could pass through.



It is VERY IMPORTANT to let the sealant dry overnight!  
Only when the sealant is completely dry you can tectyl the chassis and the floor.  
On the inside of the car: use tape to close EVERY hole/opening to protect the interior.  
Tectyl the floor using:  
- Tectyl Terotex HV450 in all hollow beams and compartments  
- Tectyl Terotex aqua 3000 on the entire lowered floor  
or 3M anti stone chill protection waterbaseblack 1L 08881

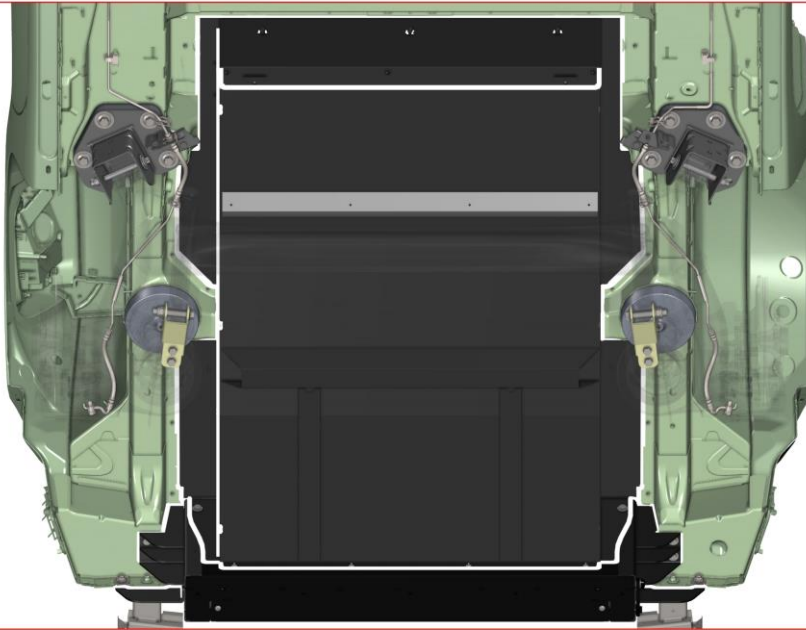

Do NOT work on the bottom of the car once tectyl has been applied until it's dry, wait about 24h. In the meantime, work on the interior/wiring/bumper etc.

### 3-point belt preparation

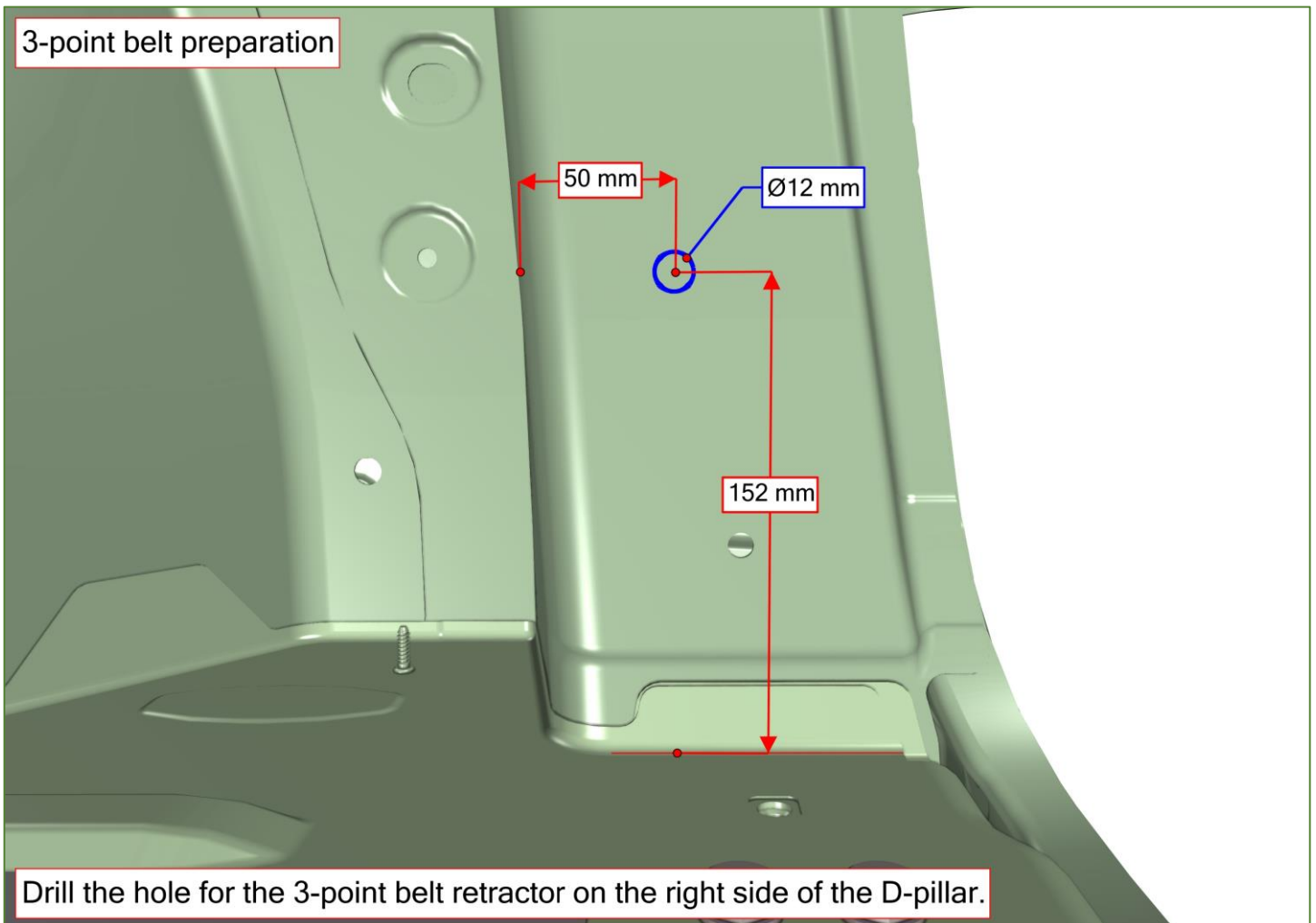

Drill the hole for the 3-point belt retractor on the right side of the D-pillar.

3-point belt preparation

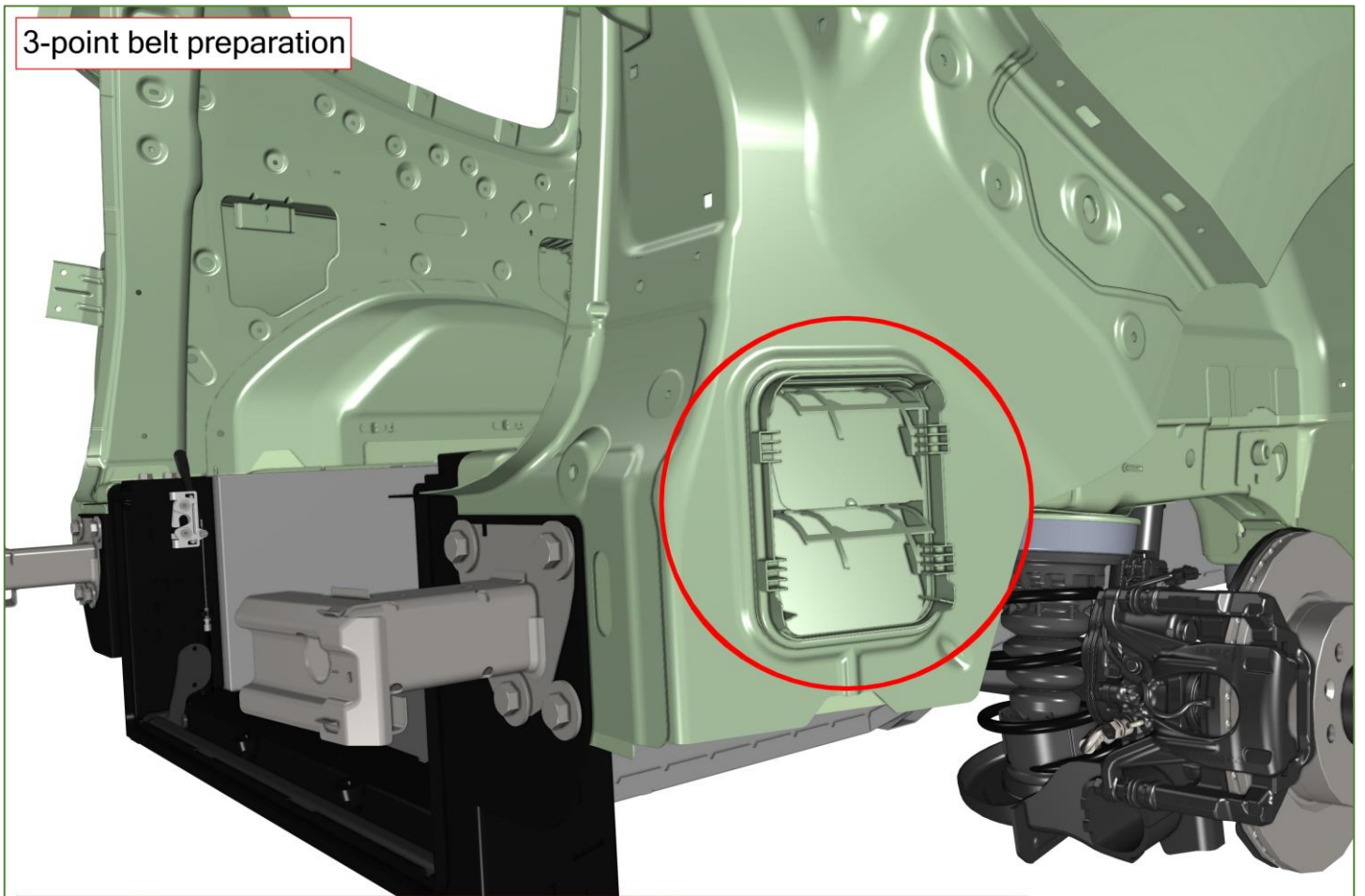

Open the breather by taking the plastic unit and fabric out of the D-pillar.

3-point belt preparation

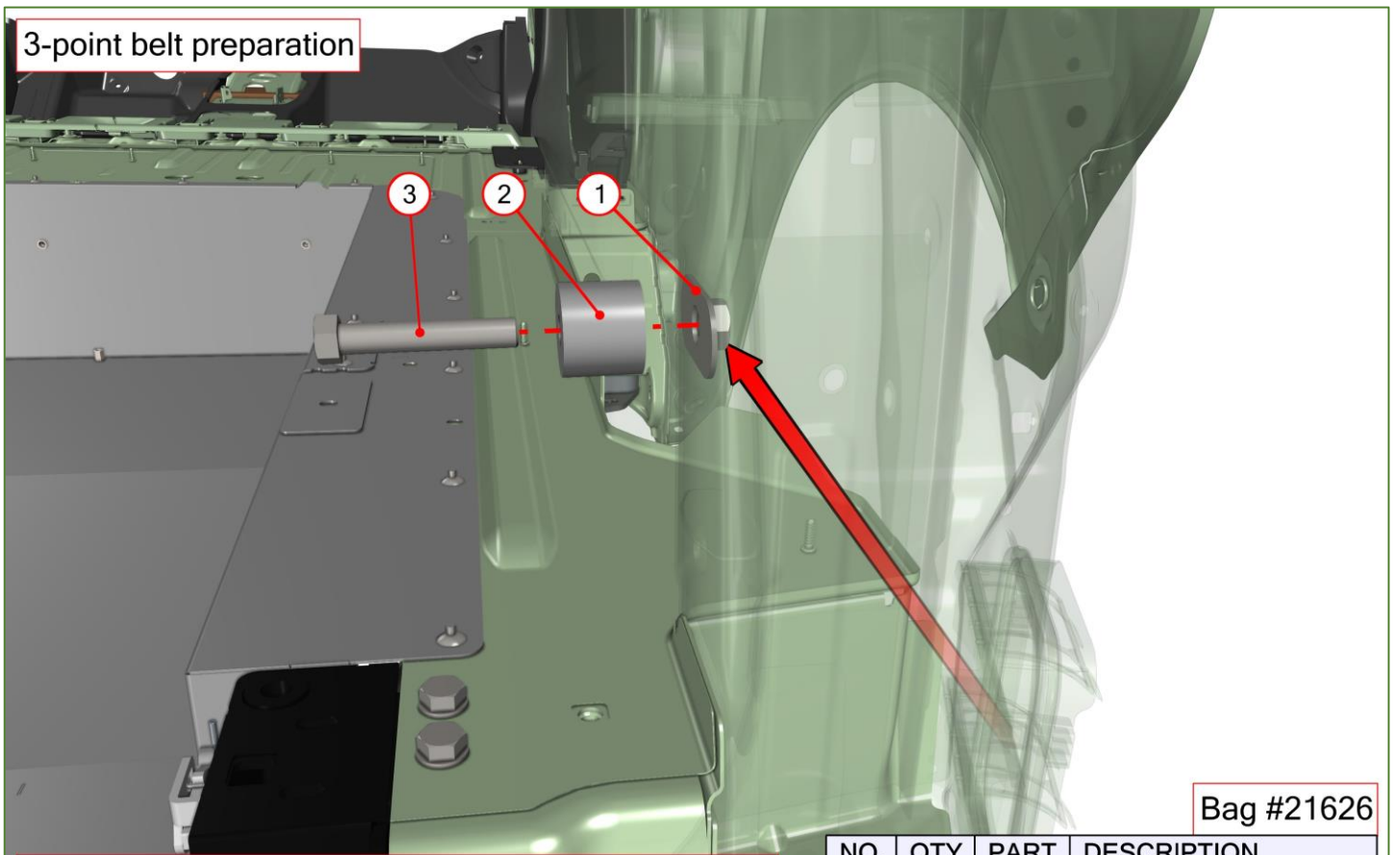

Bag #21626

Mount the threaded plate using the bolt and bushing. Make sure the threaded plate is positioned flat as shown.

NO.	QTY	PART	DESCRIPTION
1	1	8728	7/16 UNF treaded plate
2	1	19896	Spacer di12/D35/L30
3	1	4460	Hex bolt UNF 7/16 x 2,5"

### 3-point belt preparation

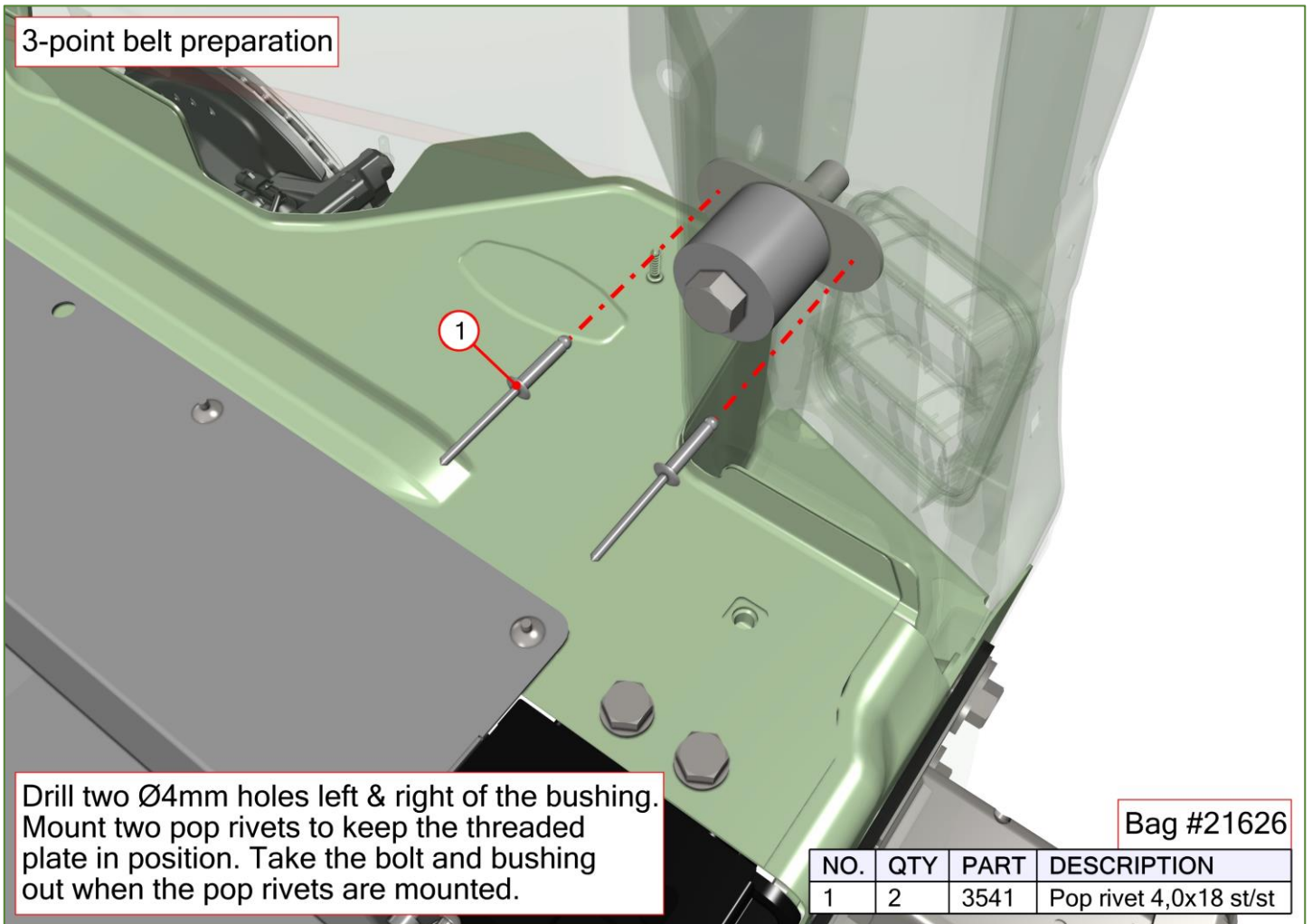

Drill two Ø4mm holes left & right of the bushing. Mount two pop rivets to keep the threaded plate in position. Take the bolt and bushing out when the pop rivets are mounted.

Bag #21626

NO.	QTY	PART	DESCRIPTION
1	2	3541	Pop rivet 4,0x18 st/st

### 3-point belt preparation

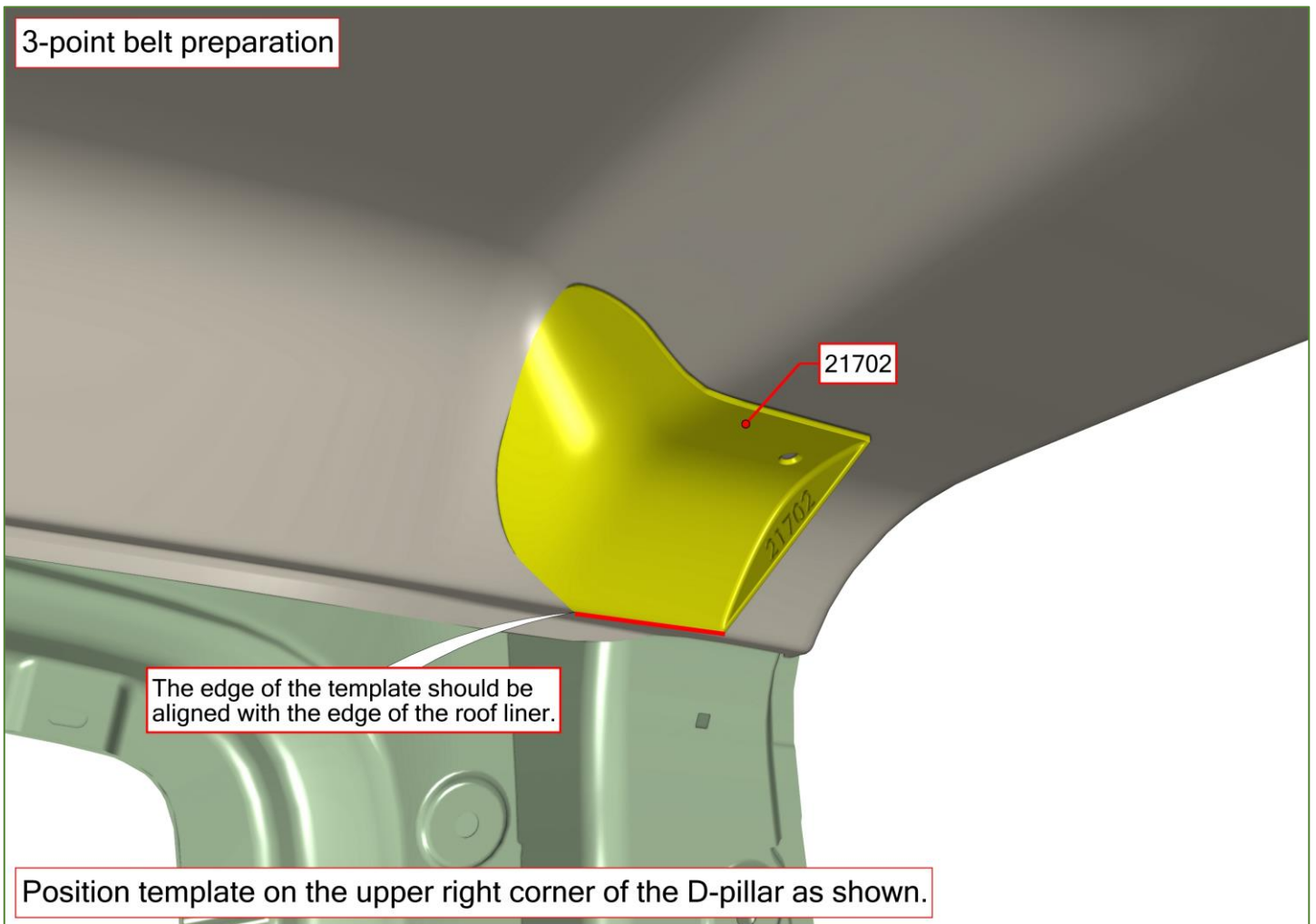

The edge of the template should be aligned with the edge of the roof liner.

Position template on the upper right corner of the D-pillar as shown.



3-point belt preparation

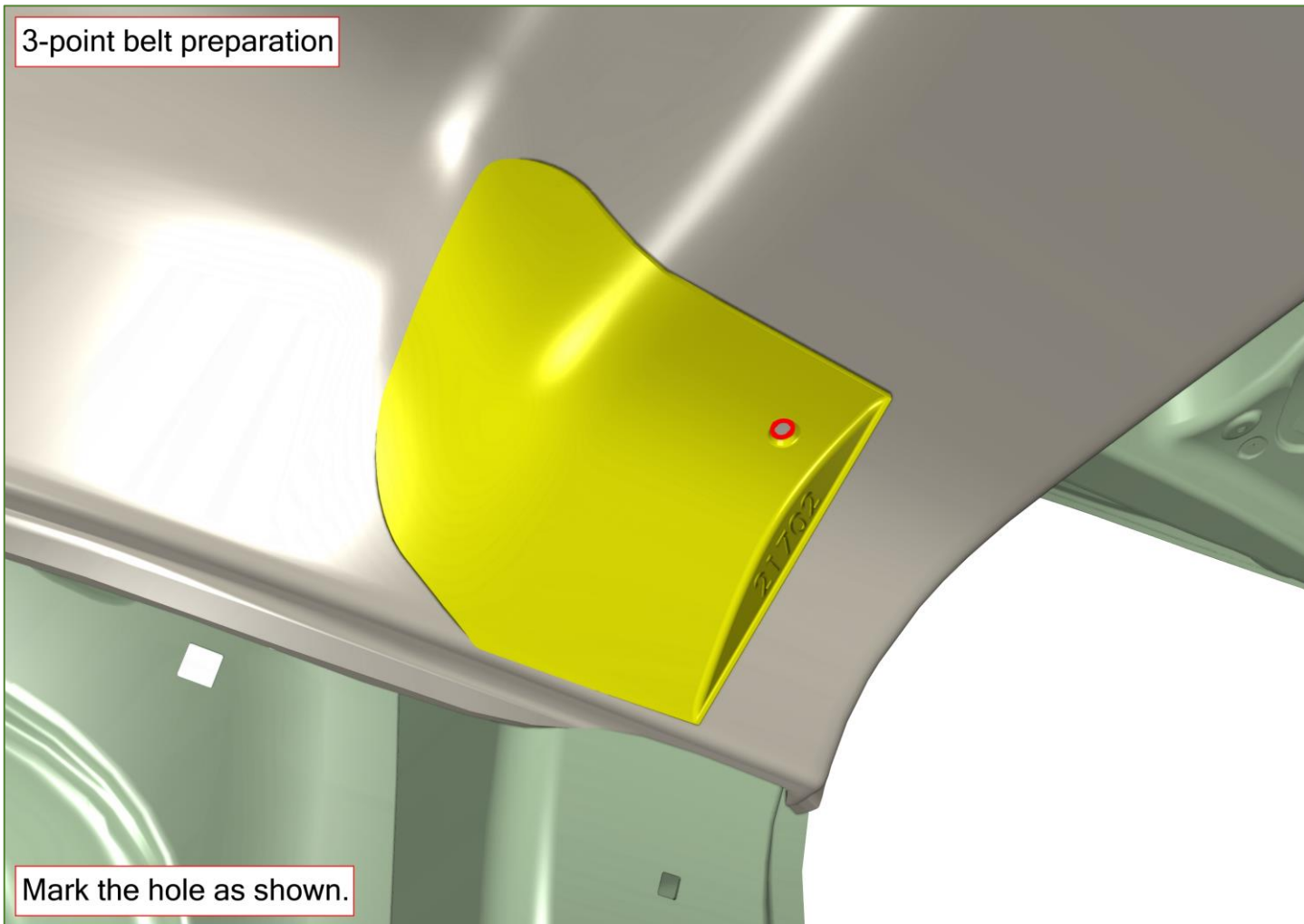

Mark the hole as shown.

3-point belt preparation

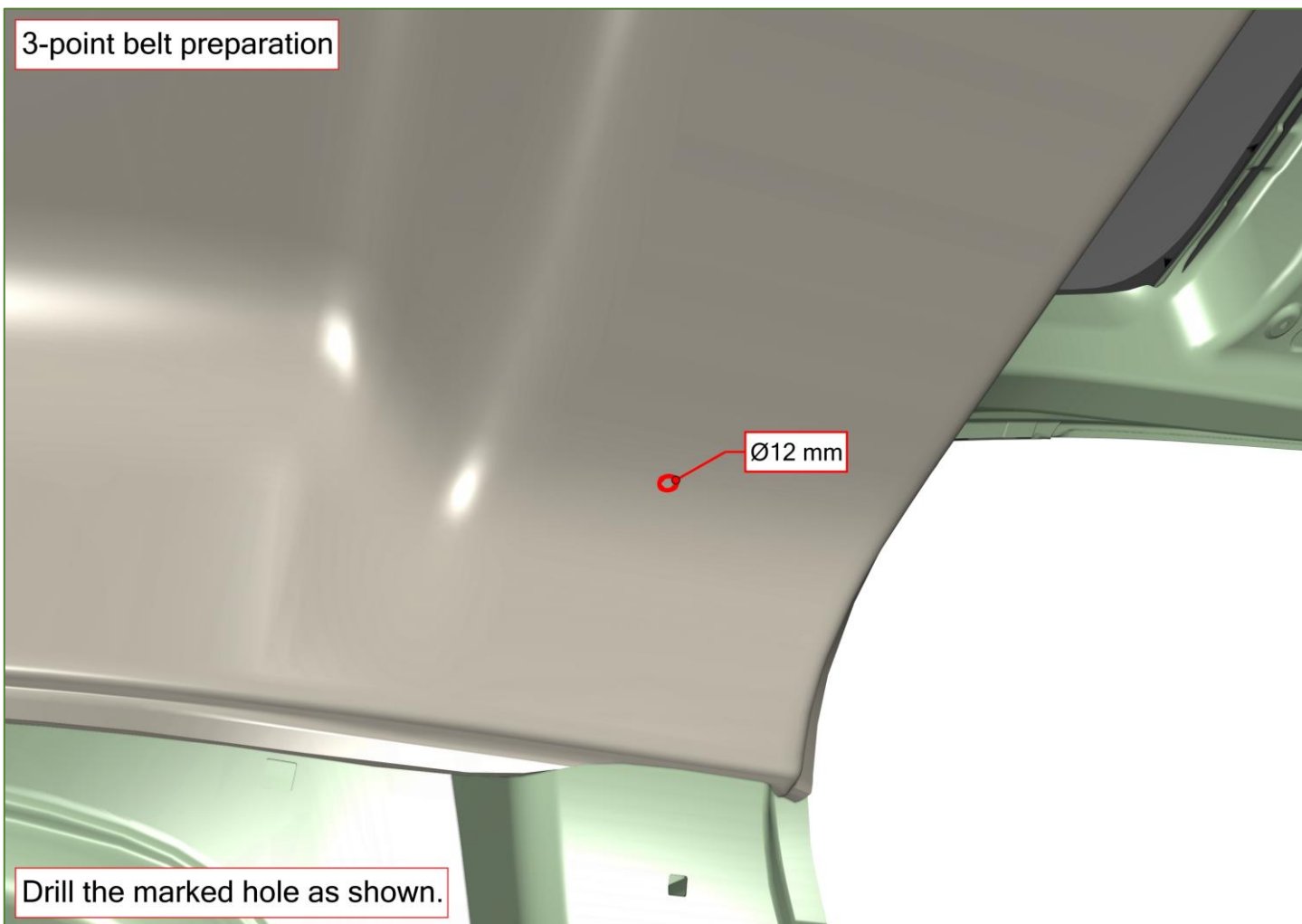

Drill the marked hole as shown.

3-point belt preparation

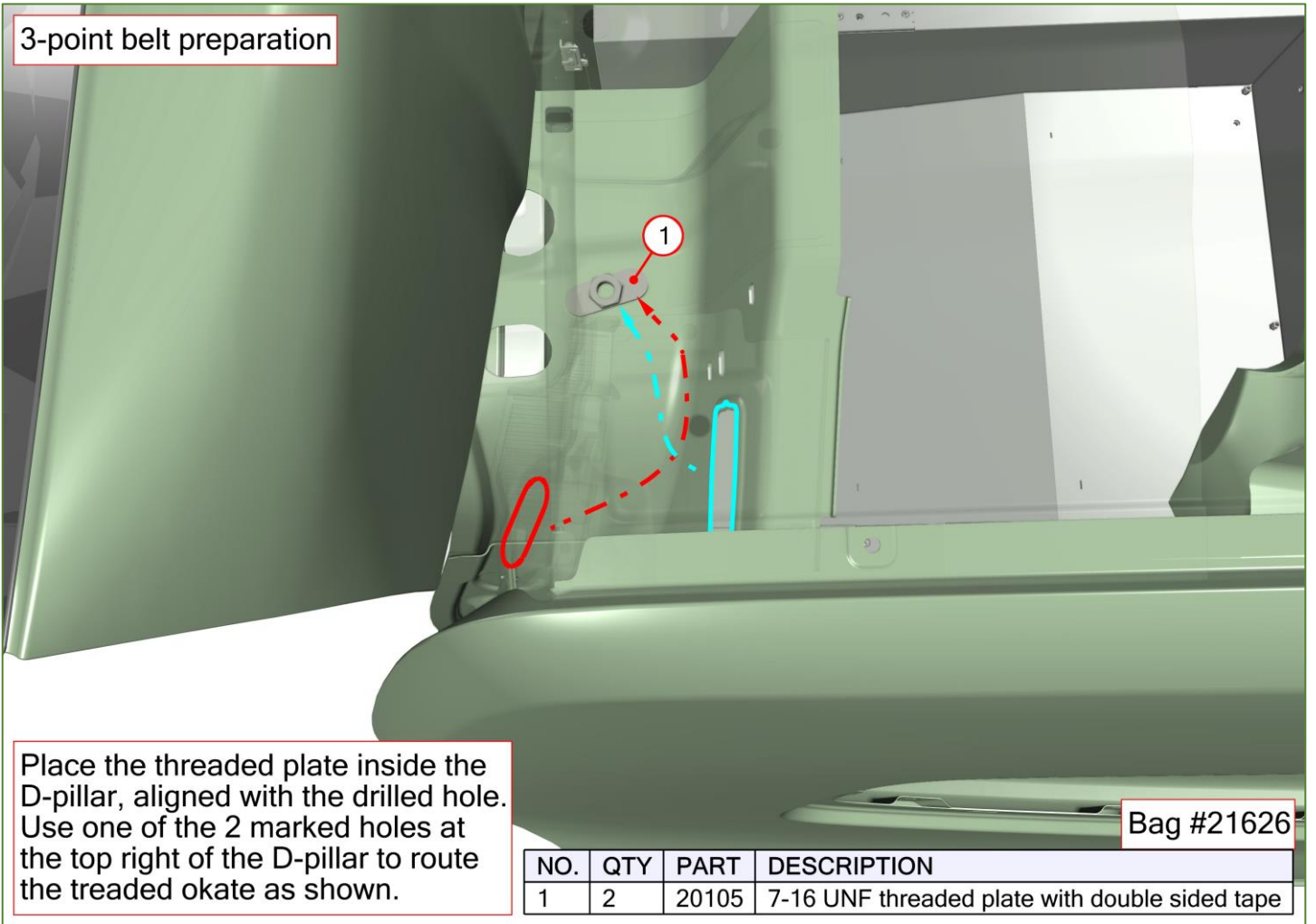

Place the threaded plate inside the D-pillar, aligned with the drilled hole. Use one of the 2 marked holes at the top right of the D-pillar to route the threaded okate as shown.

Bag #21626

NO.	QTY	PART	DESCRIPTION
1	2	20105	7-16 UNF threaded plate with double sided tape

3-point belt preparation



Use the bolt to keep the threaded plate in place.

Bag #21626

NO.	QTY	PART	DESCRIPTION
1	1	-	Hex bolt UNF 7/16 x 1 3/4"

TriflexAir seat bracket

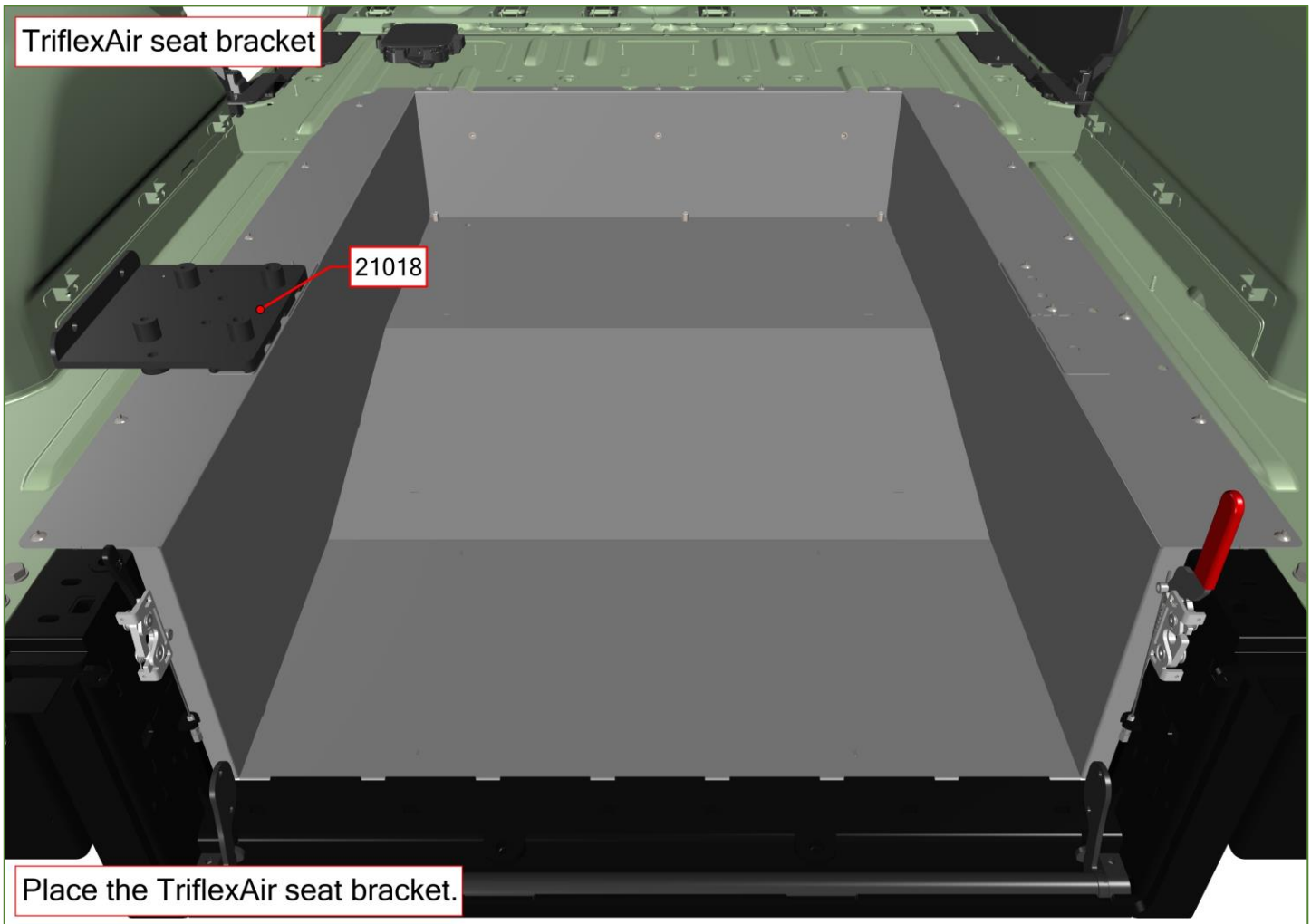

21018

Place the TriflexAir seat bracket.

TriflexAir seat bracket

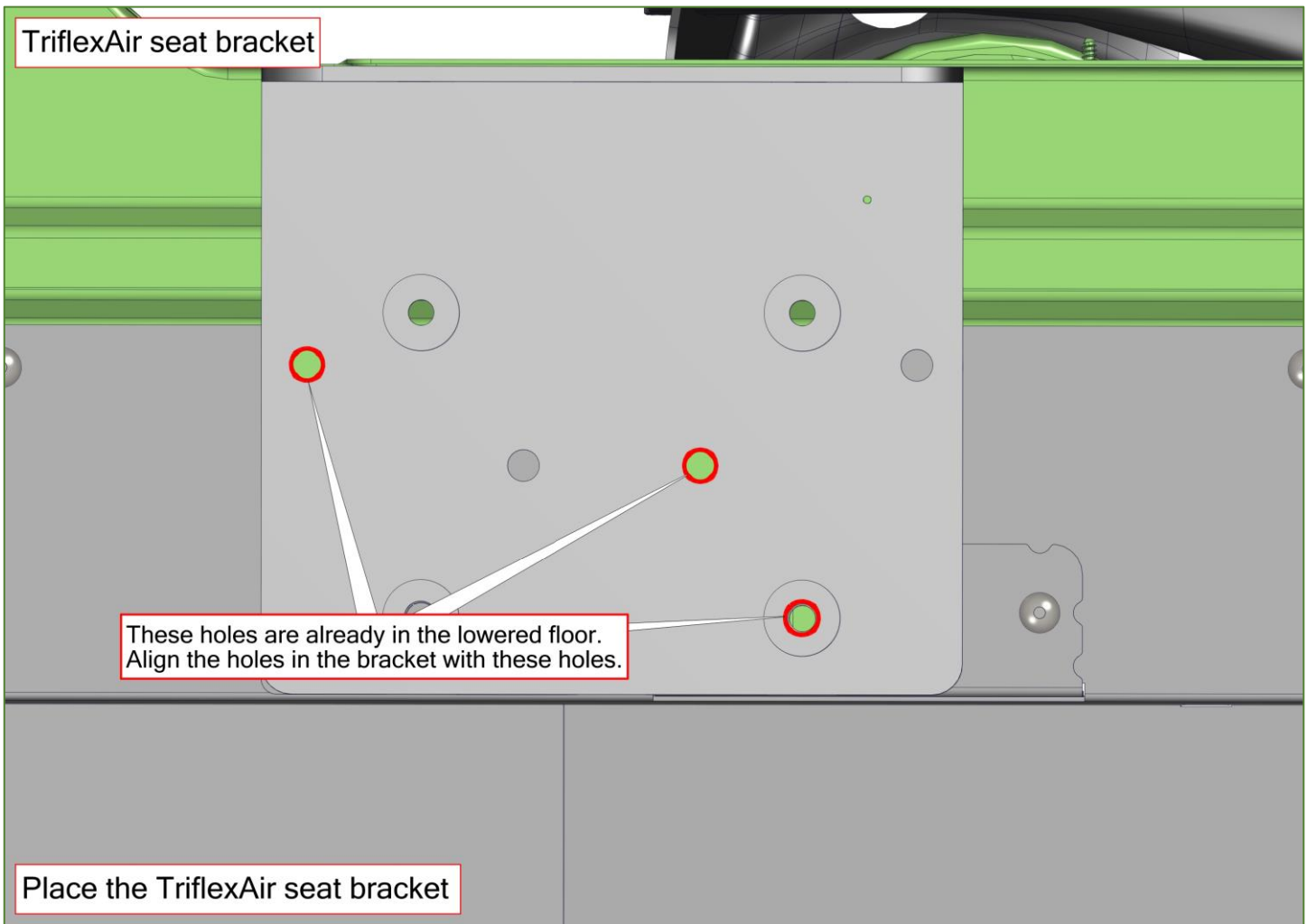

These holes are already in the lowered floor.  
Align the holes in the bracket with these holes.

Place the TriflexAir seat bracket



TriflexAir seat bracket

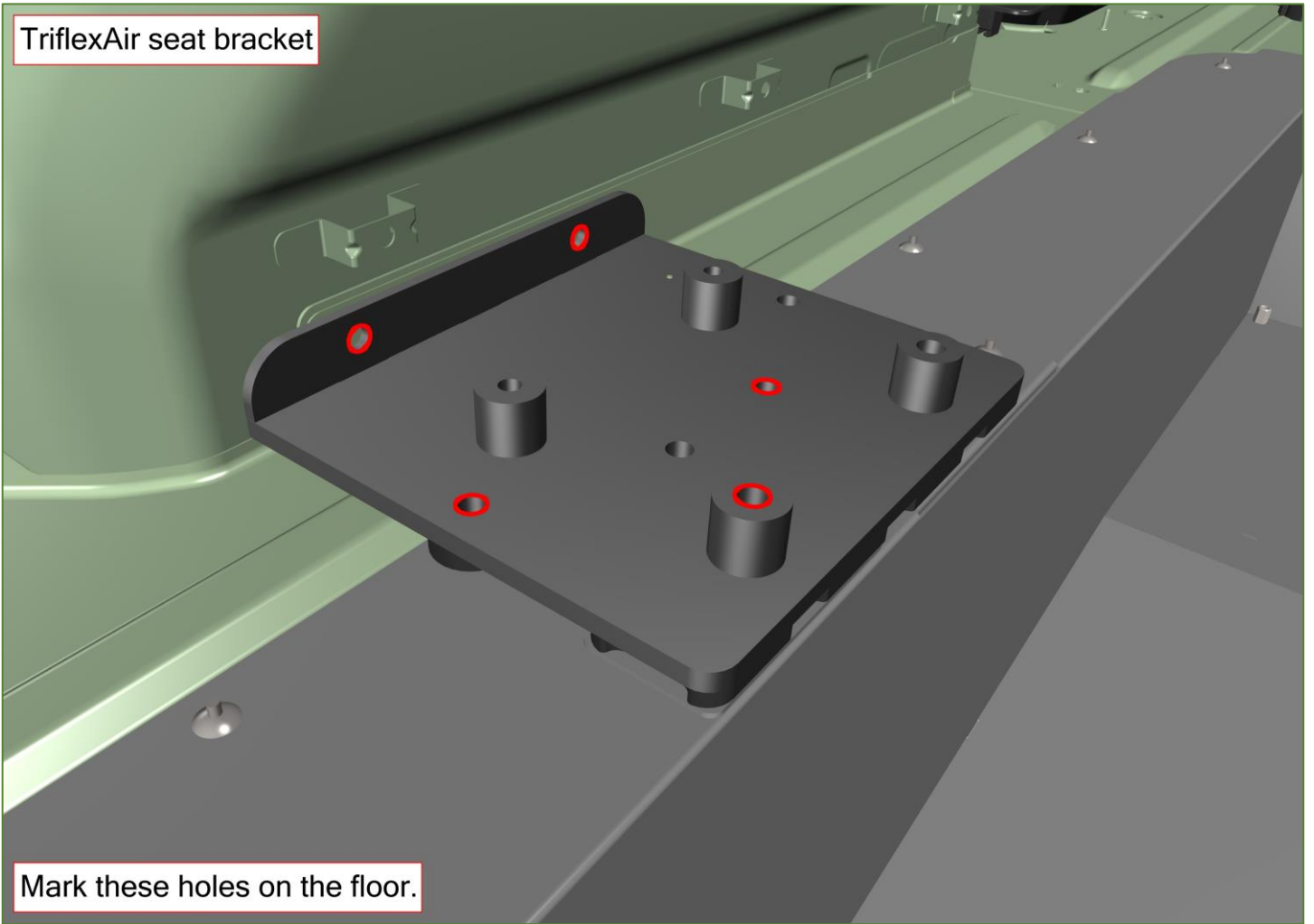

Mark these holes on the floor.

TriflexAir seat bracket

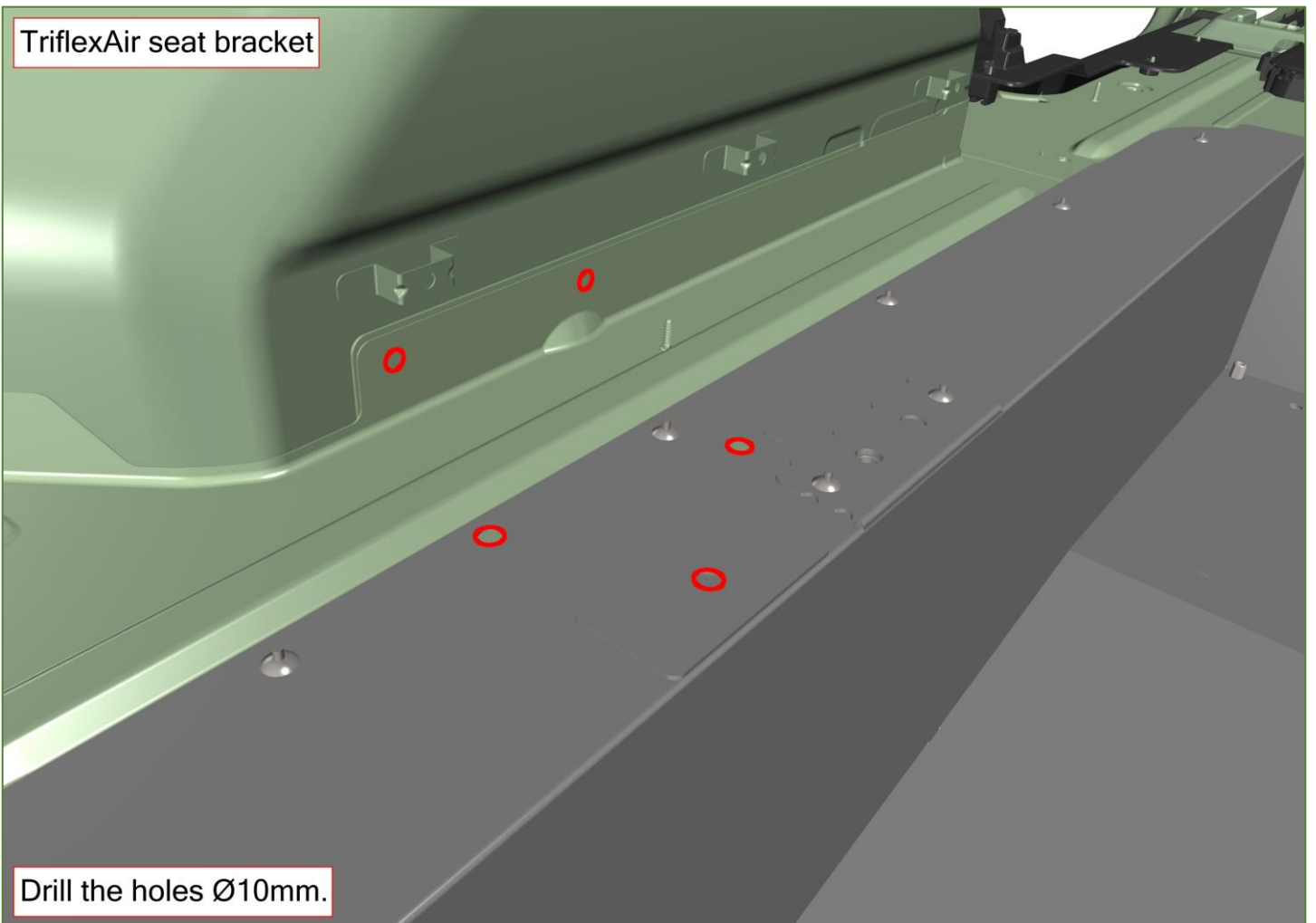

Drill the holes Ø10mm.

TriflexAir seat bracket

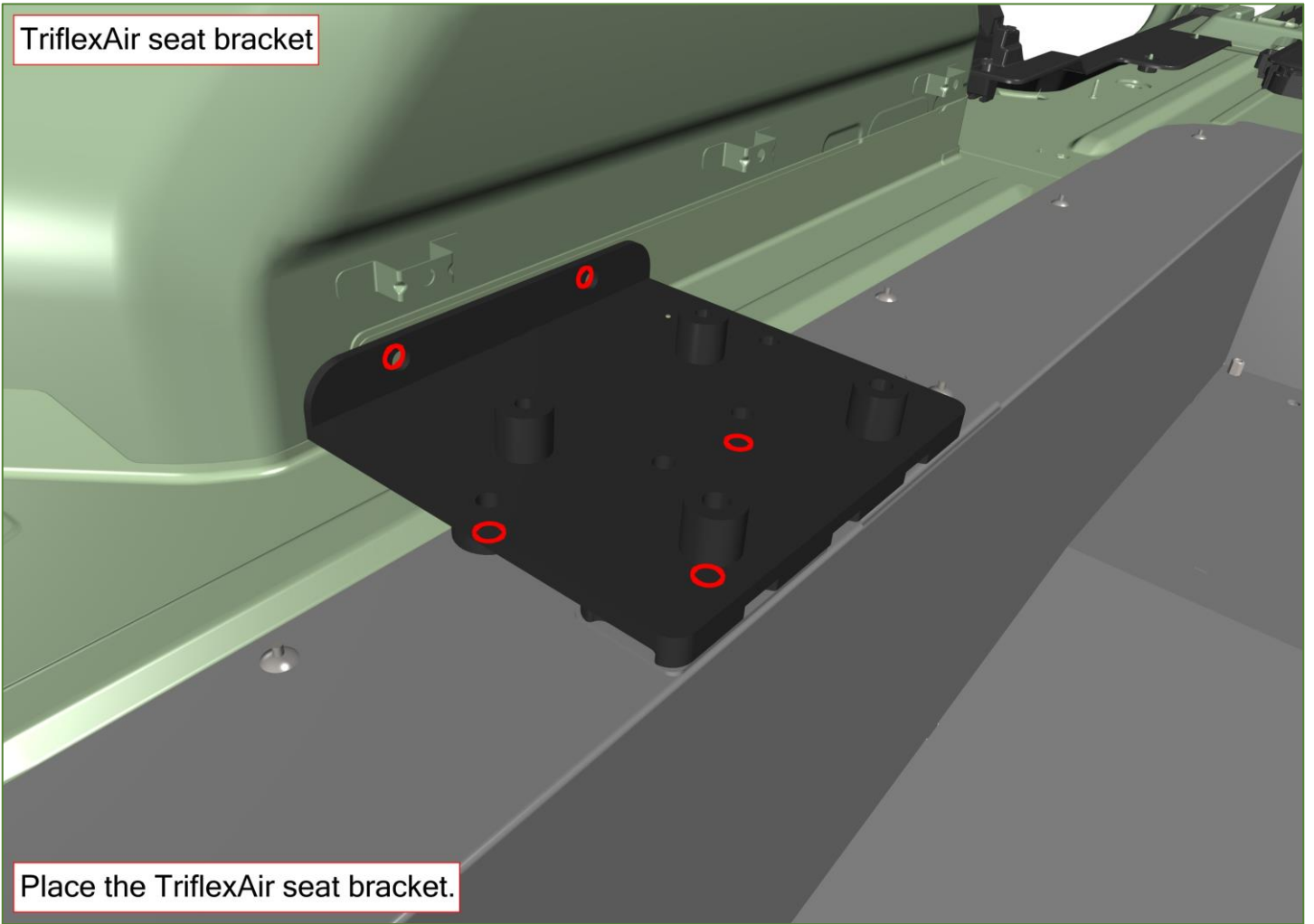

Place the TriflexAir seat bracket.

TriflexAir seat bracket

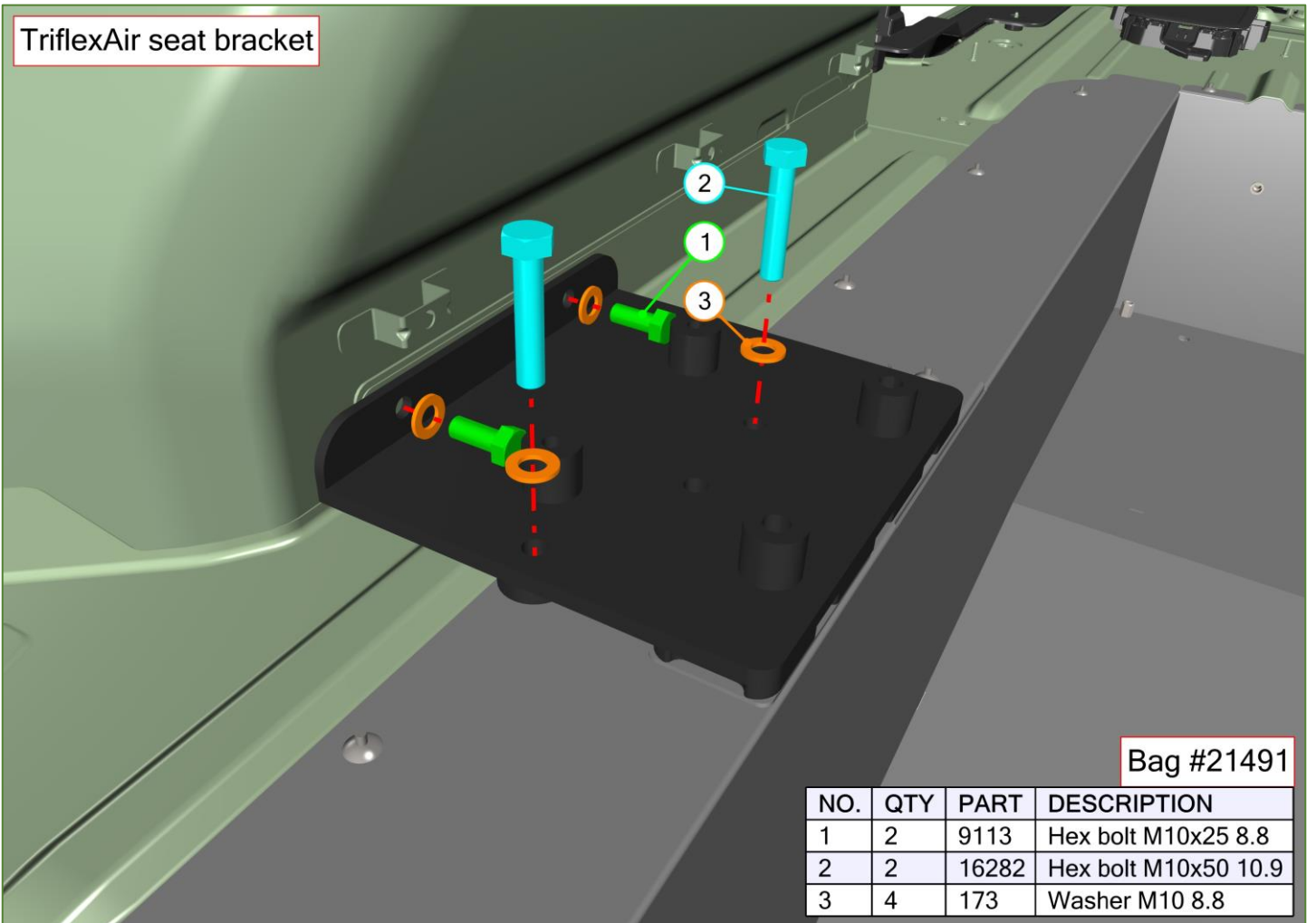

Bag #21491

NO.	QTY	PART	DESCRIPTION
1	2	9113	Hex bolt M10x25 8.8
2	2	16282	Hex bolt M10x50 10.9
3	4	173	Washer M10 8.8



TriflexAir seat bracket

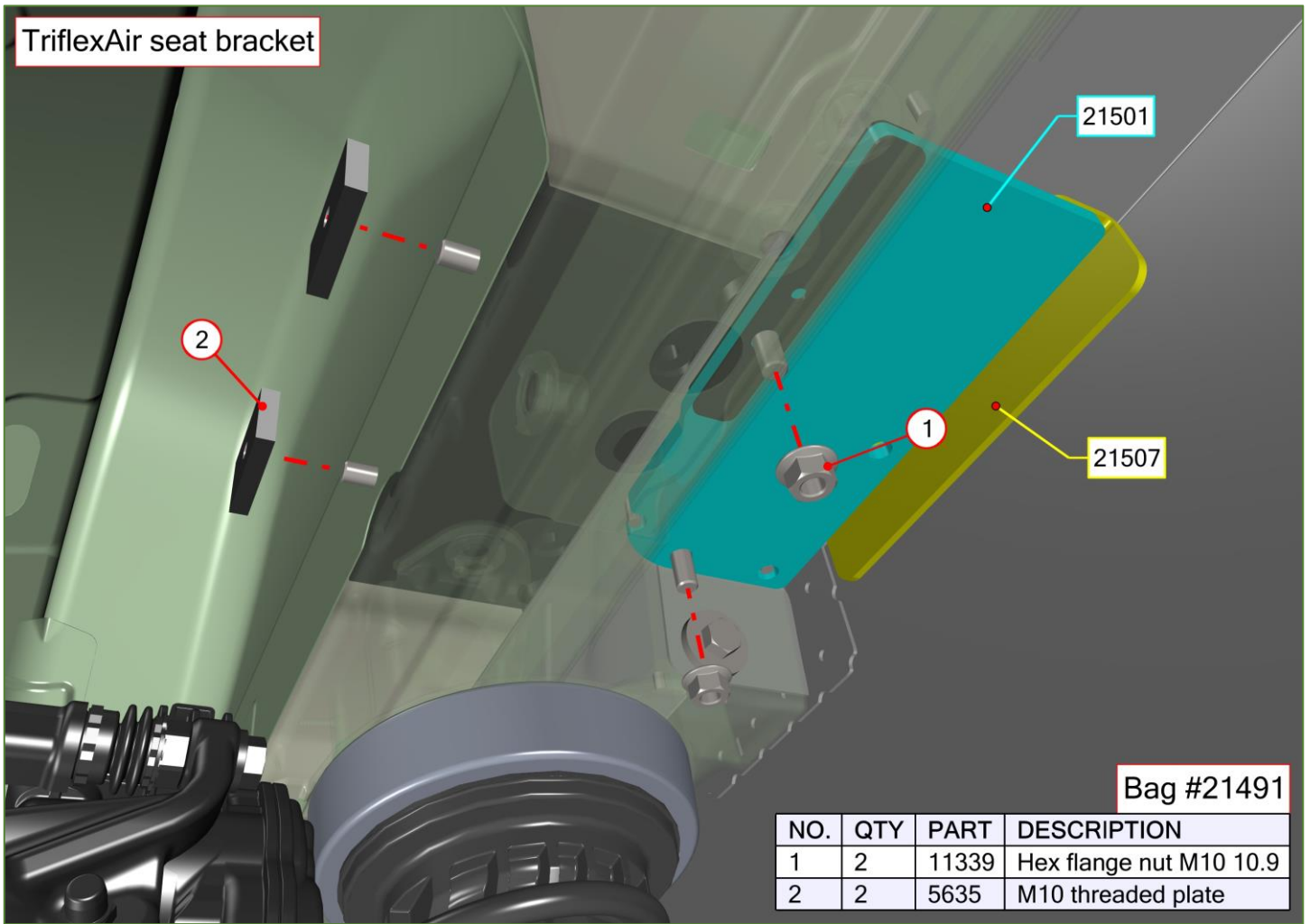

Bag #21491

NO.	QTY	PART	DESCRIPTION
1	2	11339	Hex flange nut M10 10.9
2	2	5635	M10 threaded plate

TriflexAir seat bracket

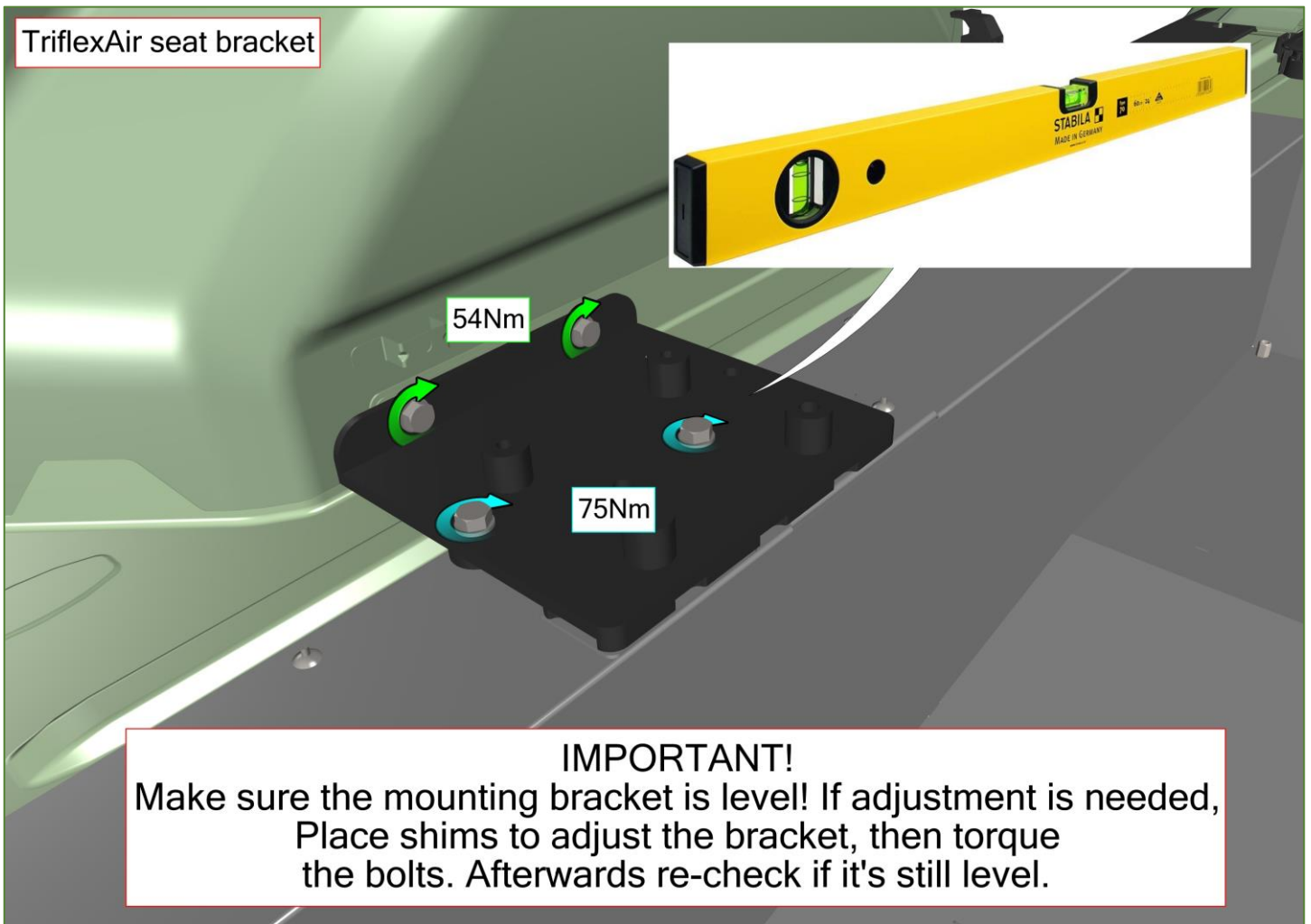

**IMPORTANT!**  
 Make sure the mounting bracket is level! If adjustment is needed, Place shims to adjust the bracket, then torque the bolts. Afterwards re-check if it's still level.

## Wiring

NO.	PART	DESCRIPTION
1	7454	Electric reels relais/wire loom
2	16487	Led lights relais/wire loom
3	16492	Led lights extension cable
4	16493	Led light
5	11594	Electric reels switch
6	3314	5 Amp fuse
7	95	10 Amp fuse

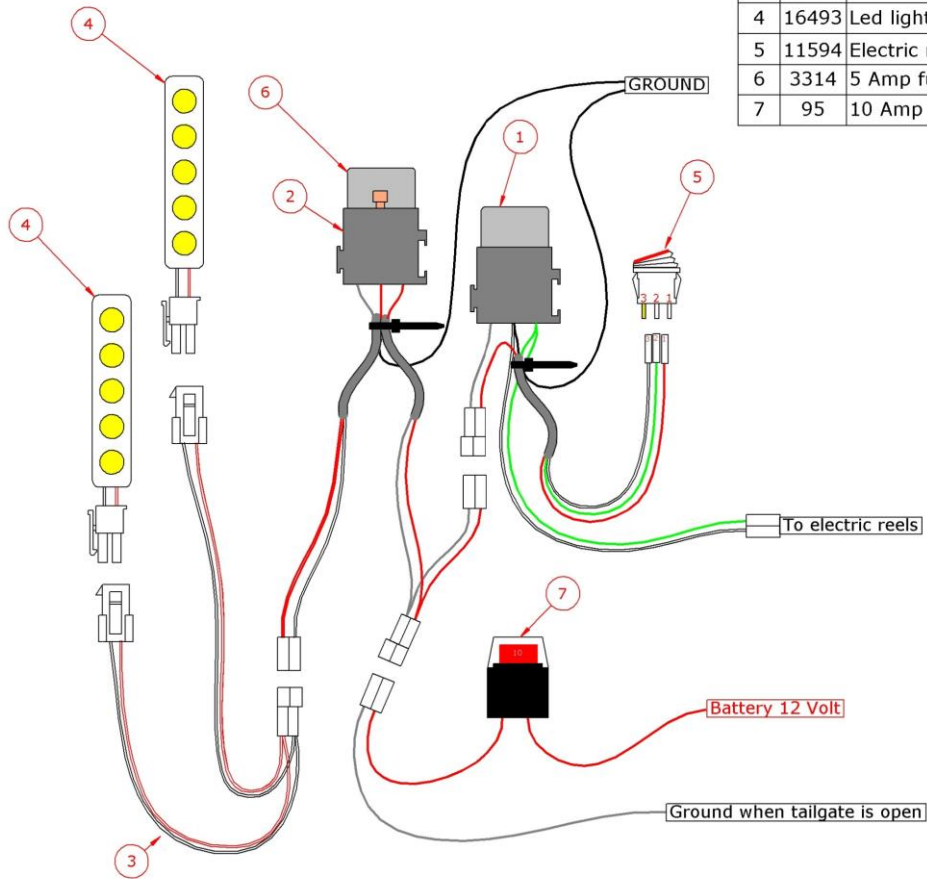

## Wiring

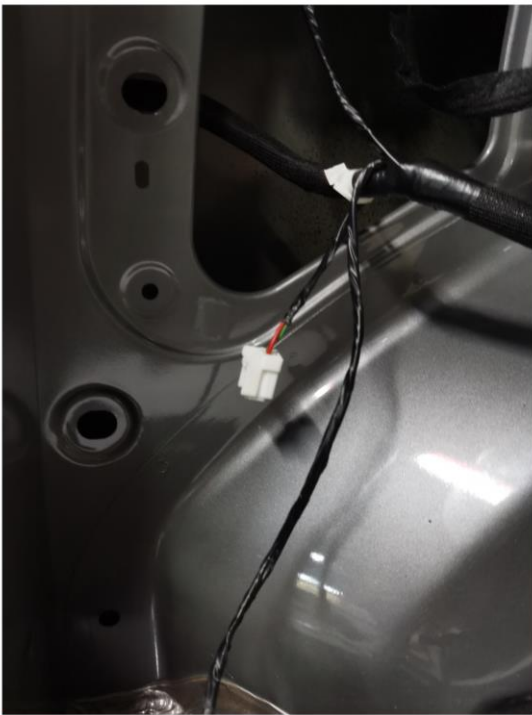

Connector with 12 poles

The trailer connector is located on the left side of the vehicle as shown. This is connected to fuse F28 in the fuse box on the driver side. This will be used to power the Tripod systems. Cut the red wire. Note: In some occasions there will be a different connector, one with 12 poles. This will be used in the same way.



Wiring

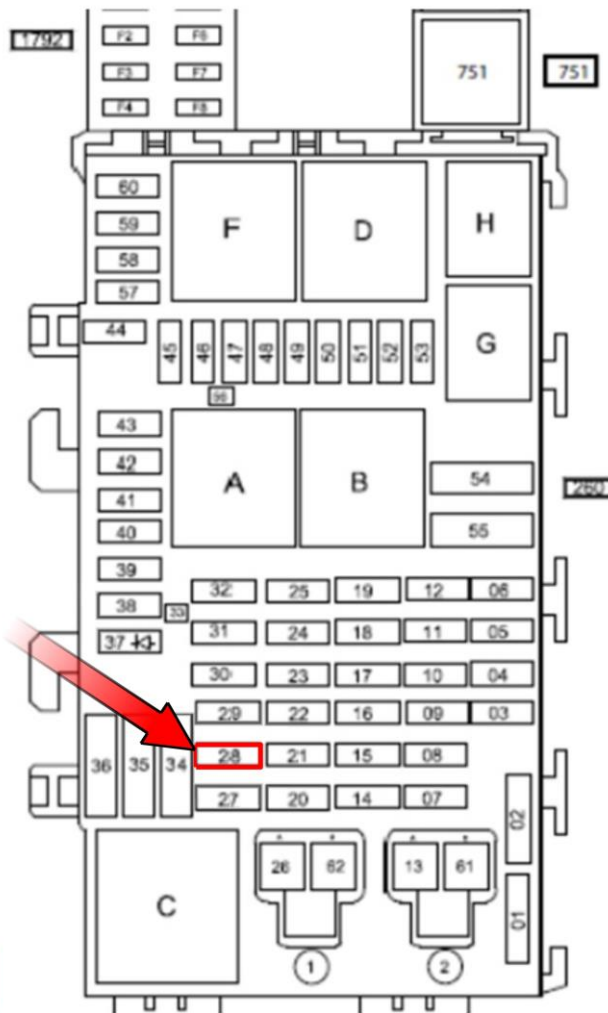

Fuse F28 is located here.

Wiring



Connect the Tripod supply wire where shown.





## Wiring



Position the relais in this area as far down as possible between the wheelarch and the D-pillar.

Mount the relais with the included screws as shown.

## Wiring



Connect the electric reel switch as shown. 1 of 3 pins on the switch is a different color. Make sure to connect the ground cable to that pin.

## Wiring

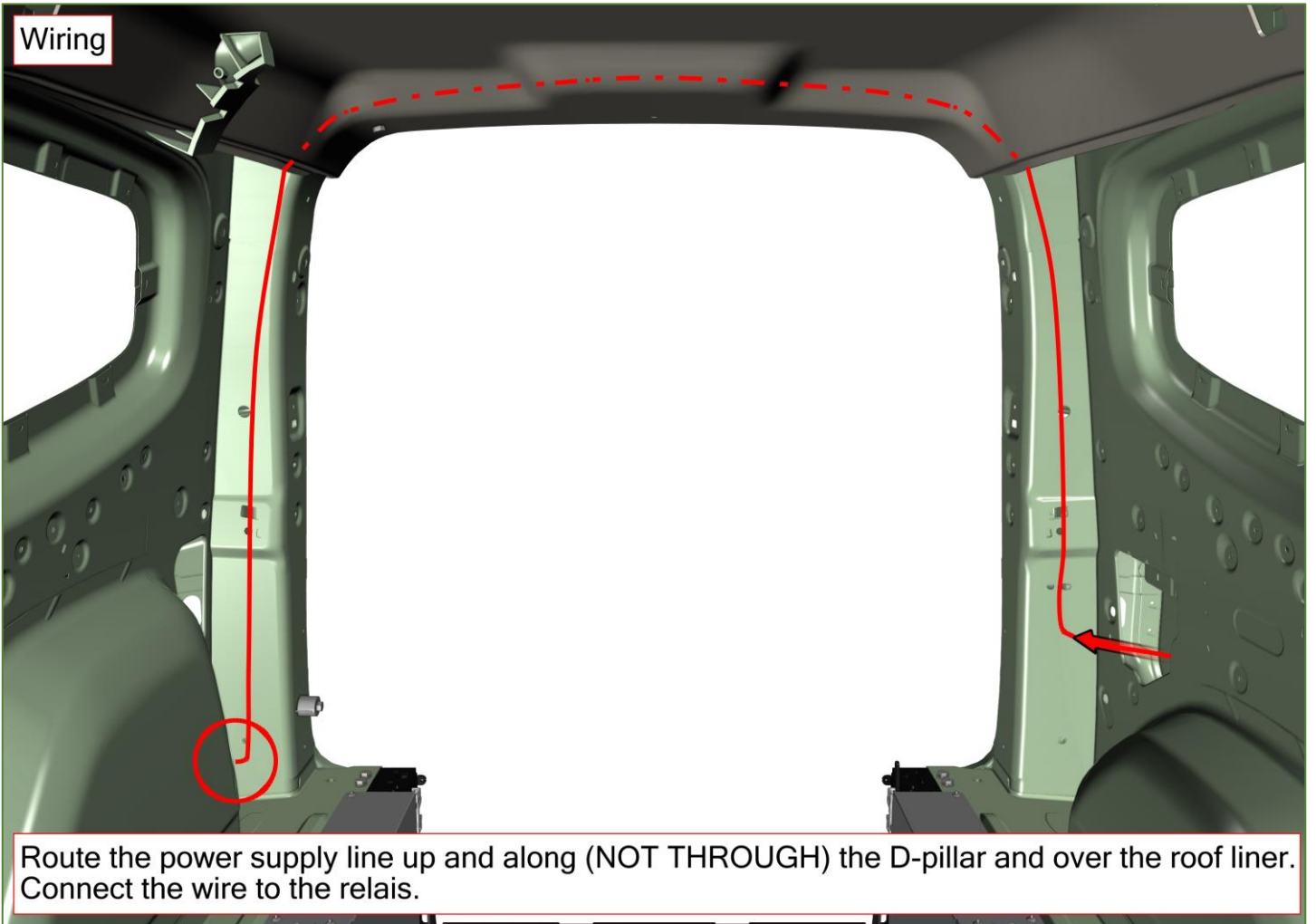

## Wiring

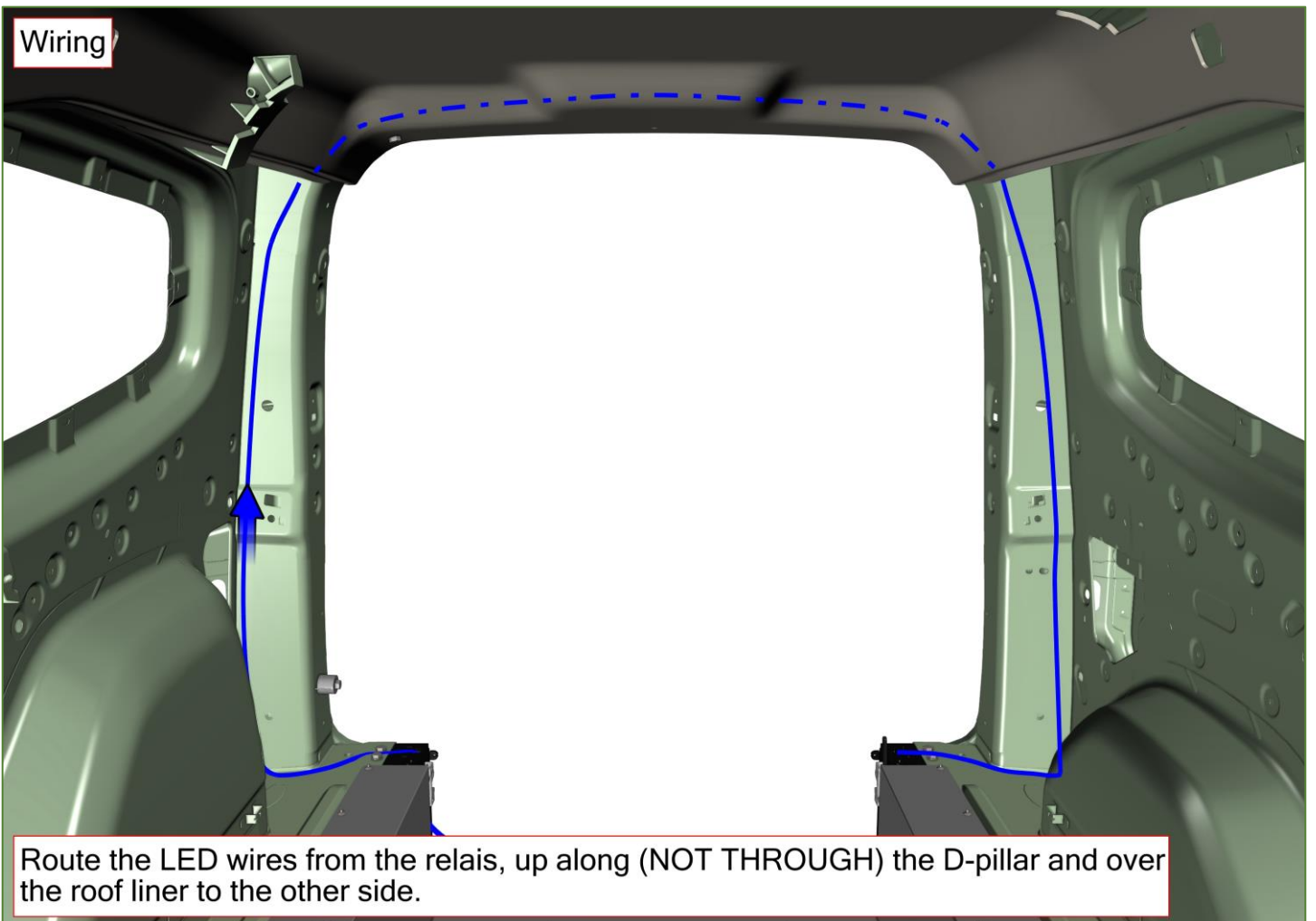

## Wiring

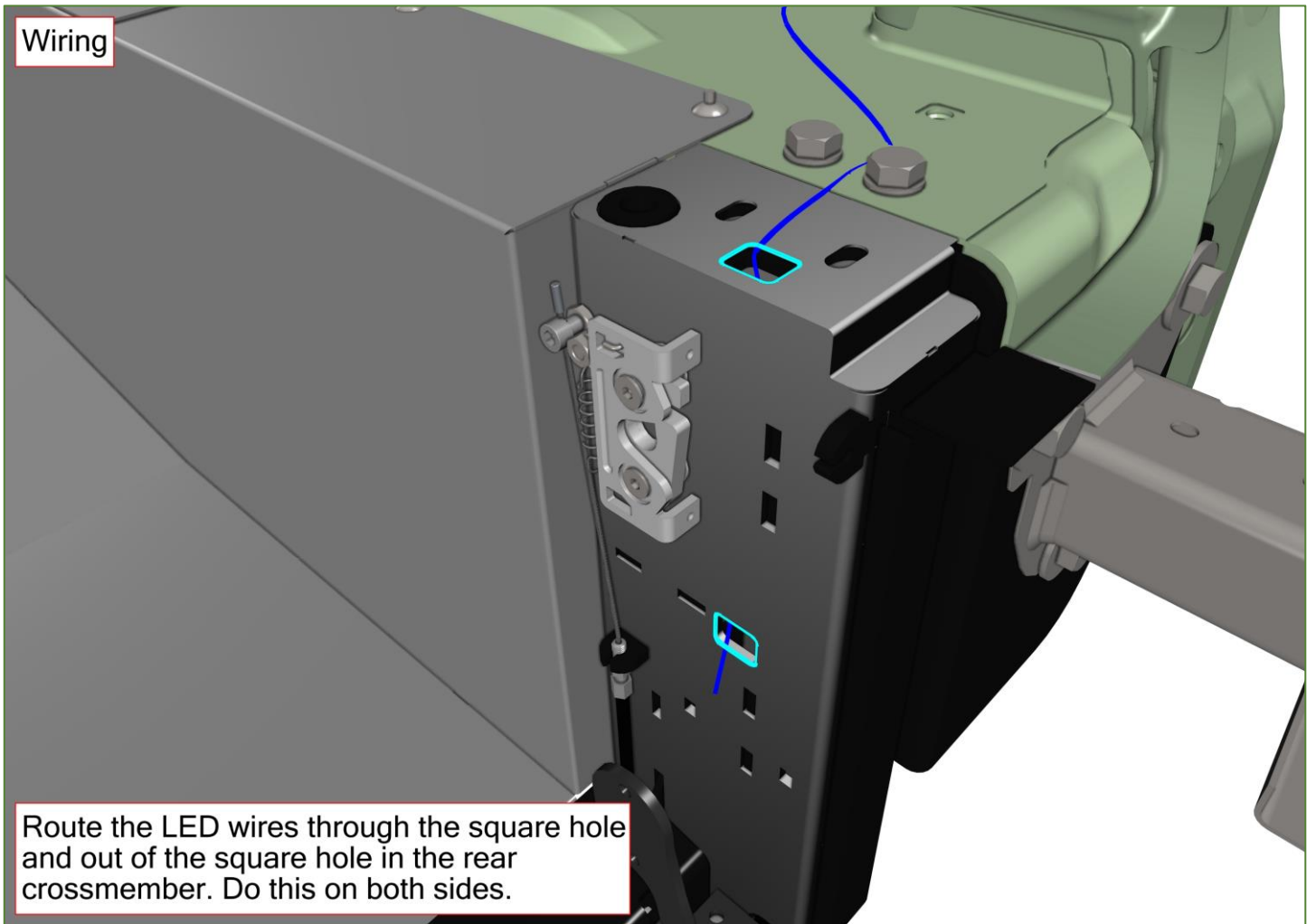

Route the LED wires through the square hole and out of the square hole in the rear crossmember. Do this on both sides.

## Wiring

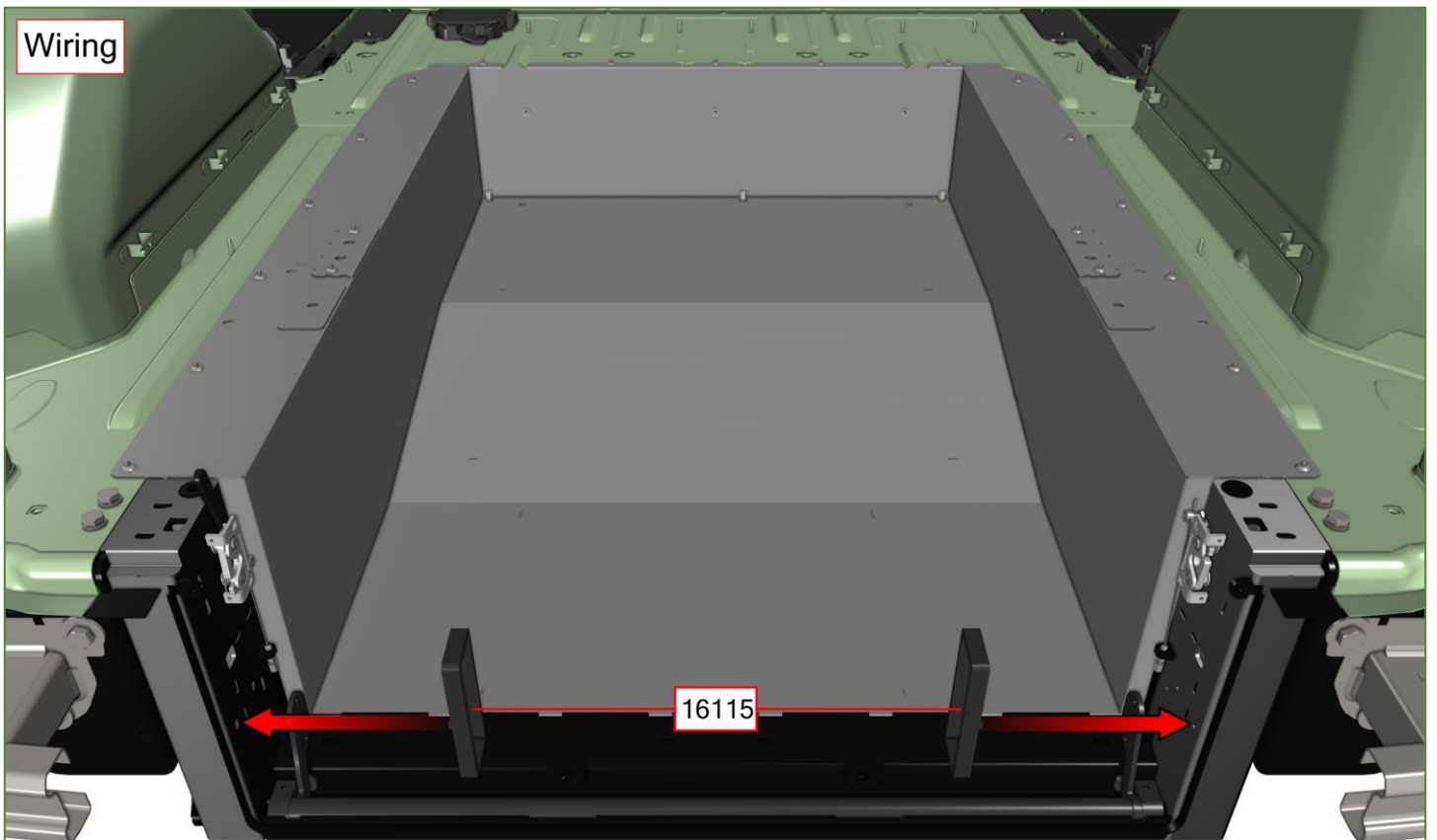

Apply cyanoacrylate glue (super/instant glue) to the back of the led housing and fix them to the crossmember using the square holes to position correctly.



Wiring

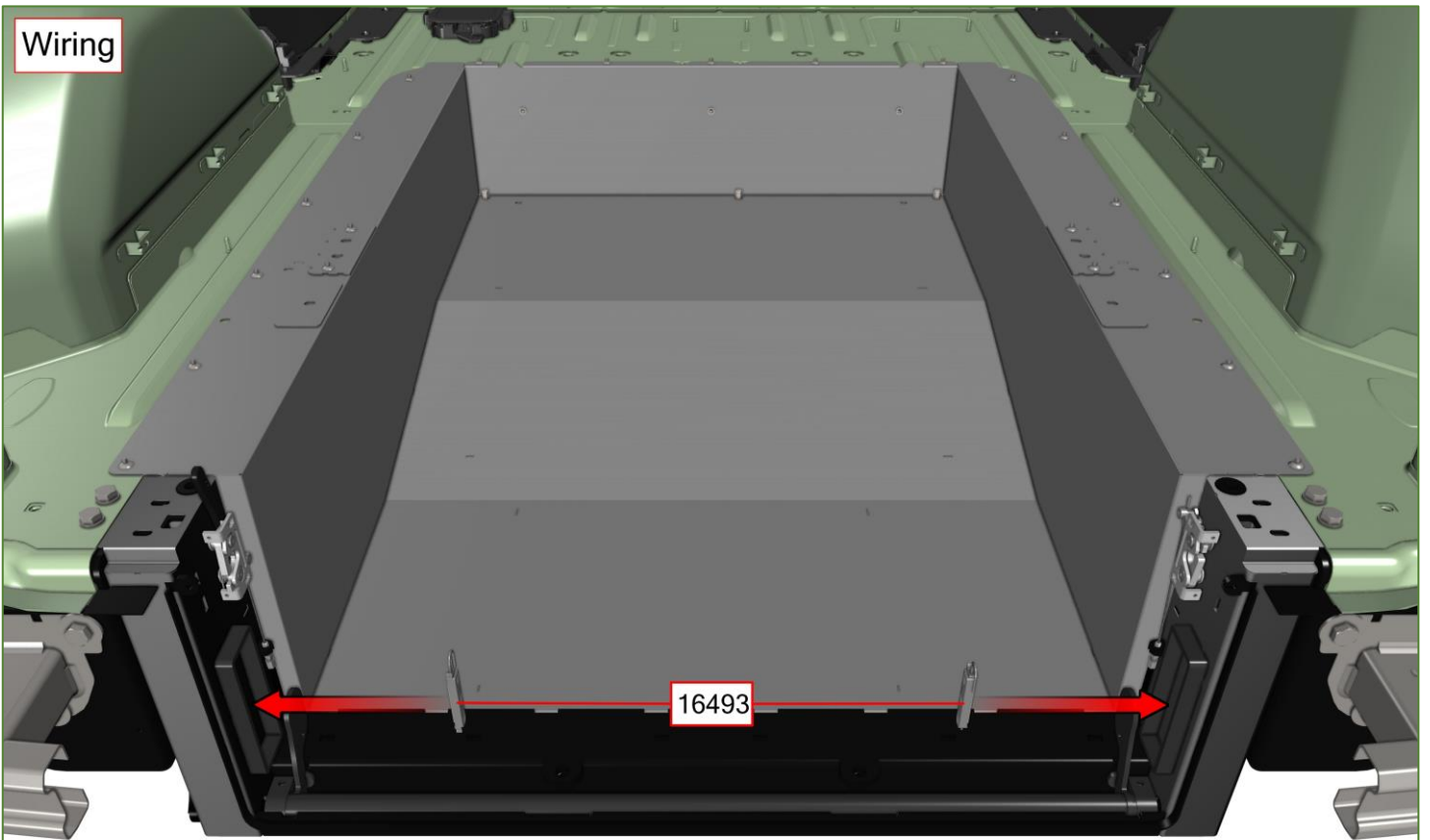

Pull the foil from the back of the led lights and position them centered in the housing on the crossmember.

Wiring

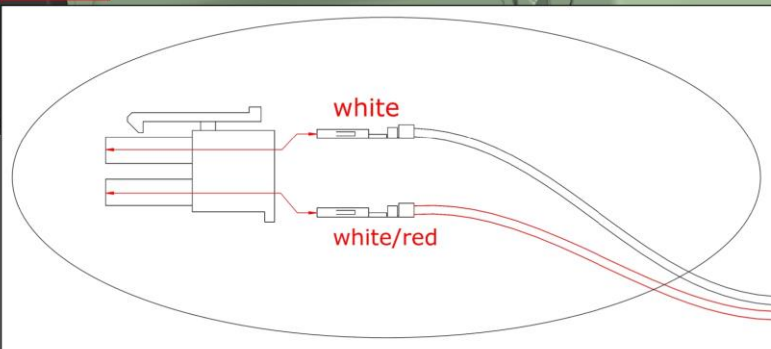

Connect the wires as shown.

## Wiring

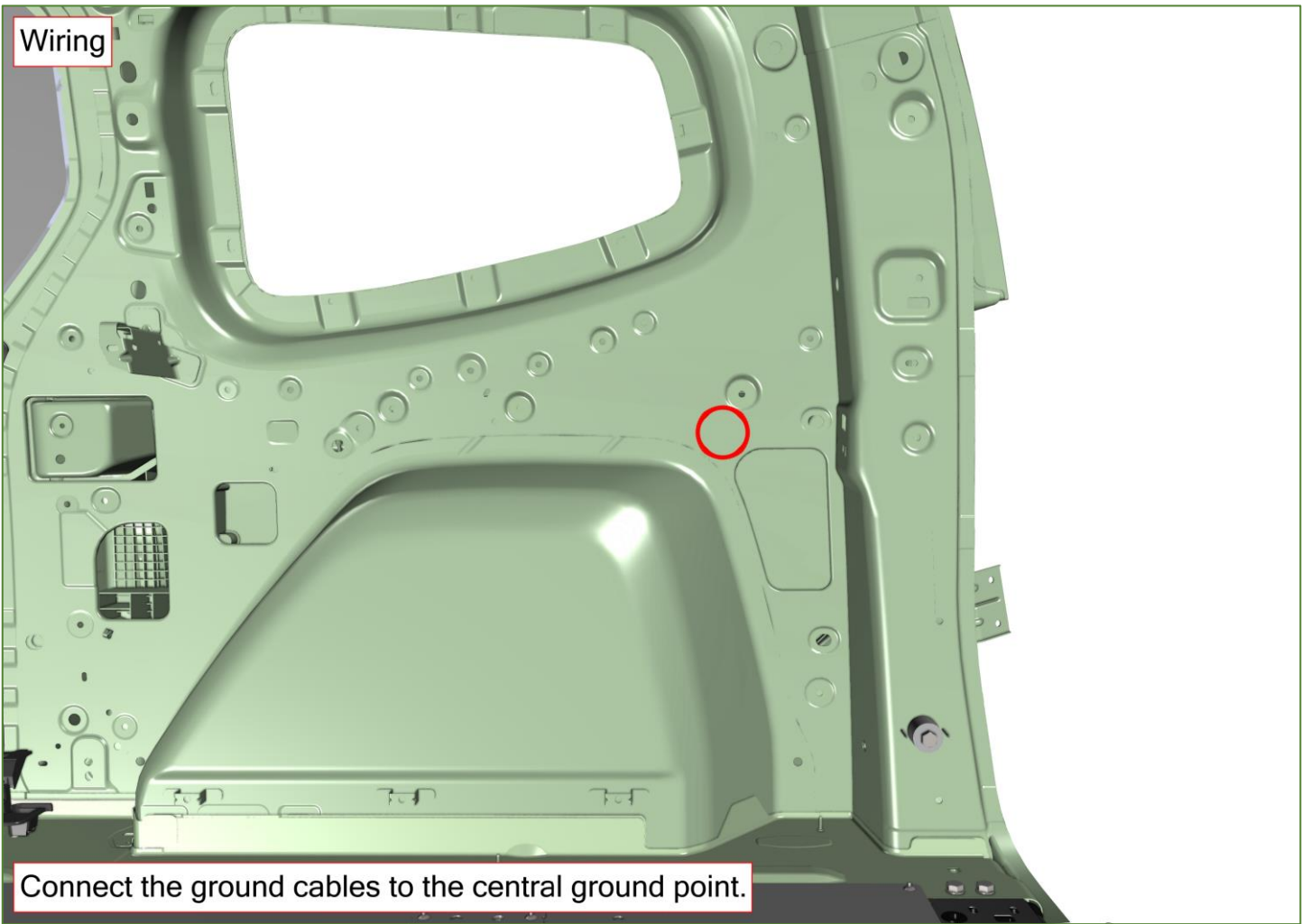

Connect the ground cables to the central ground point.

## Wiring

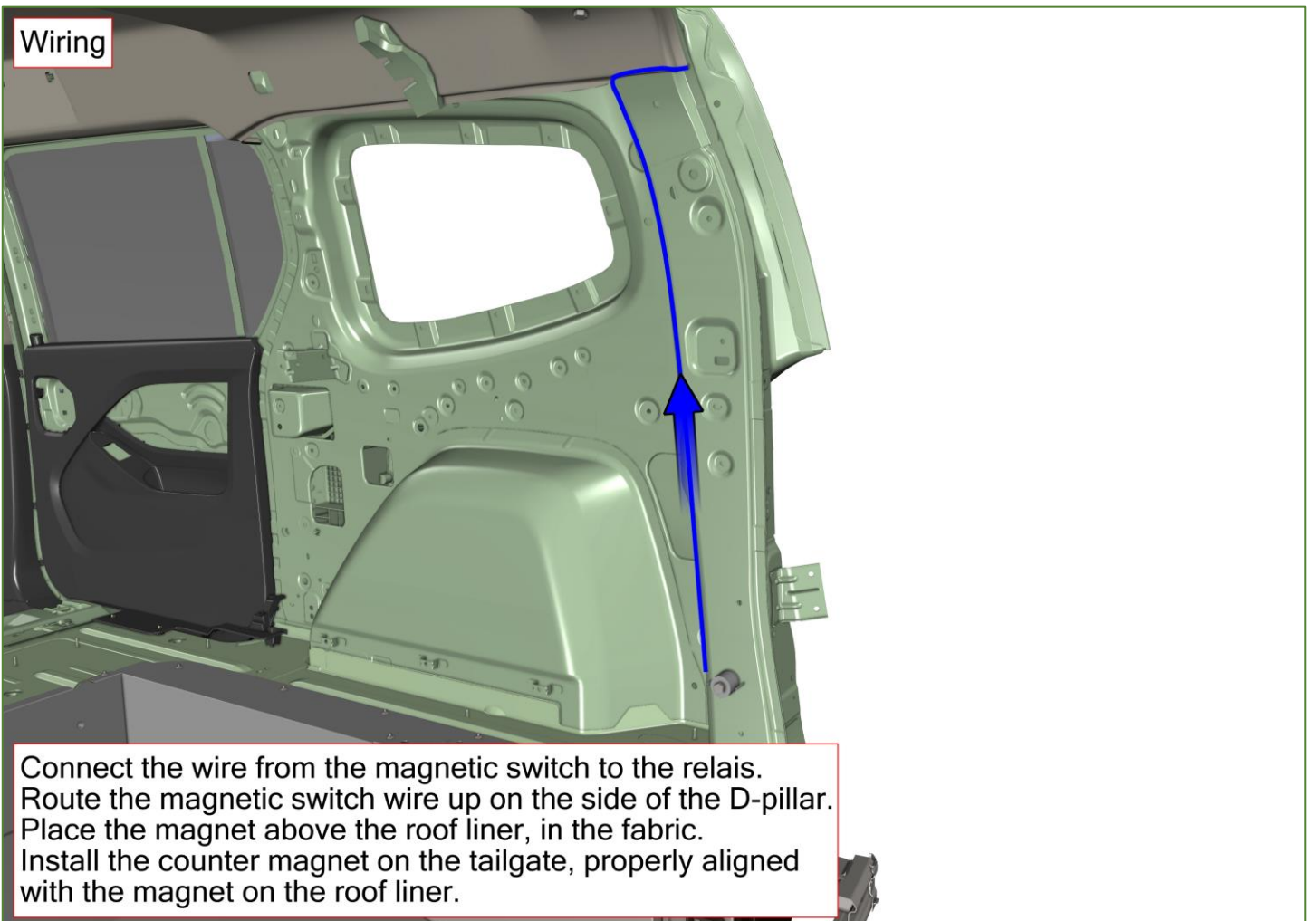

Connect the wire from the magnetic switch to the relays.  
Route the magnetic switch wire up on the side of the D-pillar.  
Place the magnet above the roof liner, in the fabric.  
Install the counter magnet on the tailgate, properly aligned  
with the magnet on the roof liner.

## Wiring



Apply the connectors to both ends as shown.

Route the front wires over the wheelarch as shown.  
Place the connectors already in the right position for the retractors.

## Floor LED preparation

In case of the floor LED lights. Remove the marked strips from the floor.



Floor LED preparation

Route the wires up against the D-pillar. Not through.

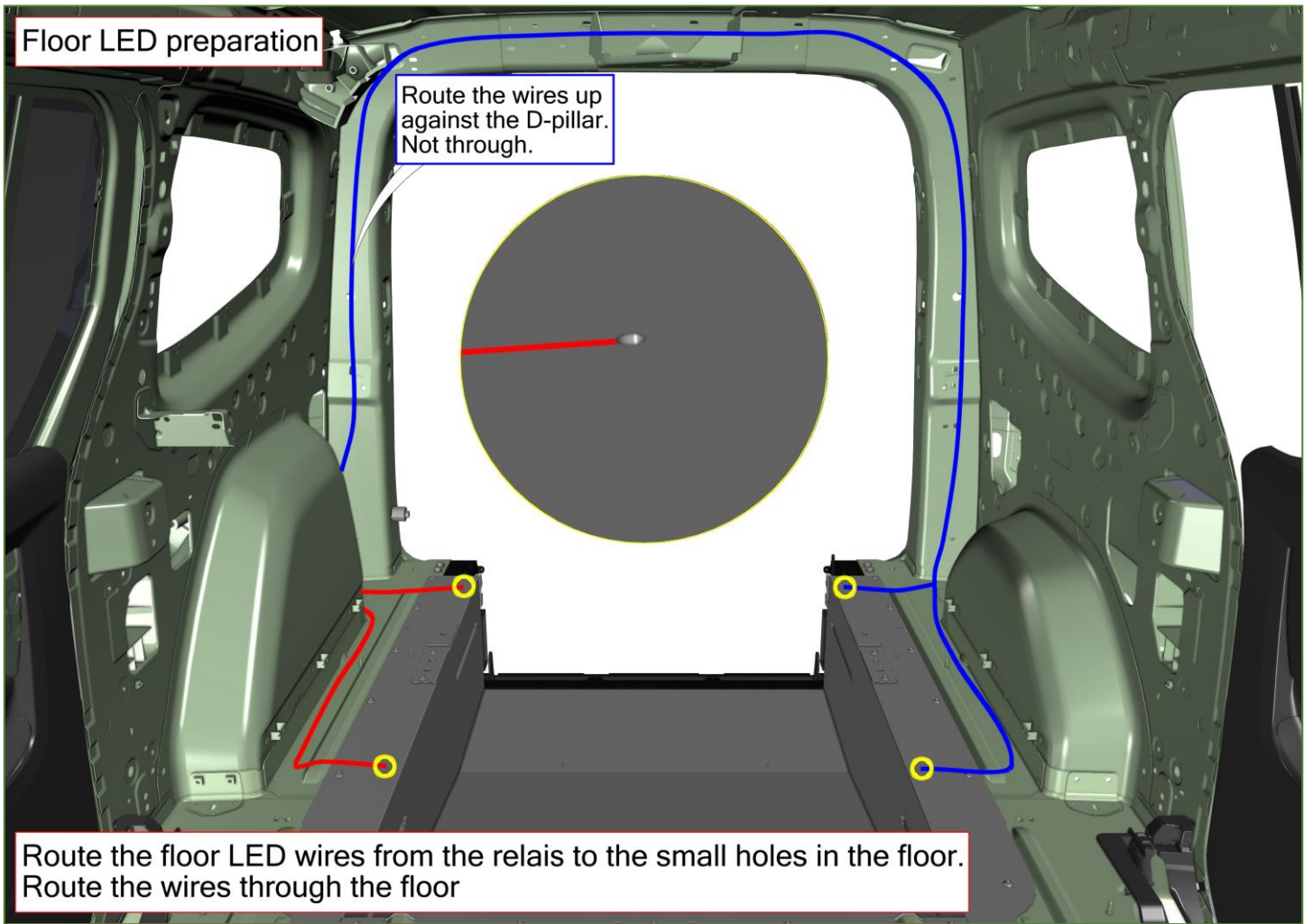

Floor LED preparation

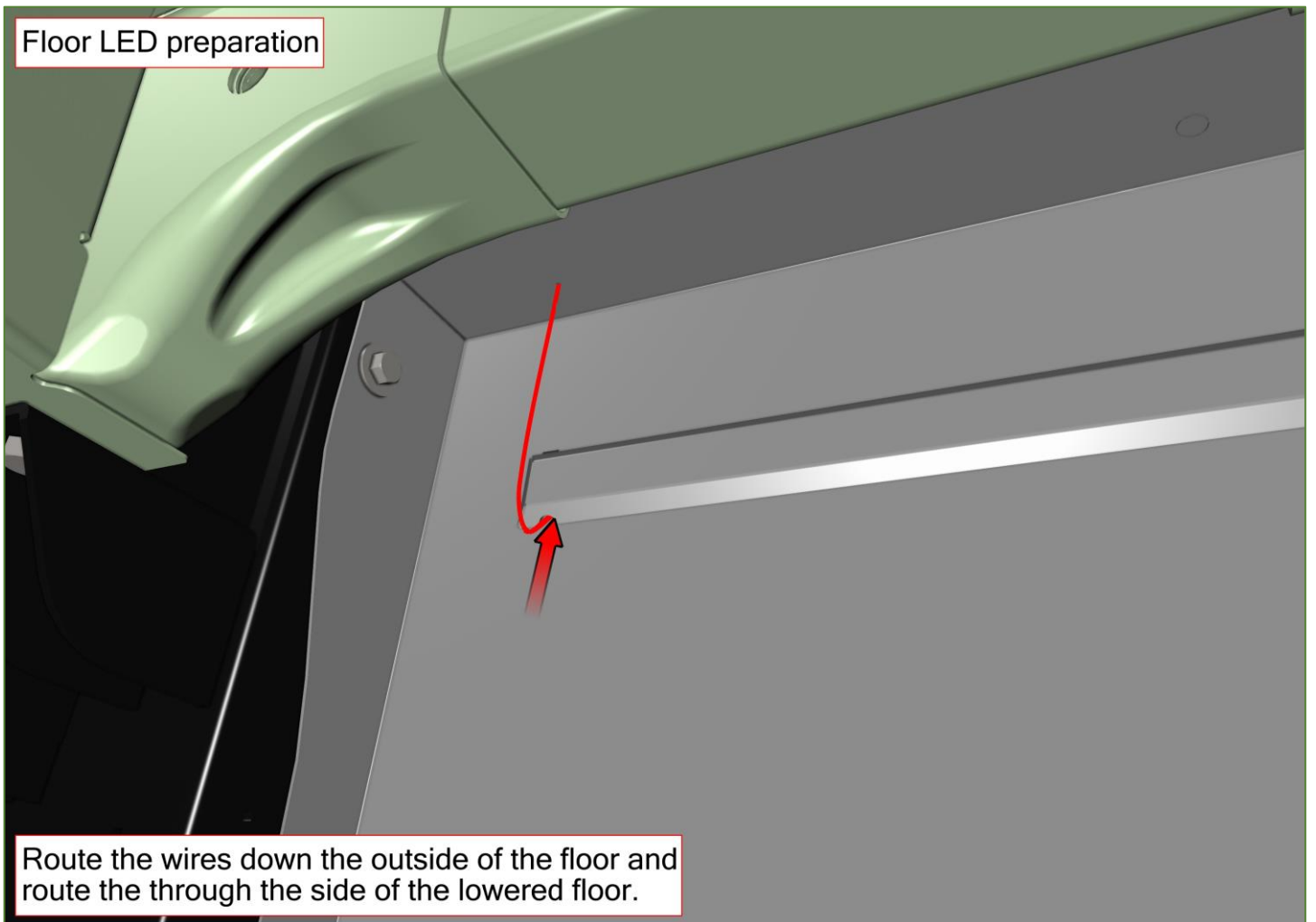

Floor LED preparation

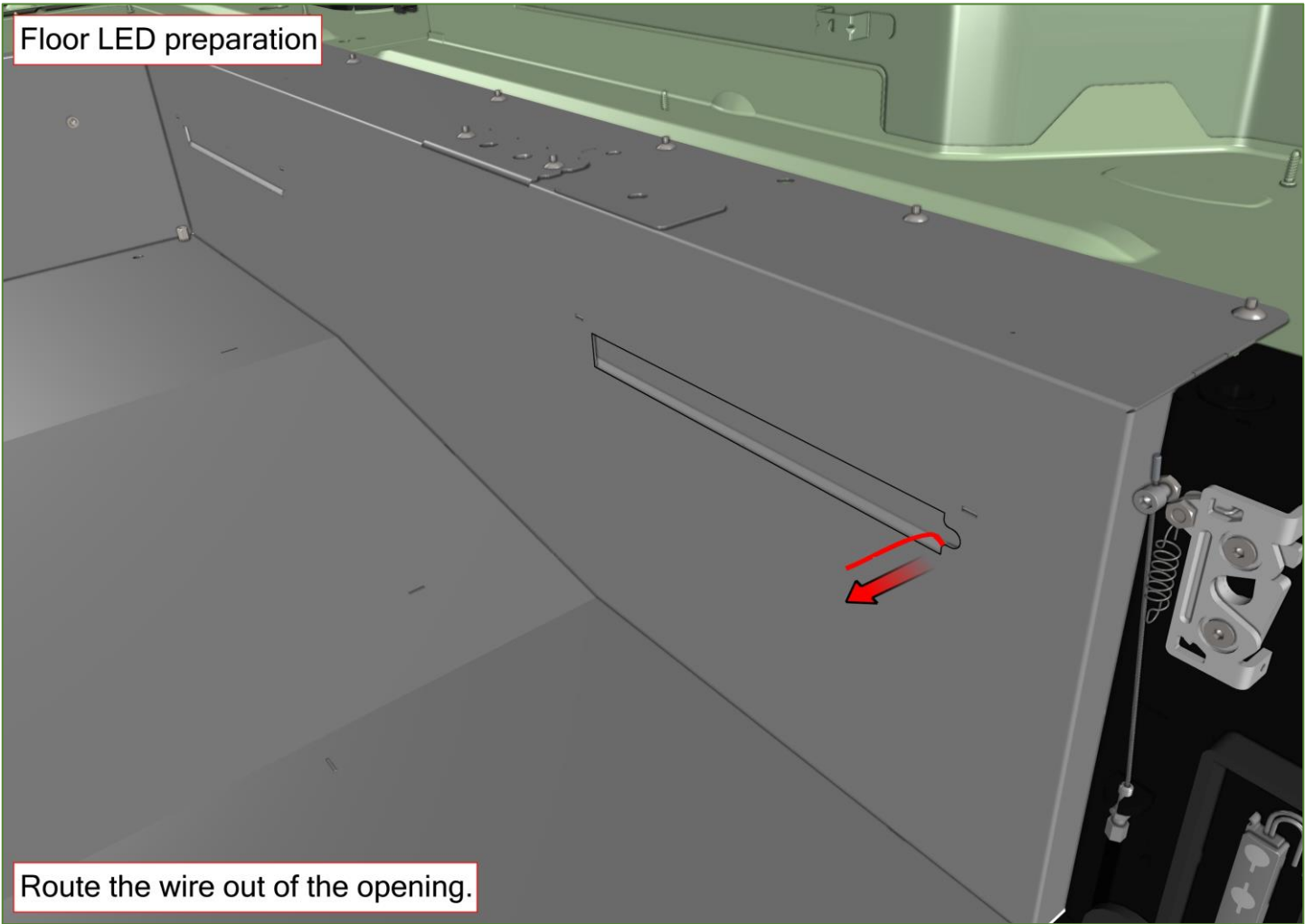

Route the wire out of the opening.

Fuel system install

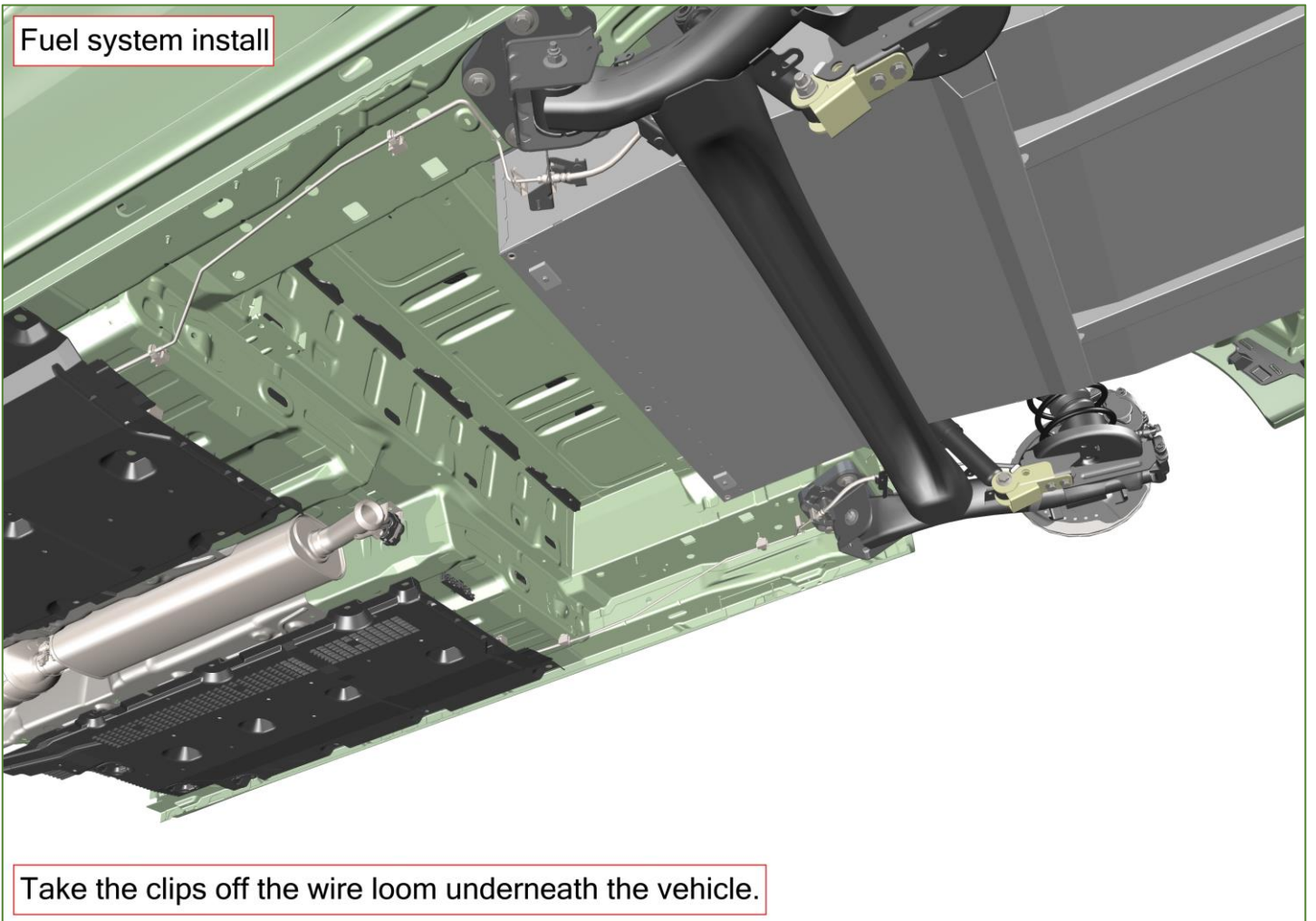

Take the clips off the wire loom underneath the vehicle.

## Fuel system install

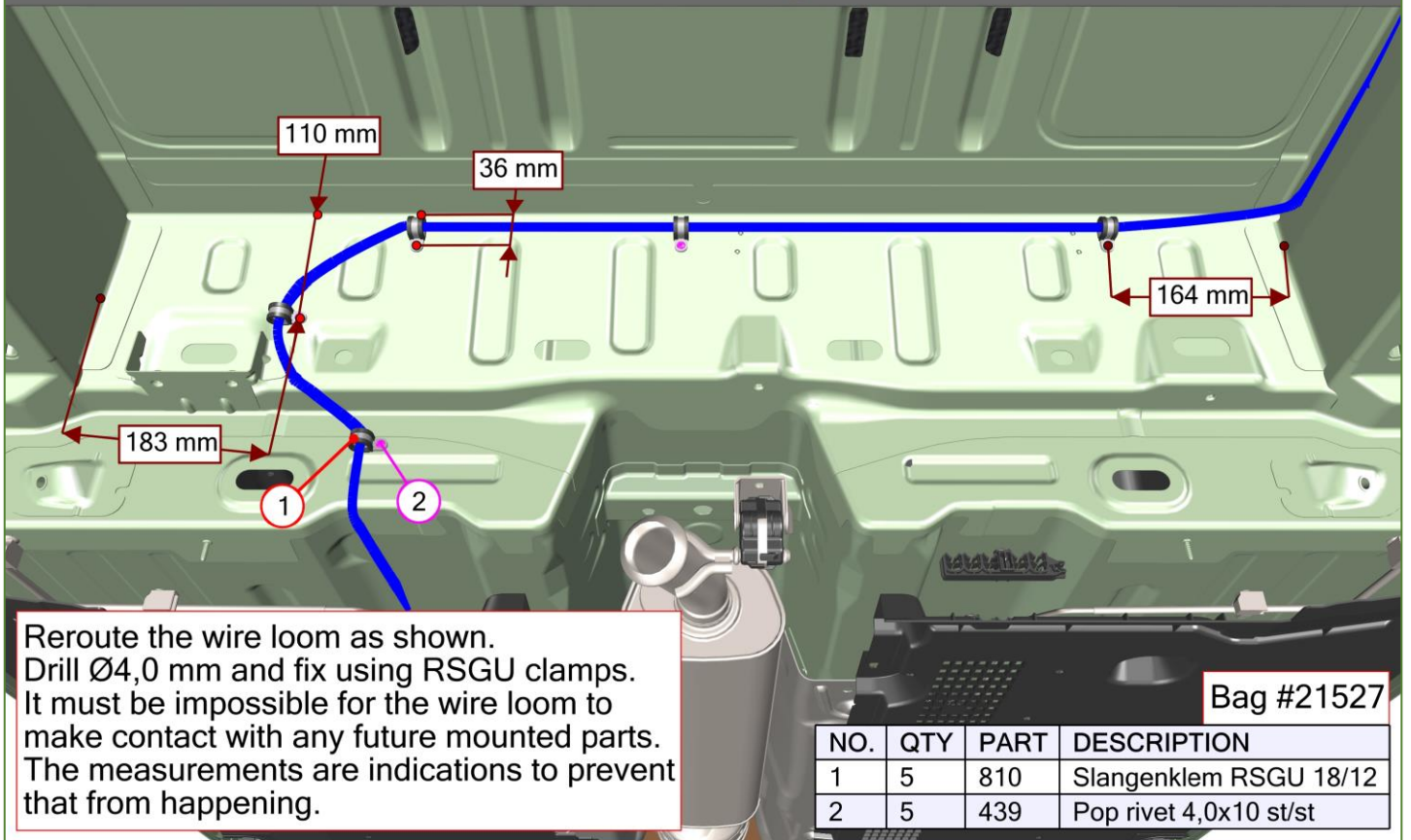

## Fuel system install

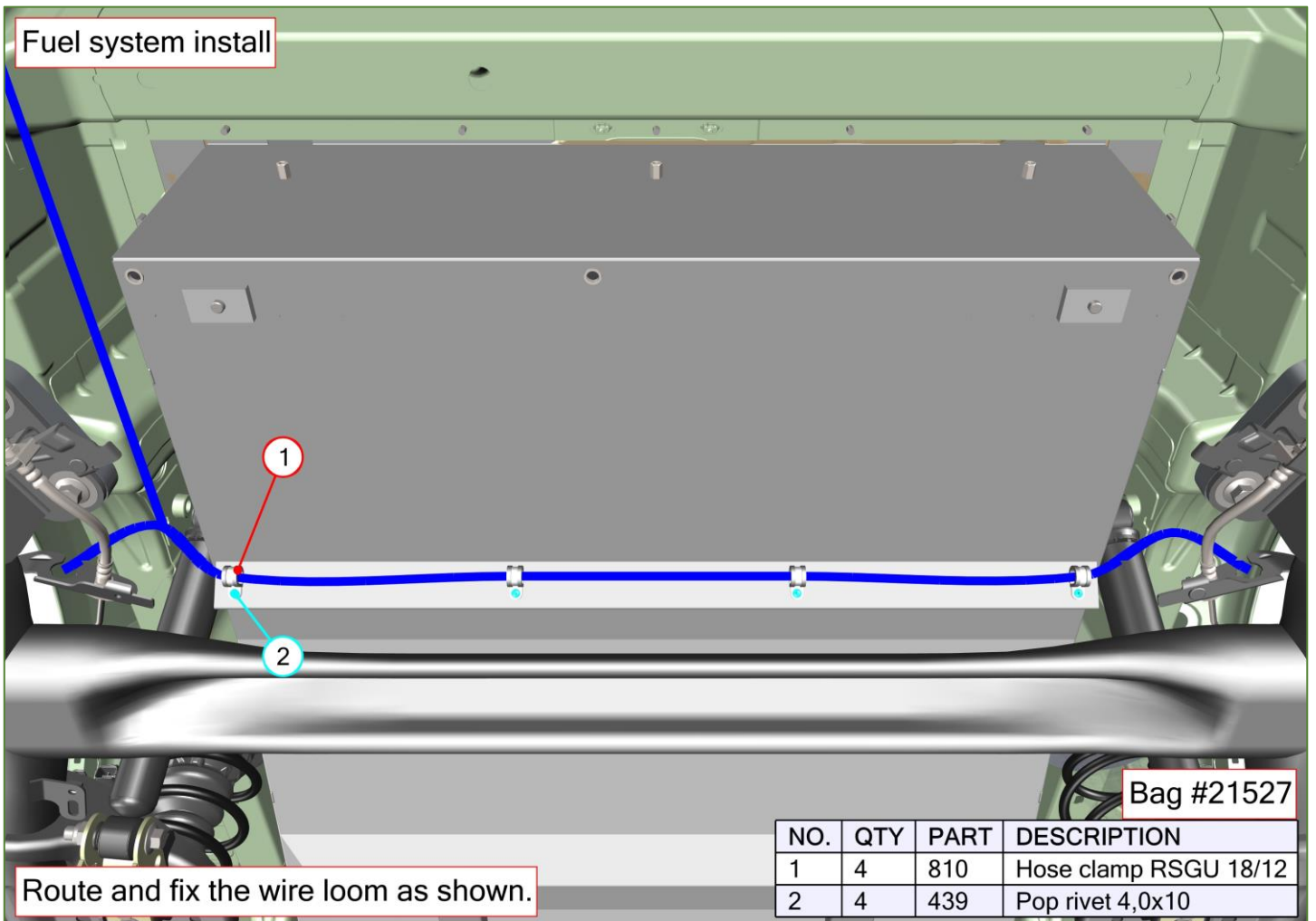



Fuel system install

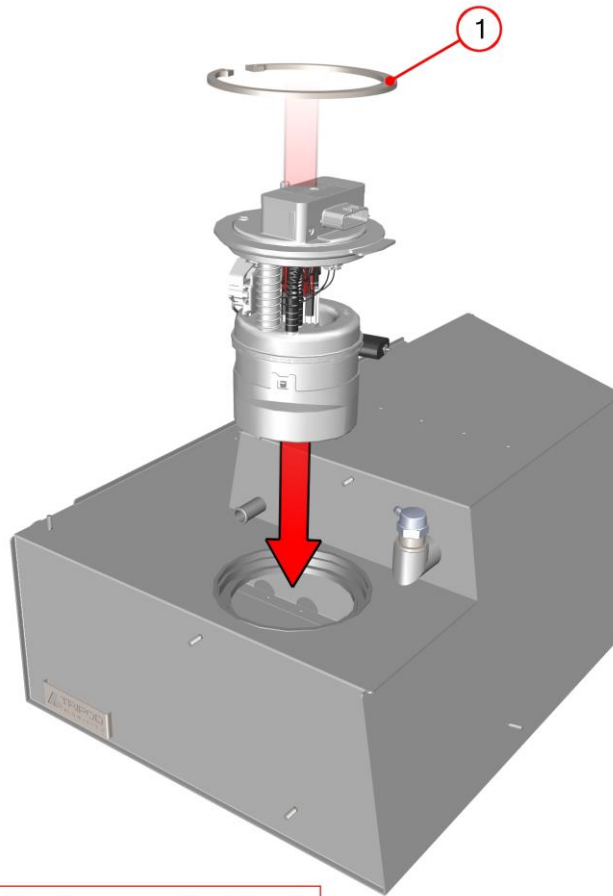

Install the fuel element inside the new fuel tank.  
Use the OEM O-ring.

Fuel system install

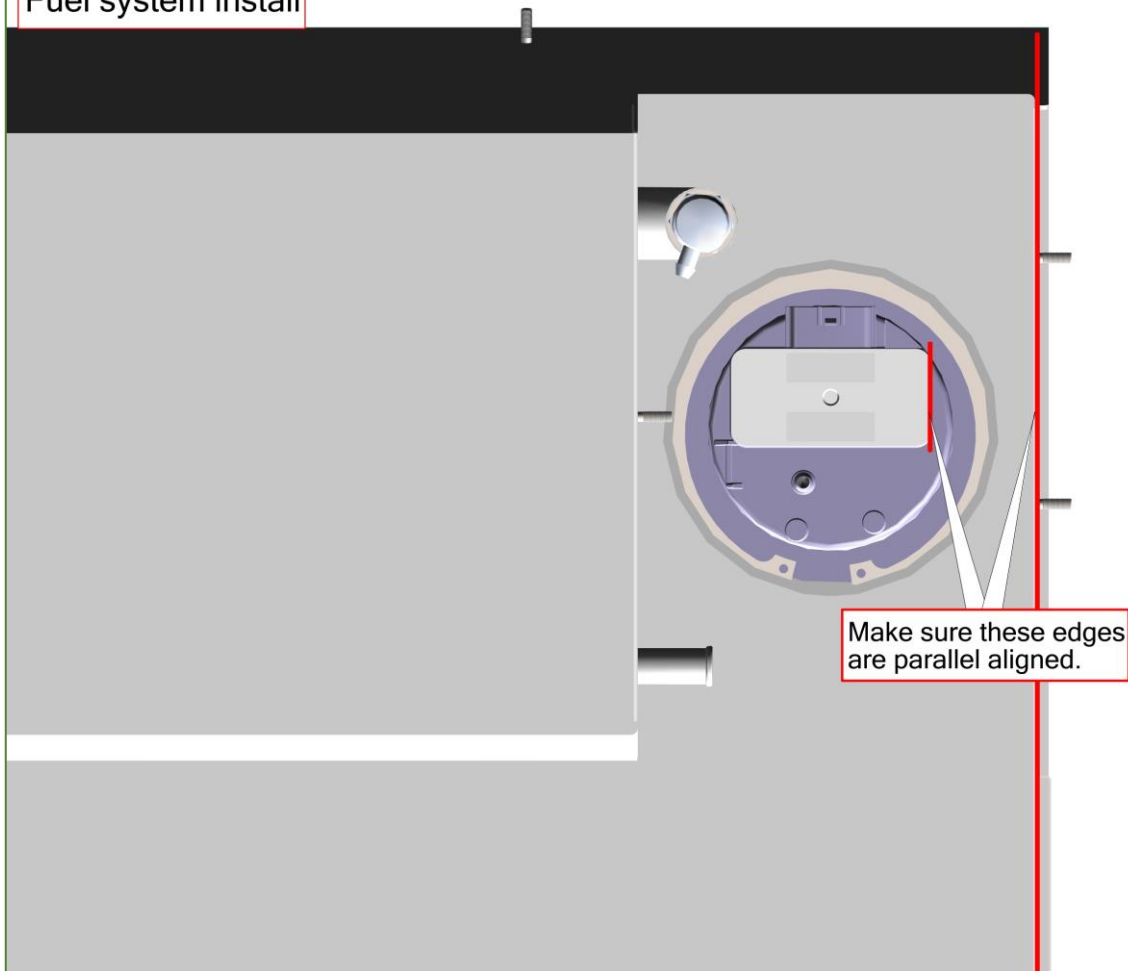

Make sure these edges  
are parallel aligned.

Fuel system install

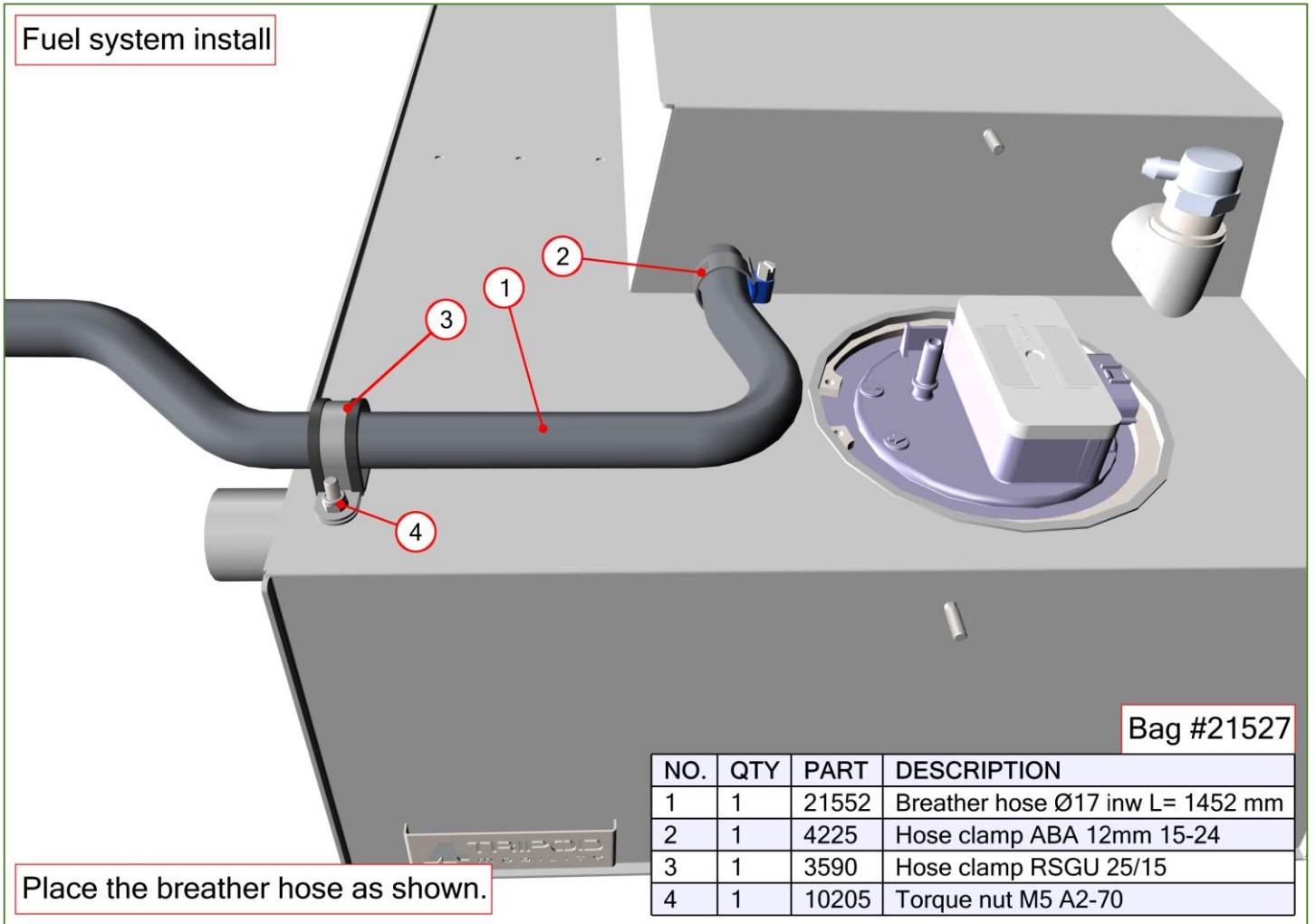

Bag #21527

NO.	QTY	PART	DESCRIPTION
1	1	21552	Breather hose Ø17 inw L= 1452 mm
2	1	4225	Hose clamp ABA 12mm 15-24
3	1	3590	Hose clamp RSGU 25/15
4	1	10205	Torque nut M5 A2-70

Place the breather hose as shown.

Fuel system install

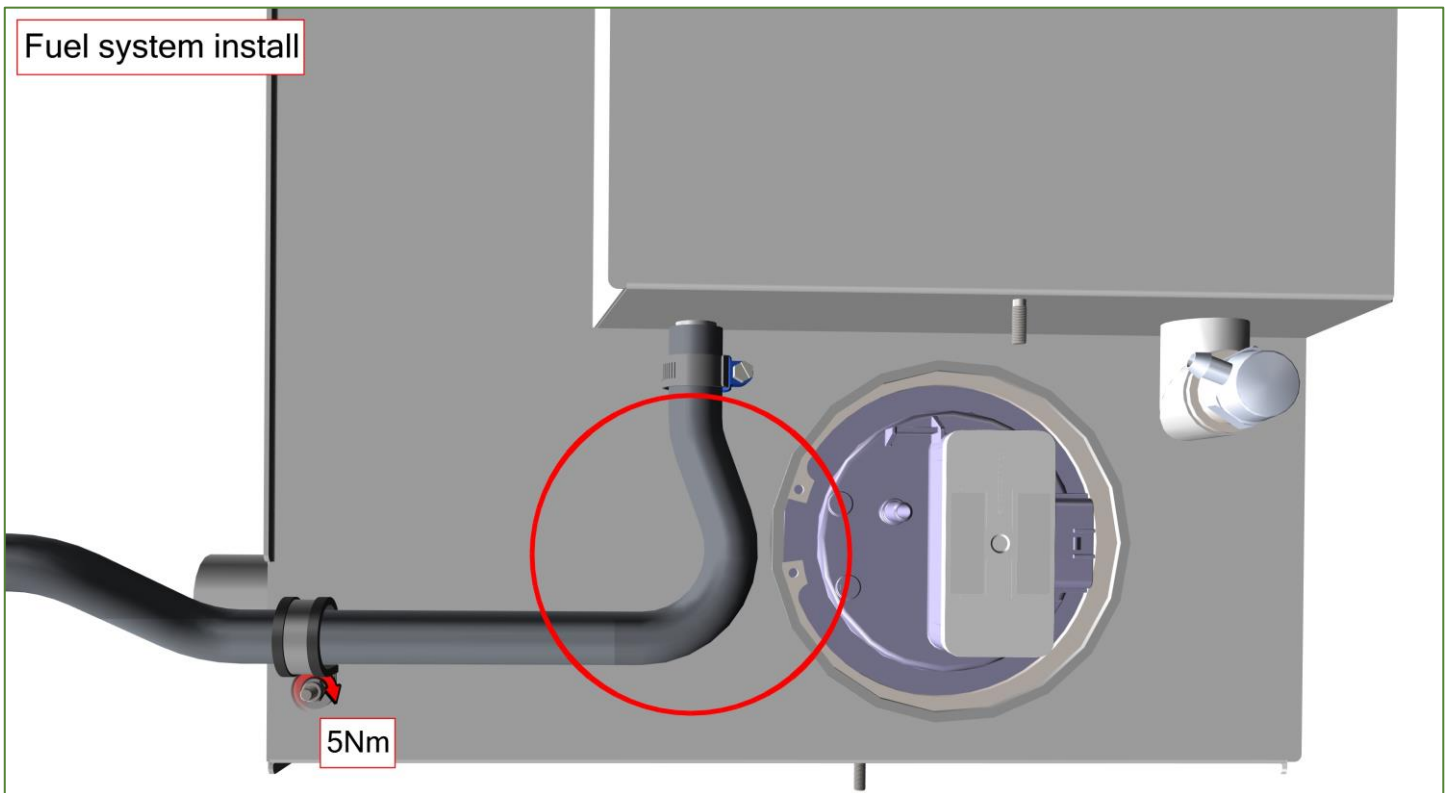

5Nm

Make sure the turn in the hose is as shown. This hose must not get stuck between the chassis and the tank while mounting.

Fuel system install

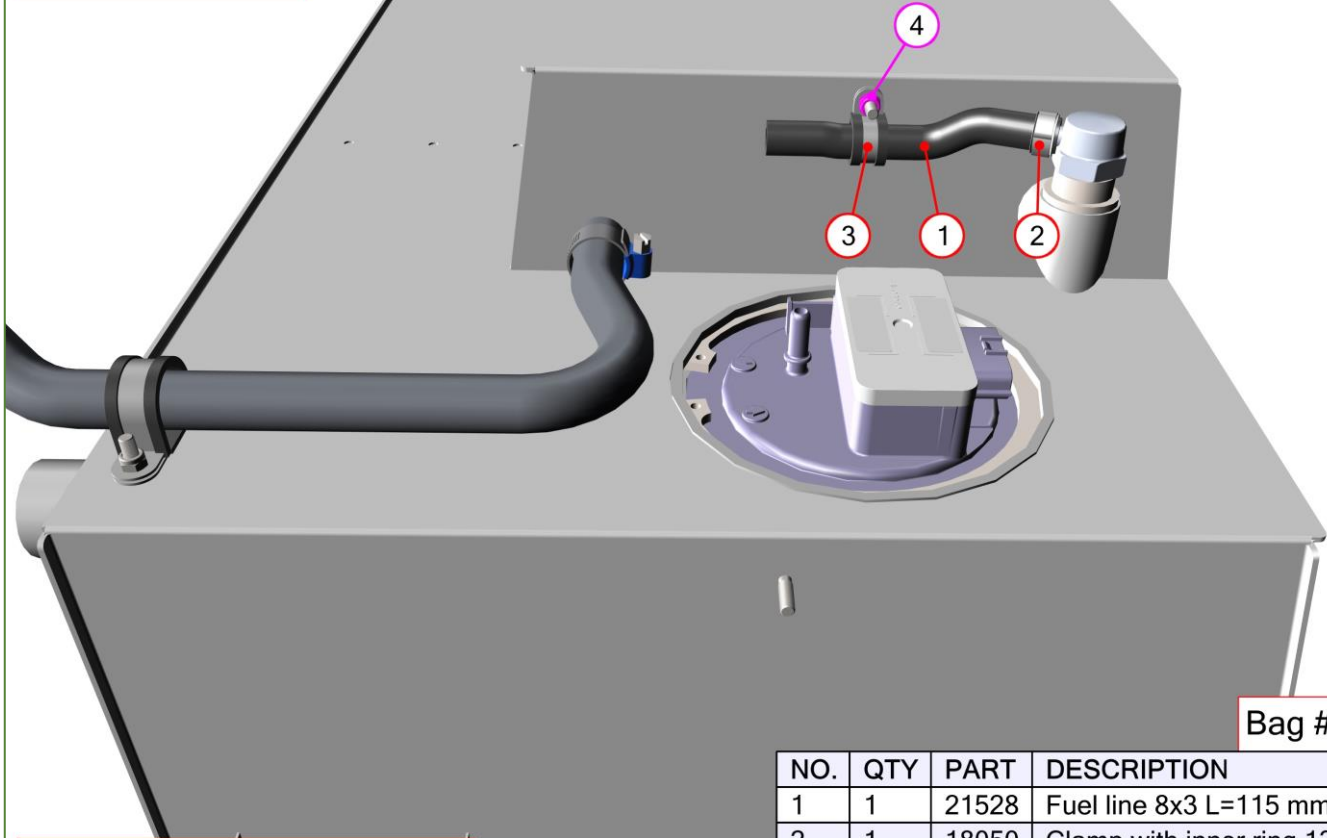

Bag #21527

NO.	QTY	PART	DESCRIPTION
1	1	21528	Fuel line 8x3 L=115 mm
2	1	18050	Clamp with inner ring 13,0-15,3
3	1	3545	Hose clamp RSGU 12/15
4	1	10205	Torque nut M5 A2-70

Install the small EVAP conduit on the small nipple as shown.

Fuel system install

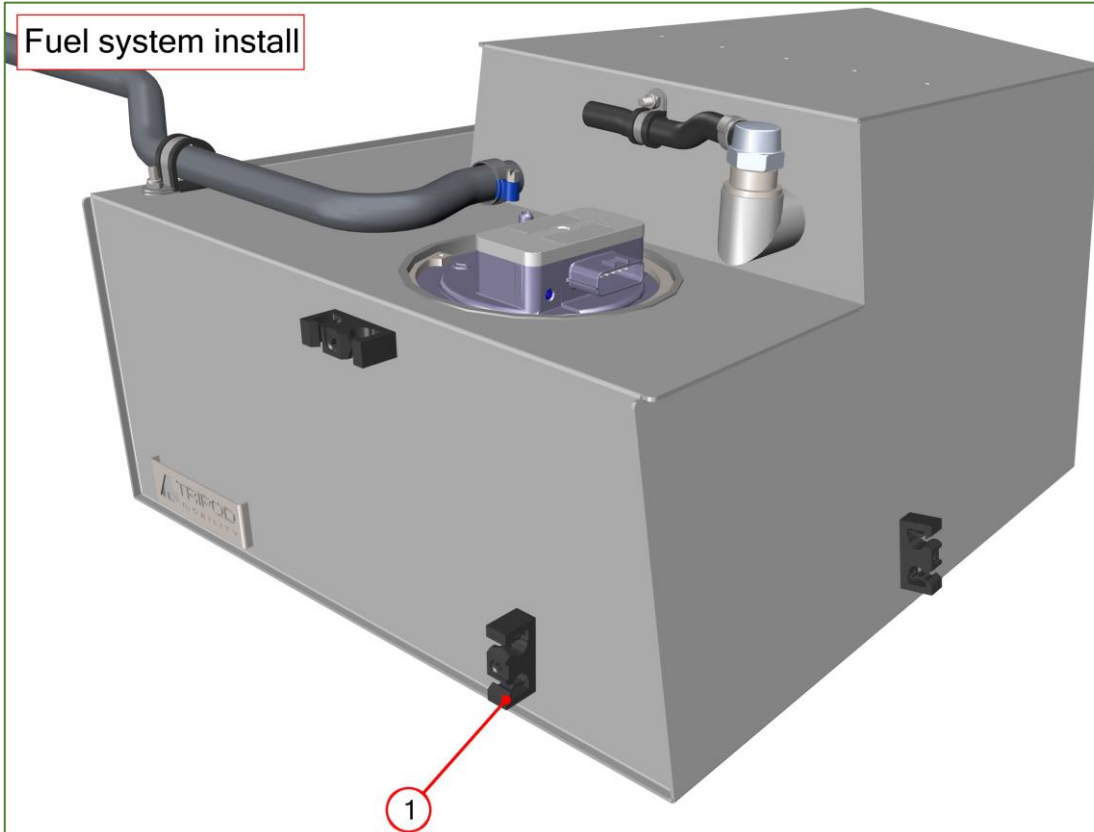

Bag #21527

NO.	QTY	PART	DESCRIPTION
1	3	21554	Flue line clamp Ø8-10 mm

Place the fuel line clamps on the threaded studs.



Fuel system install

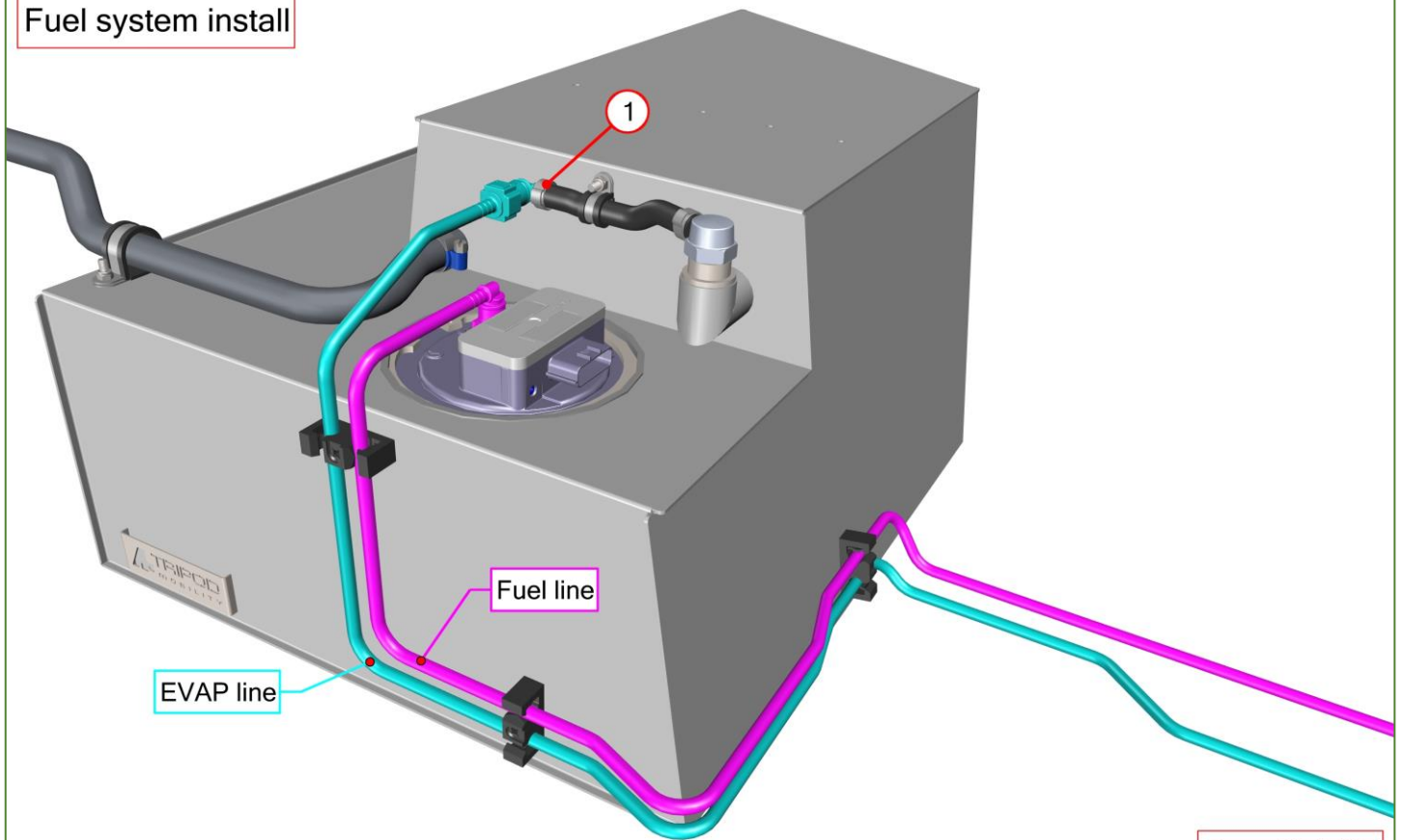

Bag #21527

Install the EVAP and fuel line as shown.

NO.	QTY	PART	DESCRIPTION
1	1	18050	Clamp with inner ring 13,0-15,3

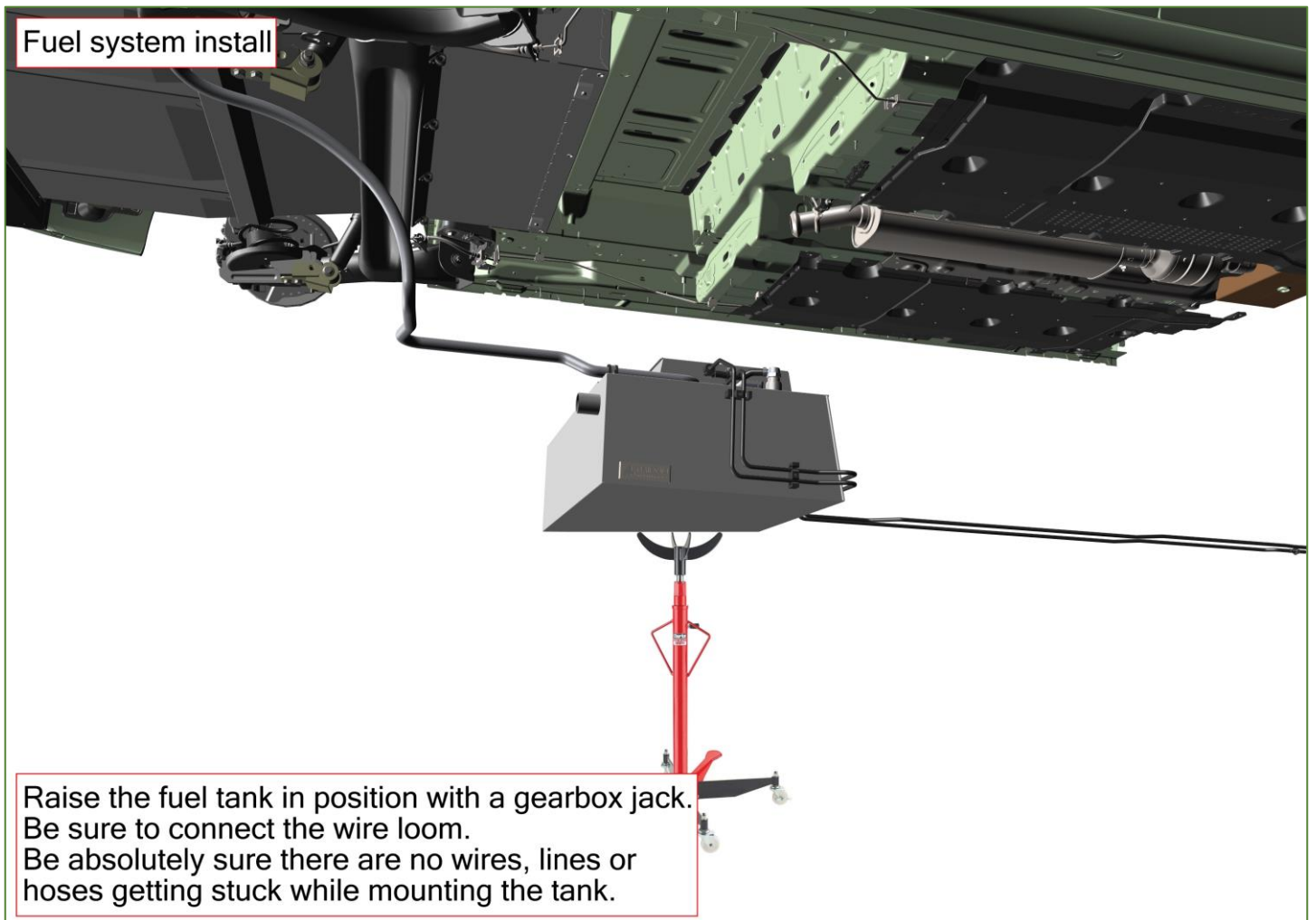

Fuel system install

Raise the fuel tank in position with a gearbox jack. Be sure to connect the wire loom. Be absolutely sure there are no wires, lines or hoses getting stuck while mounting the tank.

Fuel system install

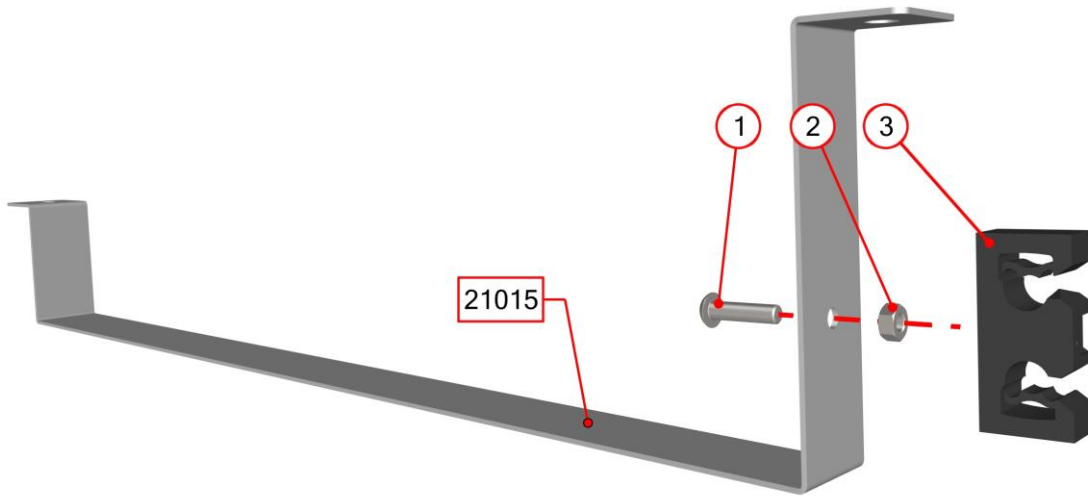

Bag #21527

Install a fuel line clamp on the fuel tank bracket.

NO.	QTY	PART	DESCRIPTION
1	1	16732	Socket button head screw M5x20 A2-70
2	1	10550	Hex nut M5 A2-70
3	1	21554	Fuel line clamp Ø8-10 mm

Fuel system install

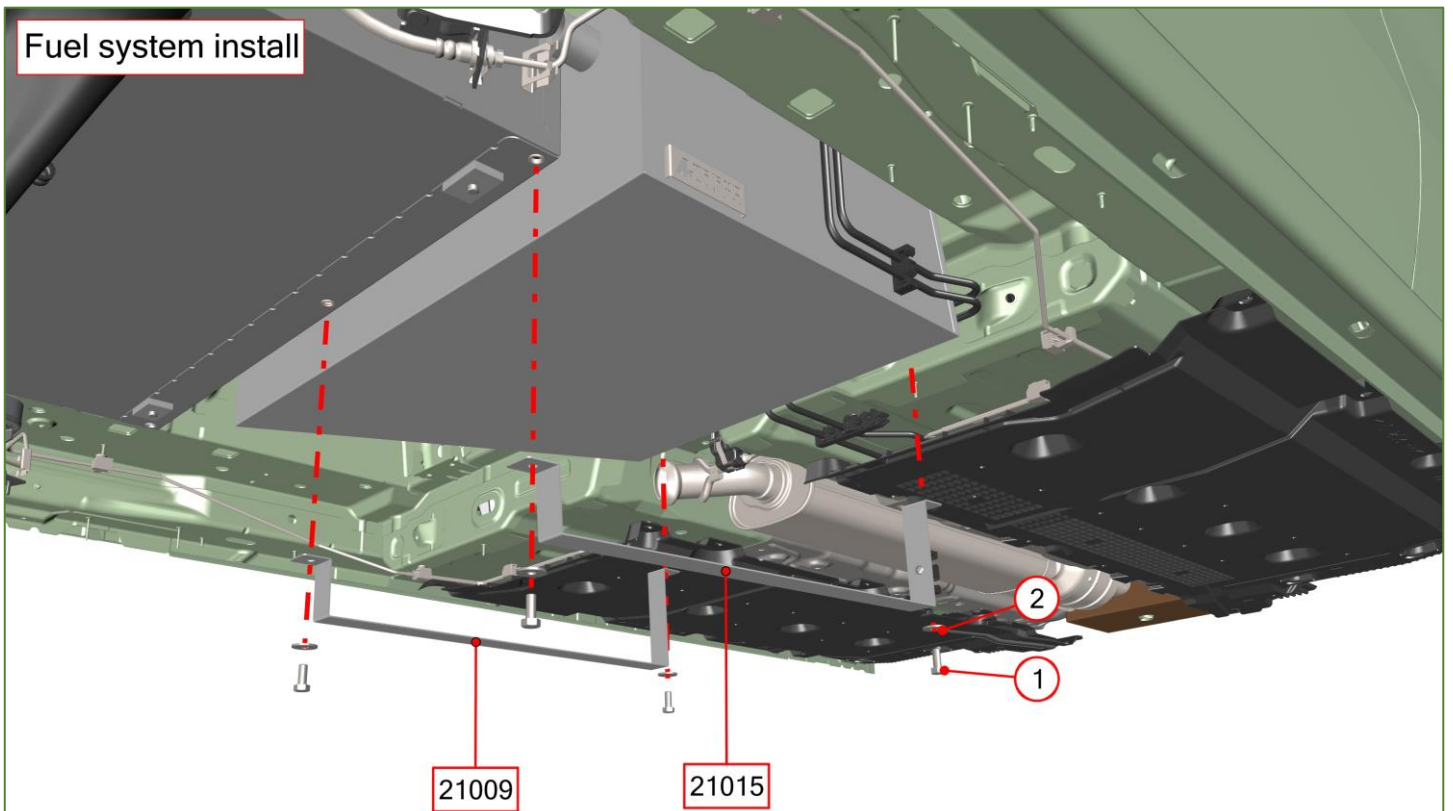

Bag #21527

Raise the fuel tank in position with a gearbox jack

NO.	QTY	PART	DESCRIPTION
1	4	145	Hex bolt M8x20 8.8
2	4	1246	Large washer M8 8.8

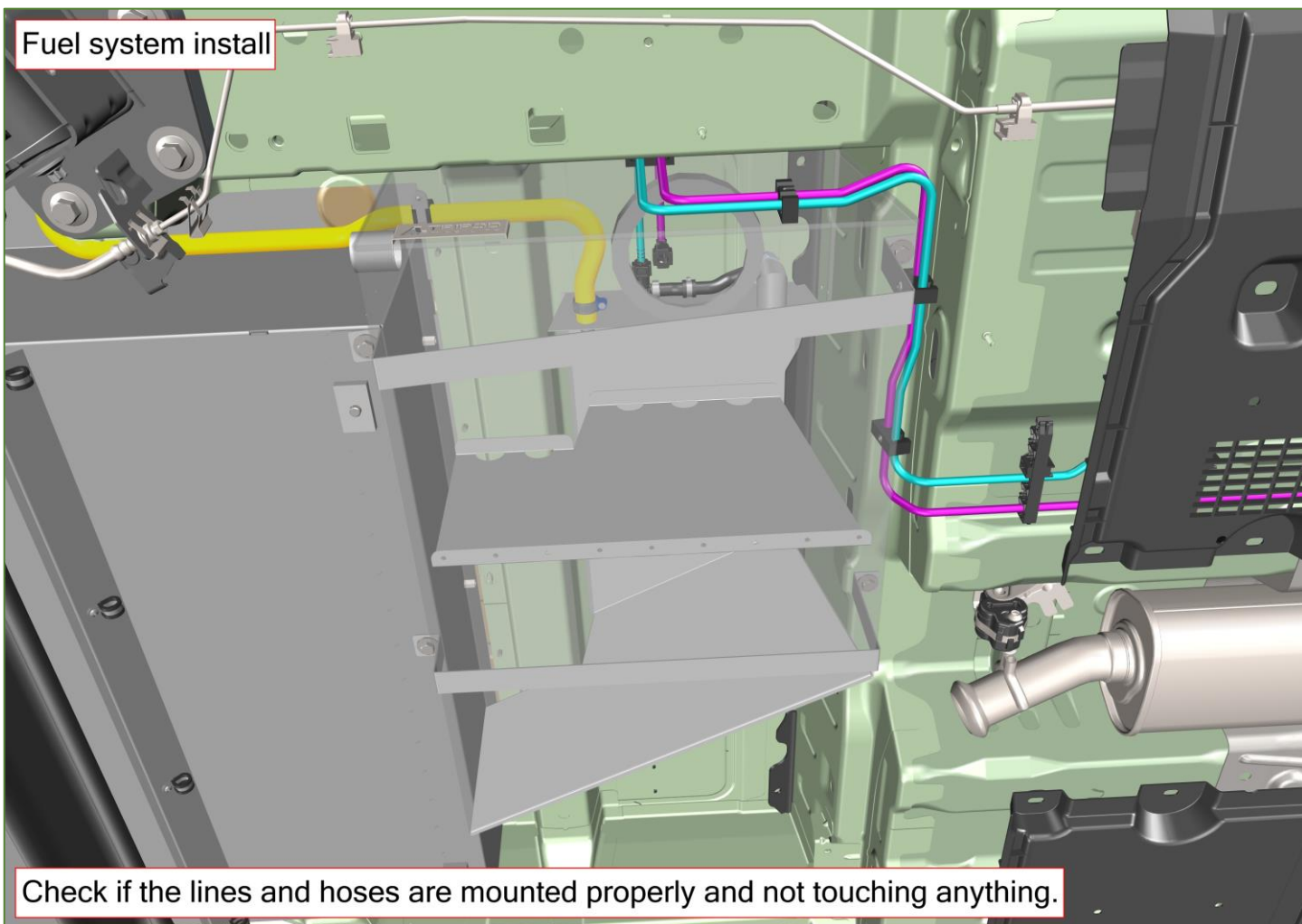
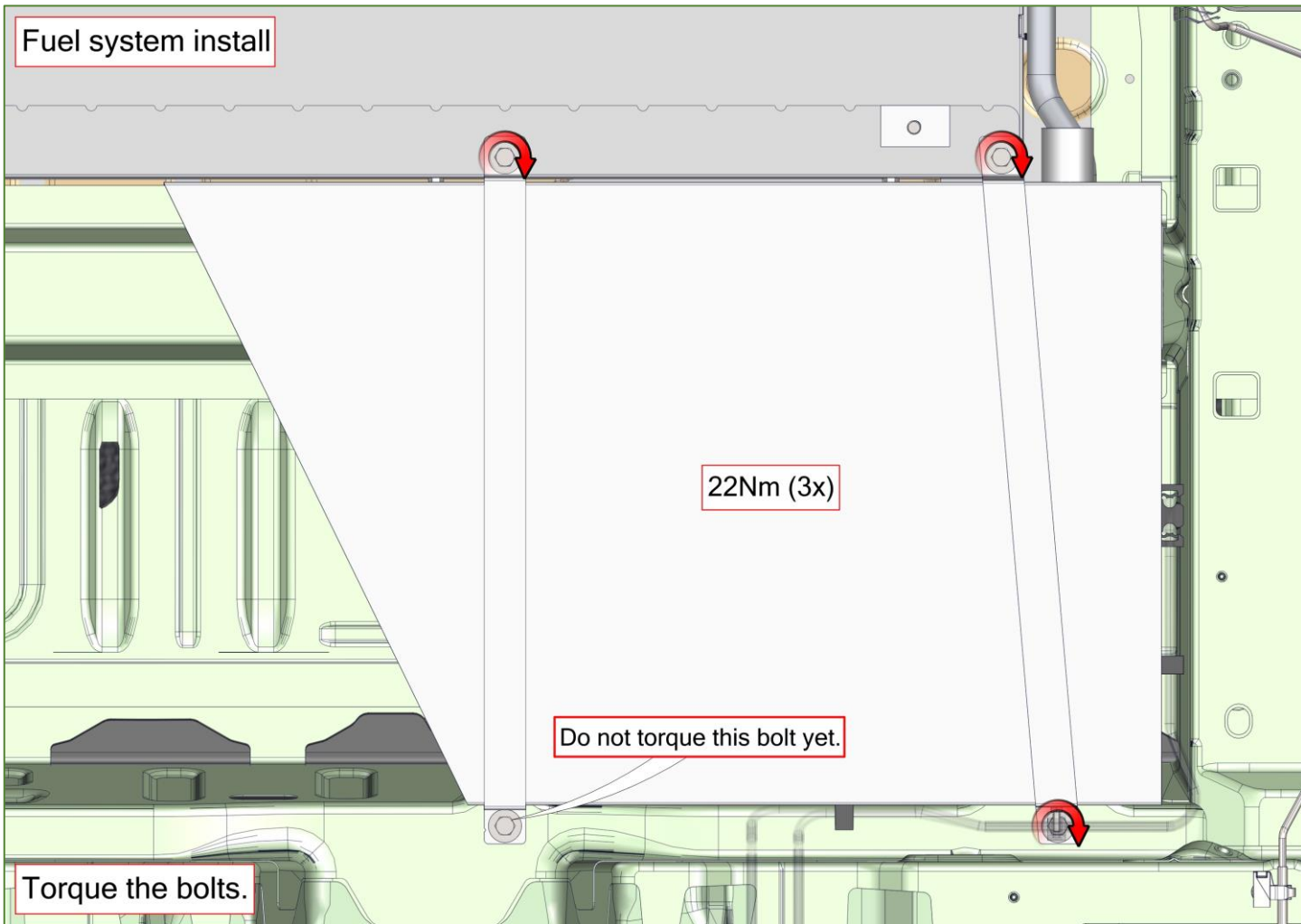



**Fuel system install**

Place the covers back and mount with OEM bolts. Before remounting these covers be sure the fuel and EVAP lines have been connected to the OEM system and are properly placed in the OEM clamps.

The new fuel/EVAP lines can be connected here.

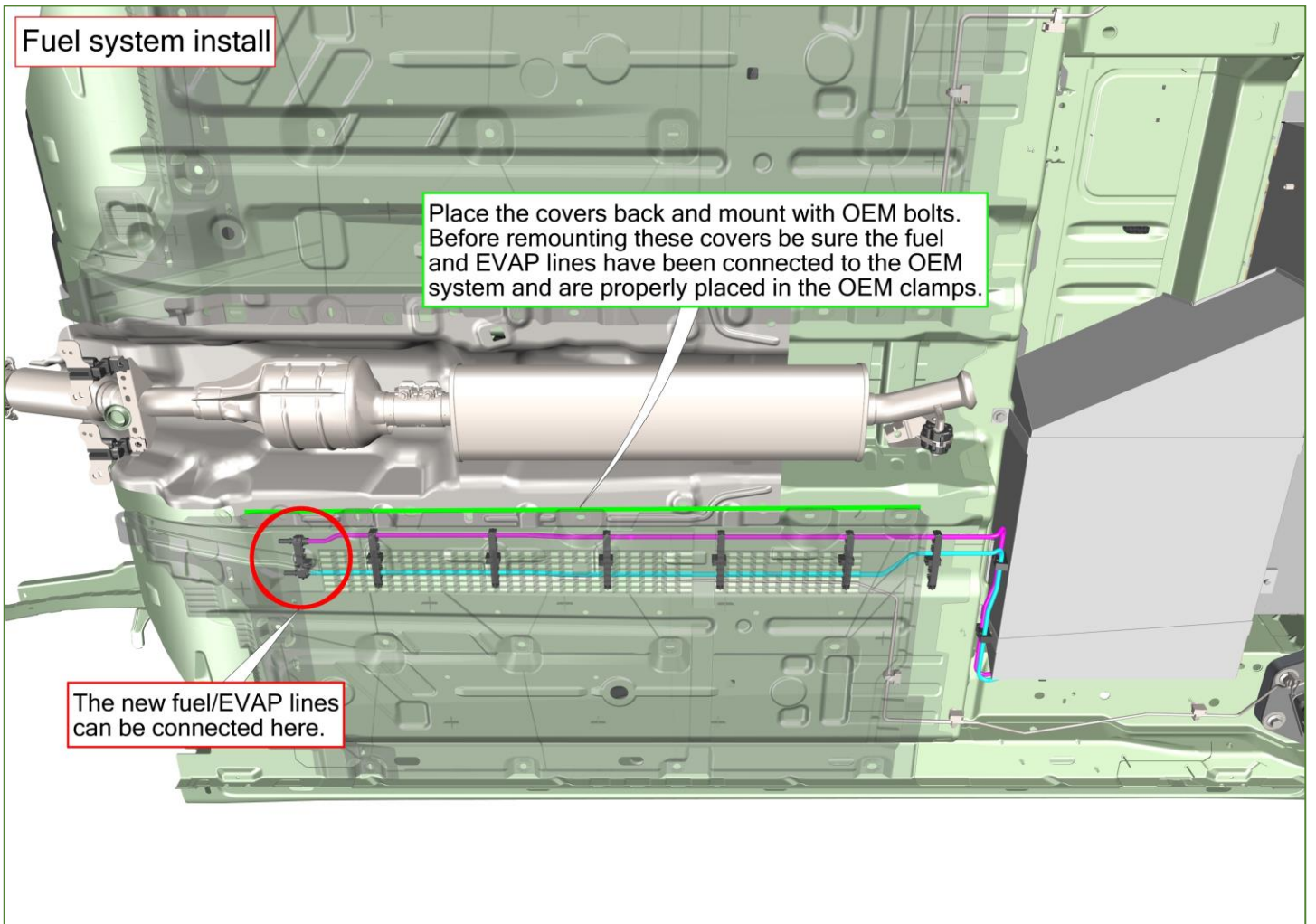

**Fuel system install**

Fix the breather hose to the side of the lowered floor. Torque 5Nm.

Bag #21527

NO.	QTY	PART	DESCRIPTION
1	2	3590	Hose clamp RSGU 25/15
2	2	10205	Torque nut M5 A2-70

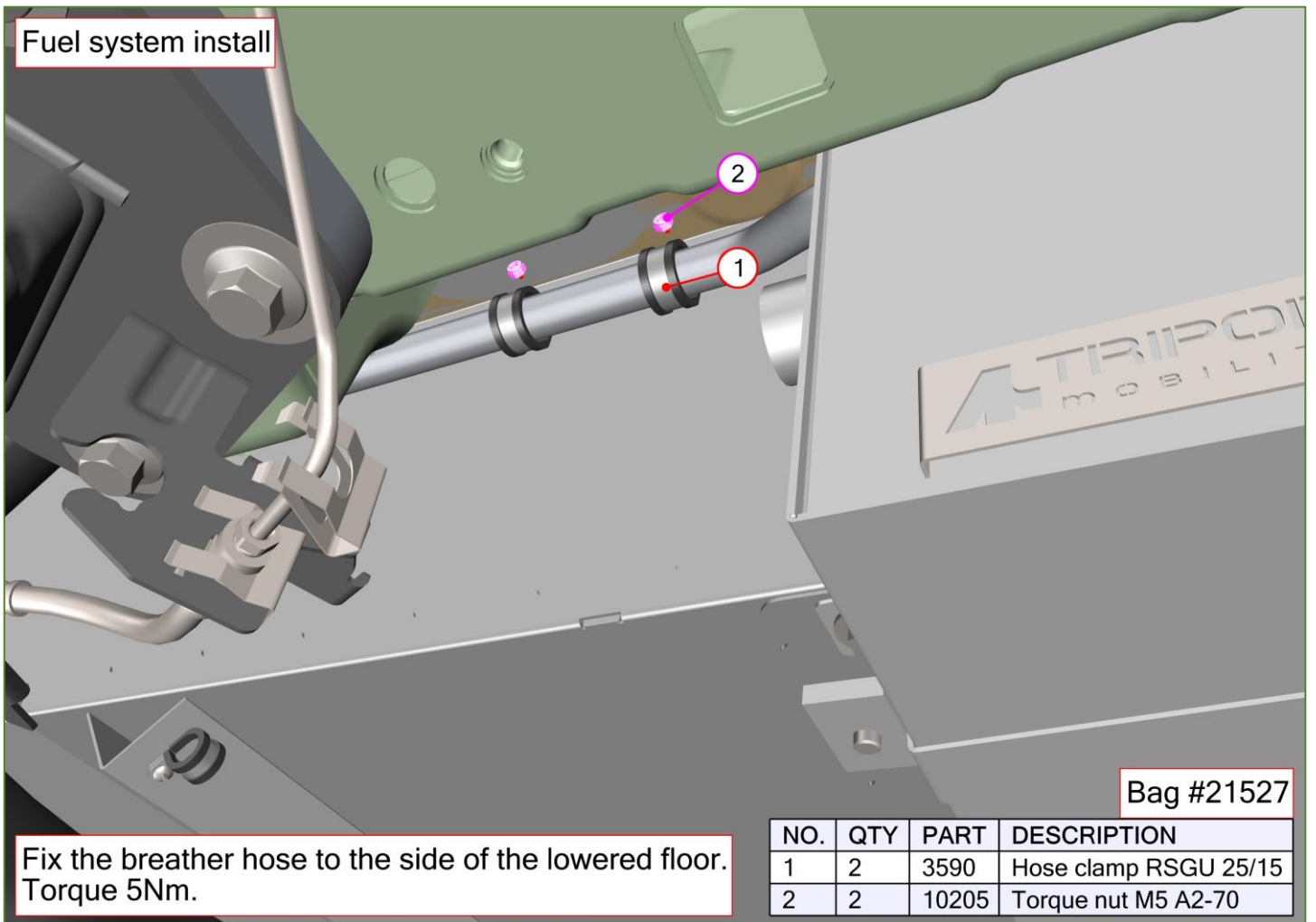

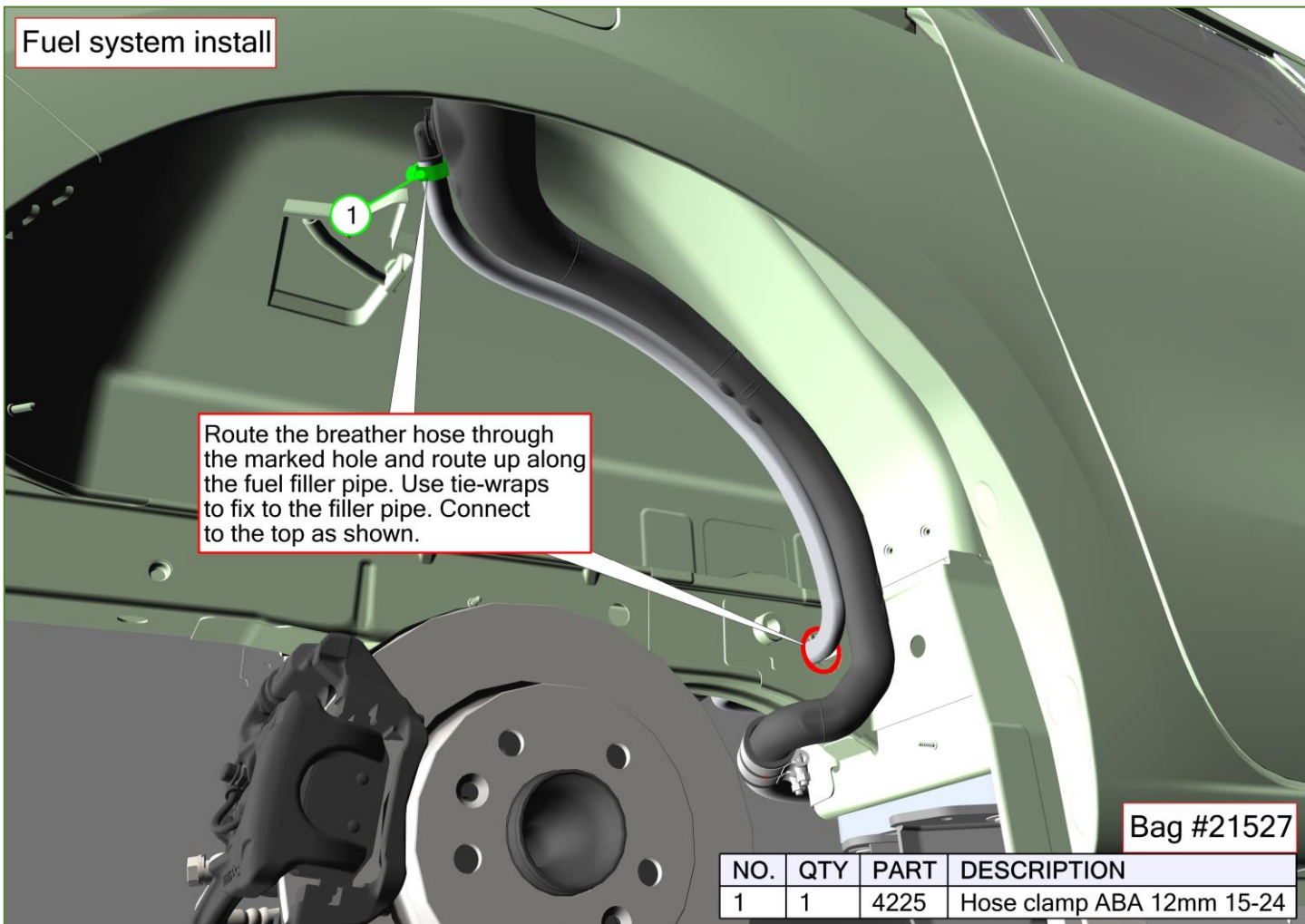
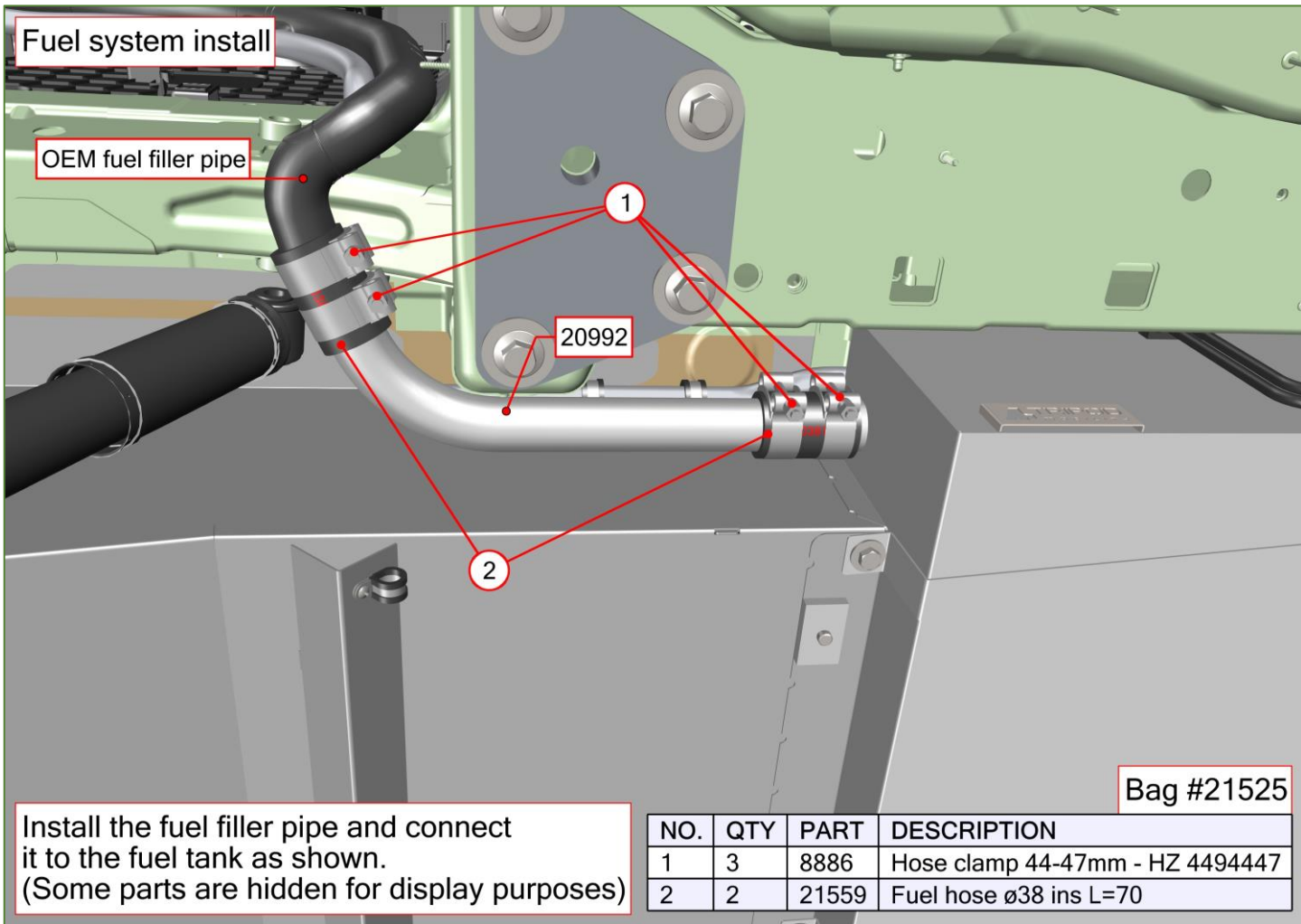

Exhaust install

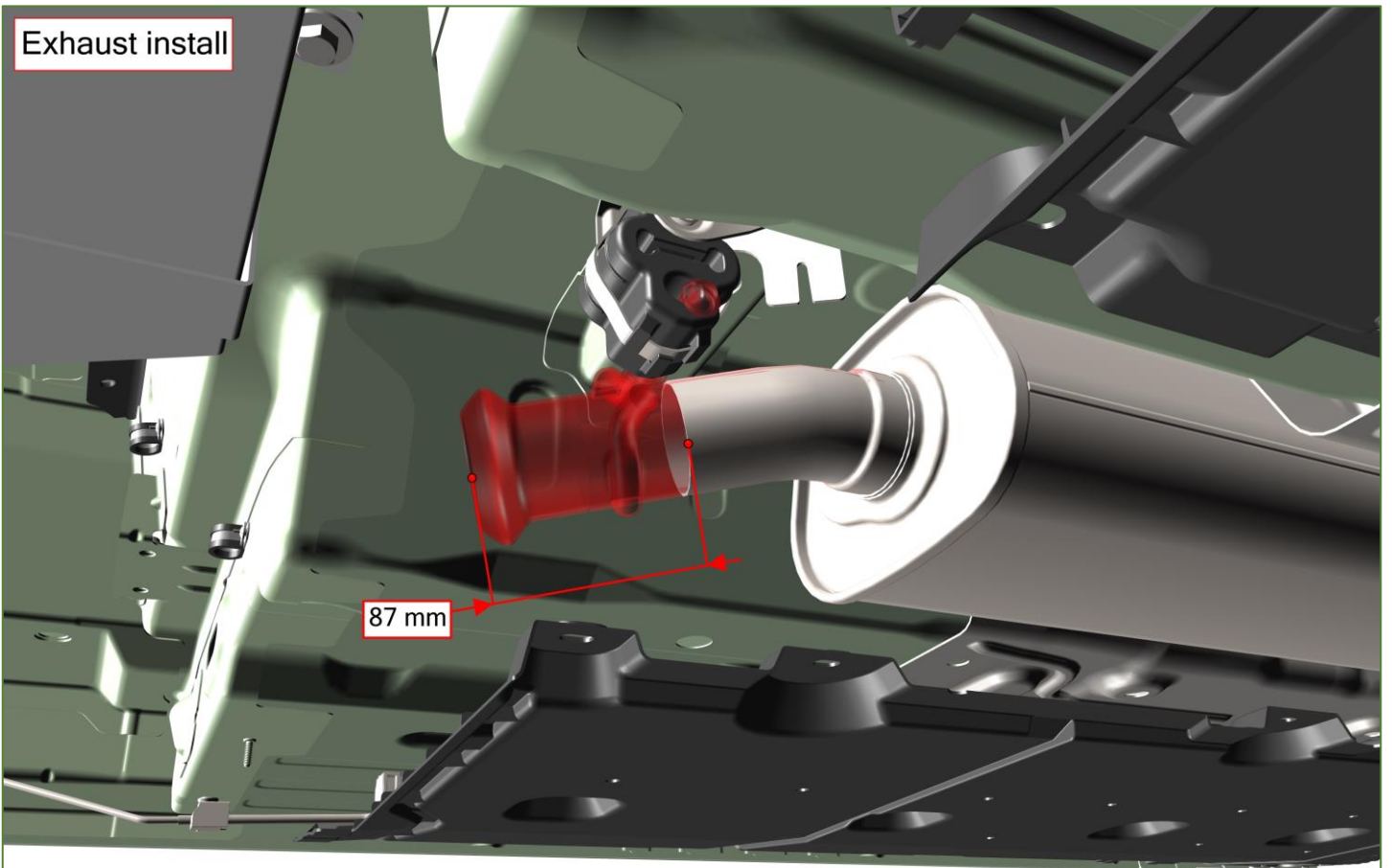

Cut off the end pipe of the rear muffler as shown.

Exhaust install



Fold the exhaust heatshield as shown.



Exhaust install

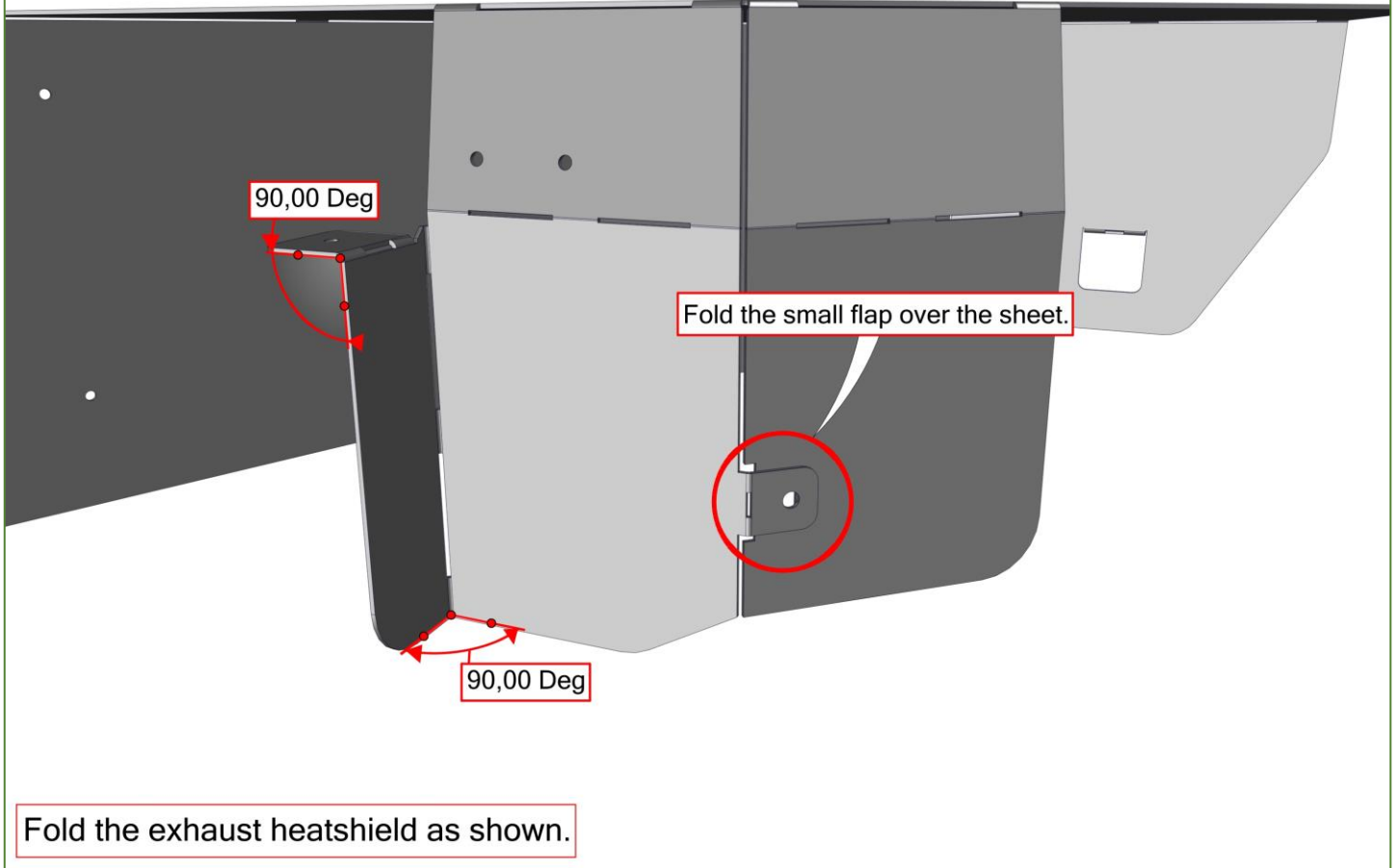

Exhaust install

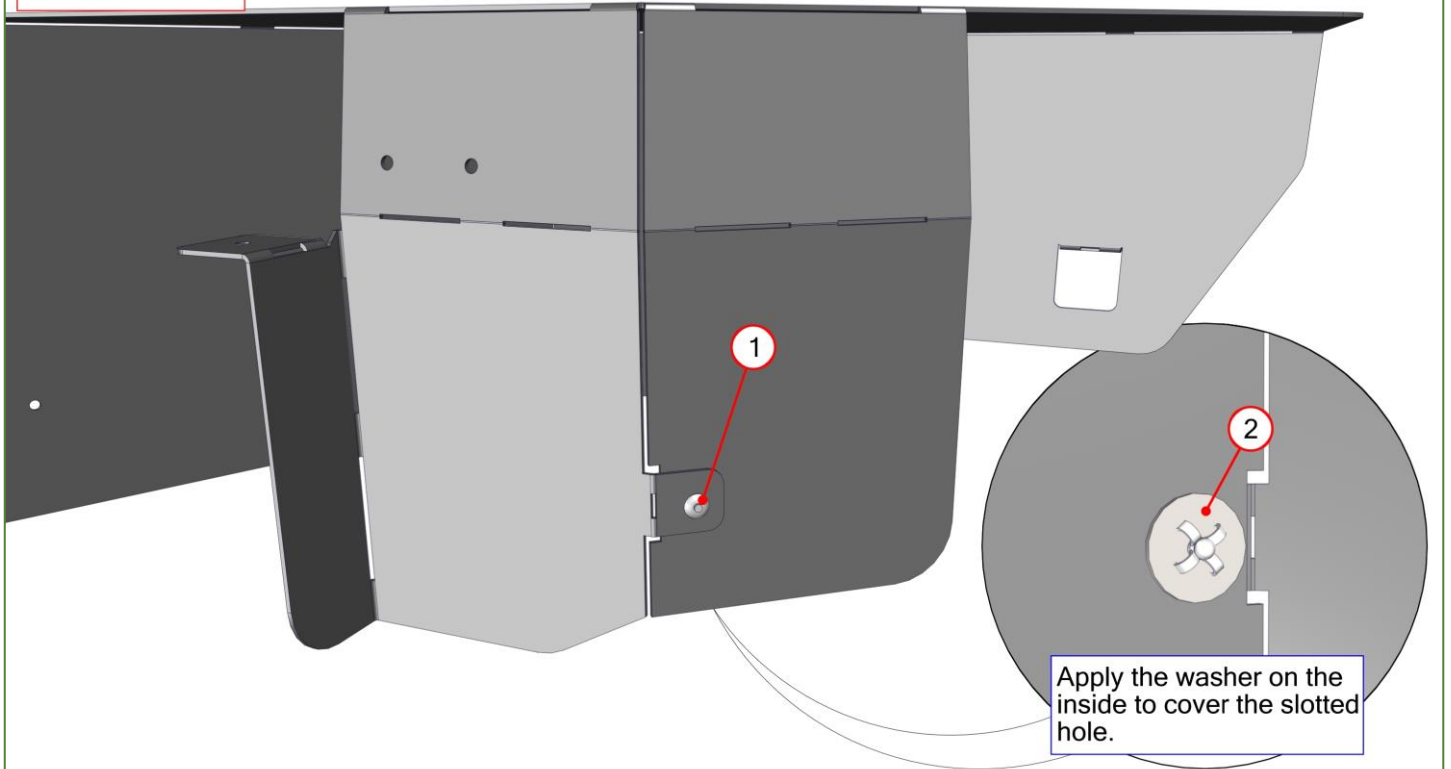

Mount with a pop rivet.

Bag #21007

NO.	QTY	PART	DESCRIPTION
1	1	7991	Pop rivet 4,0x12 alu/st
2	1	4	Large washer M4 4x20x1,25

Exhaust install

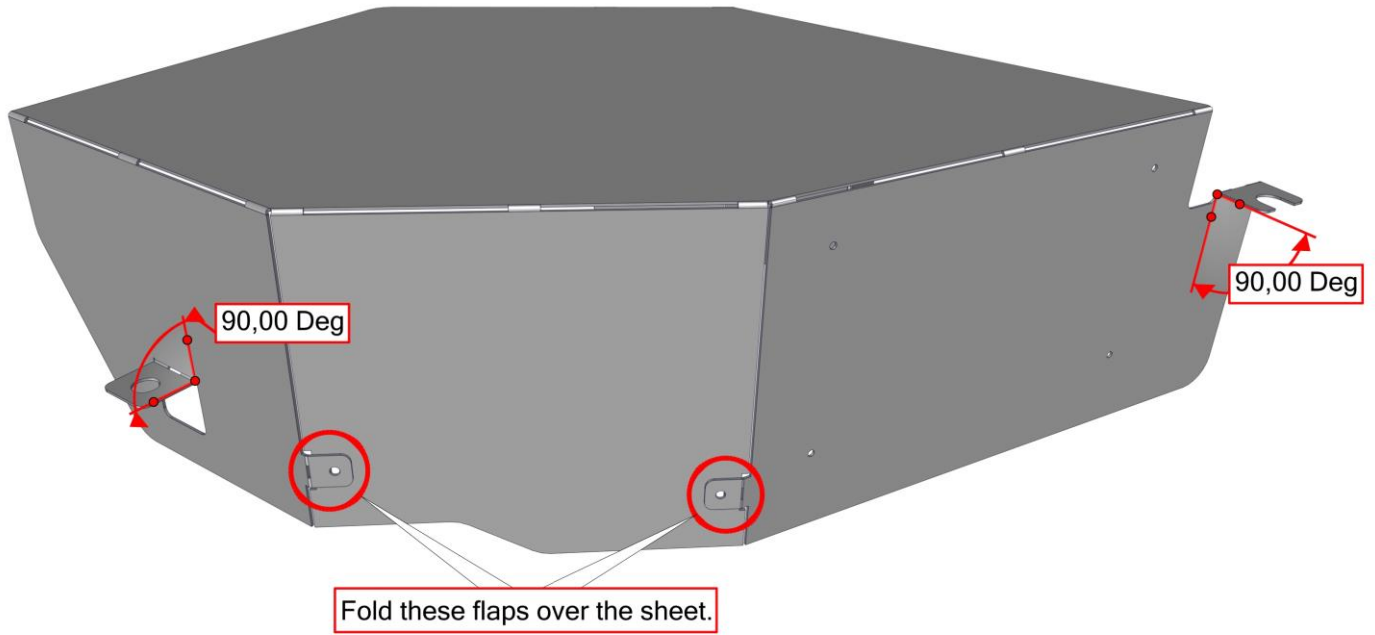

Fold the exhaust heatshield as shown.

Exhaust install

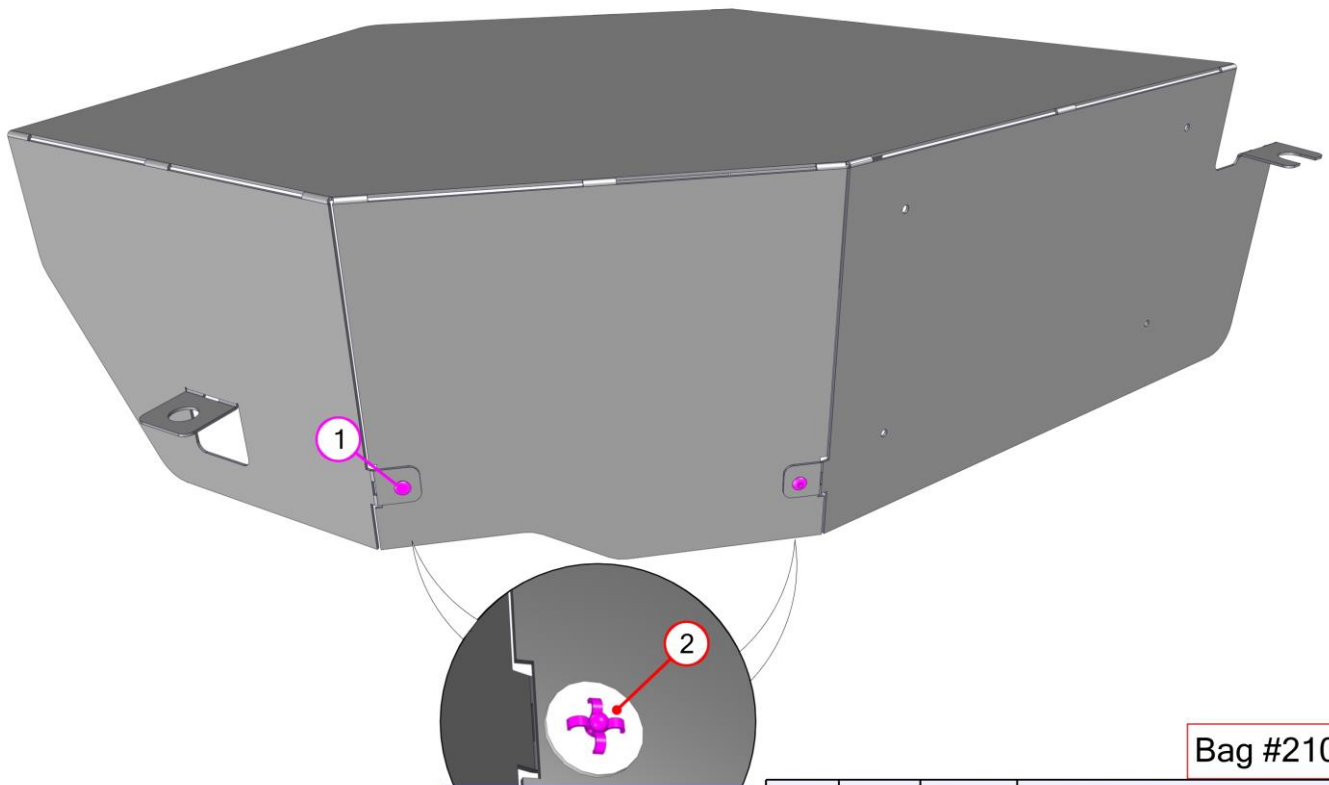

Apply the washer on the inside to cover the slotted hole.

NO.	QTY	PART	DESCRIPTION
1	2	7991	Pop rivet 4,0x12 alu/st
2	2	4	Large washer M4 4x20x1,25

Exhaust install

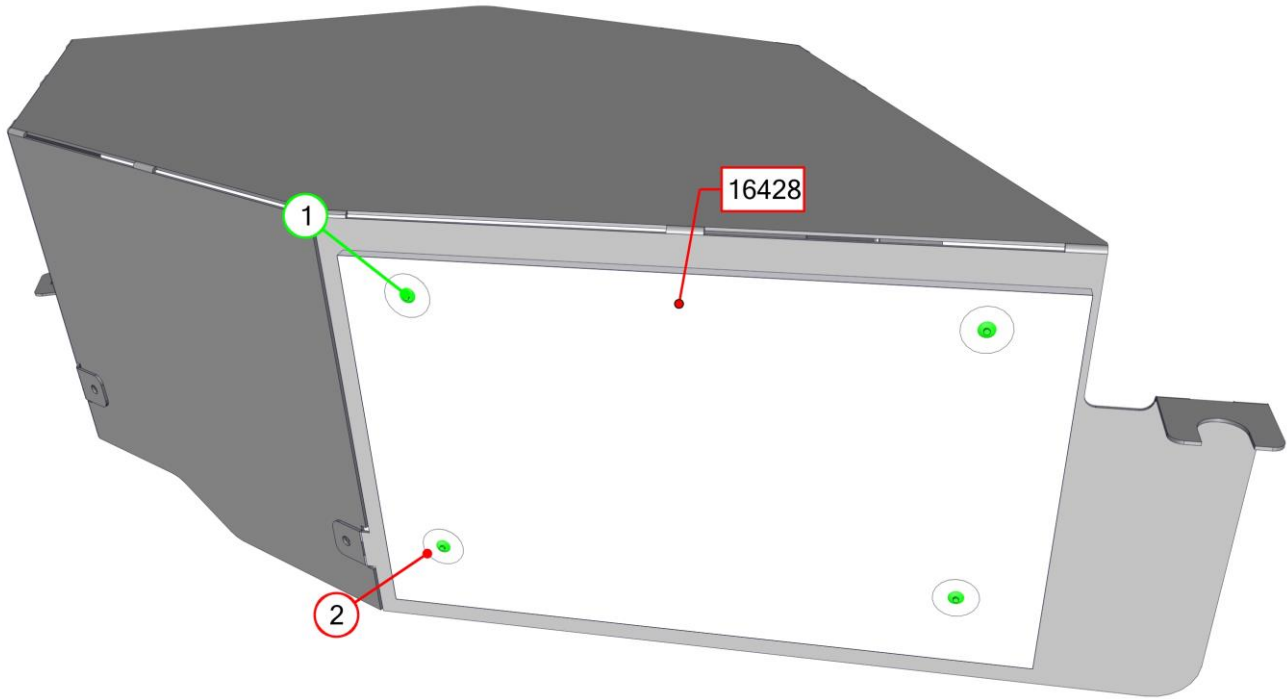

Bag #21007

Mount the stick-on heatshield to the outside of the metal heatshield. Apply the pop rivets to the holes in the surface of the metal heatshield.

NO.	QTY	PART	DESCRIPTION
1	4	7991	Pop rivet 4,0x12 alu/st
2	4	4	Large washer M4 4x20x1,25

Exhaust install

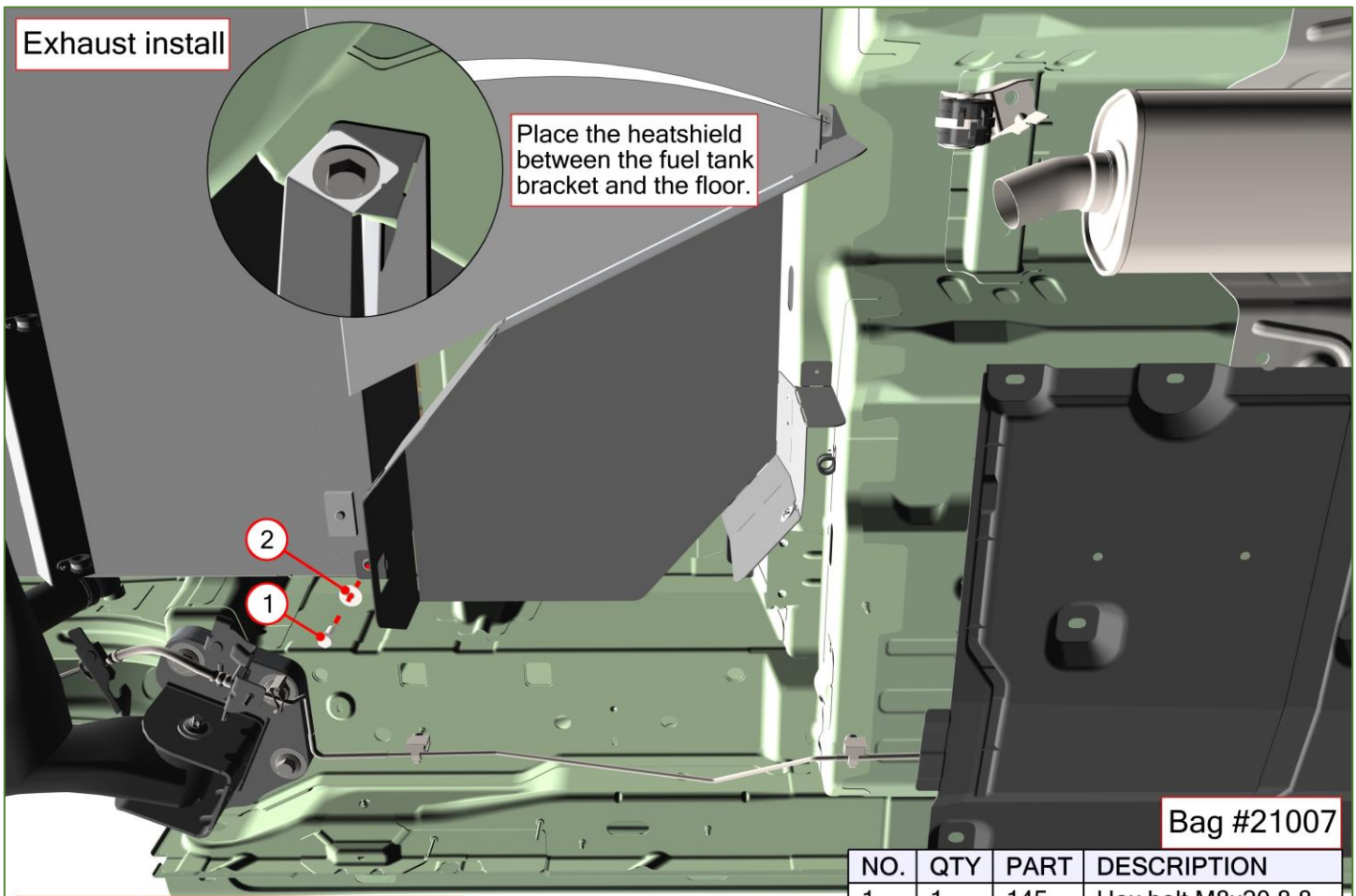

Place the heatshield between the fuel tank bracket and the floor.

Bag #21007

Install the heatshield as shown.

NO.	QTY	PART	DESCRIPTION
1	1	145	Hex bolt M8x20 8.8
2	1	1246	Large washer M8 8.8



Exhaust install

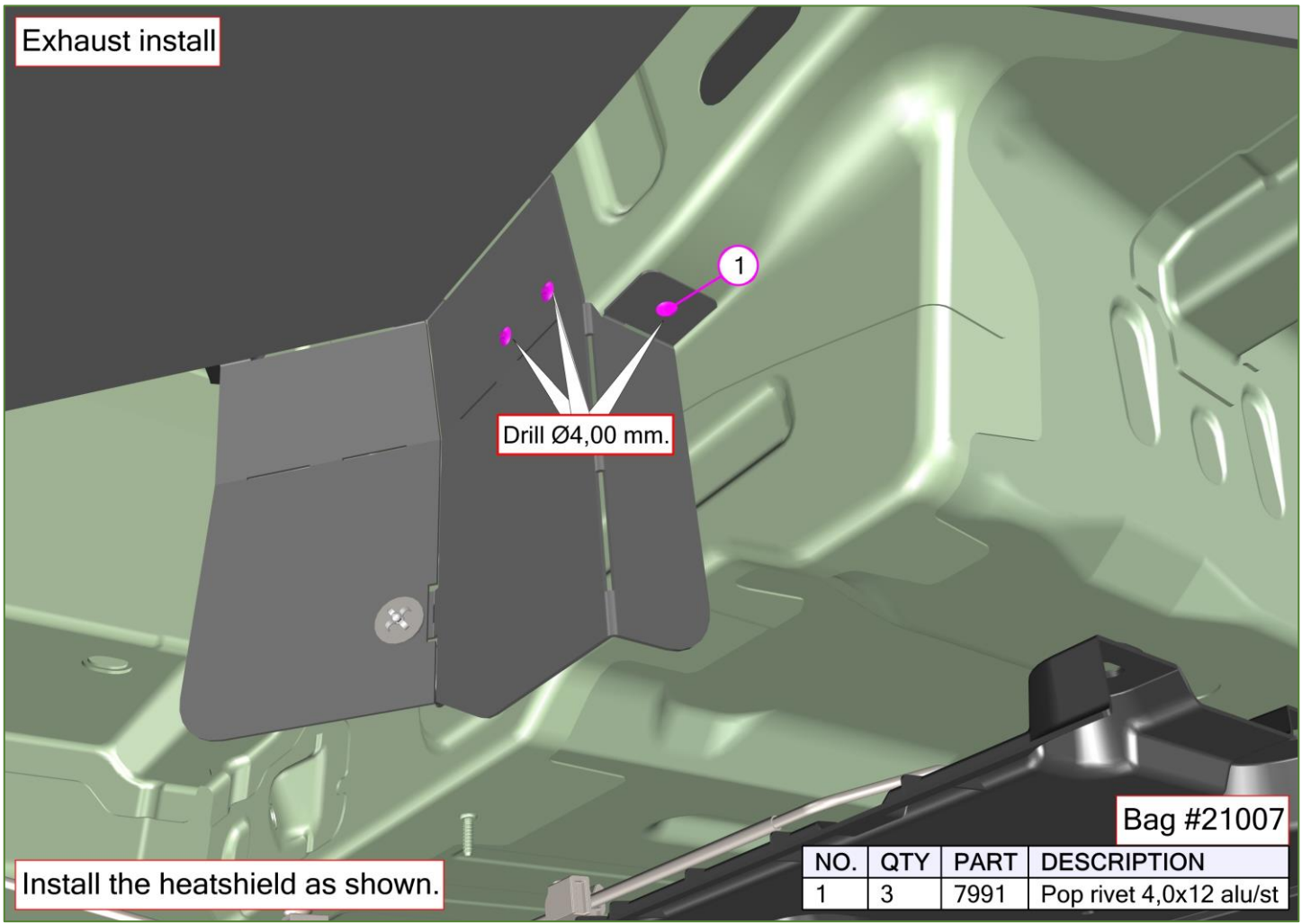

Drill Ø4,00 mm.

1

Bag #21007

Install the heatshield as shown.

NO.	QTY	PART	DESCRIPTION
1	3	7991	Pop rivet 4,0x12 alu/st

Exhaust install

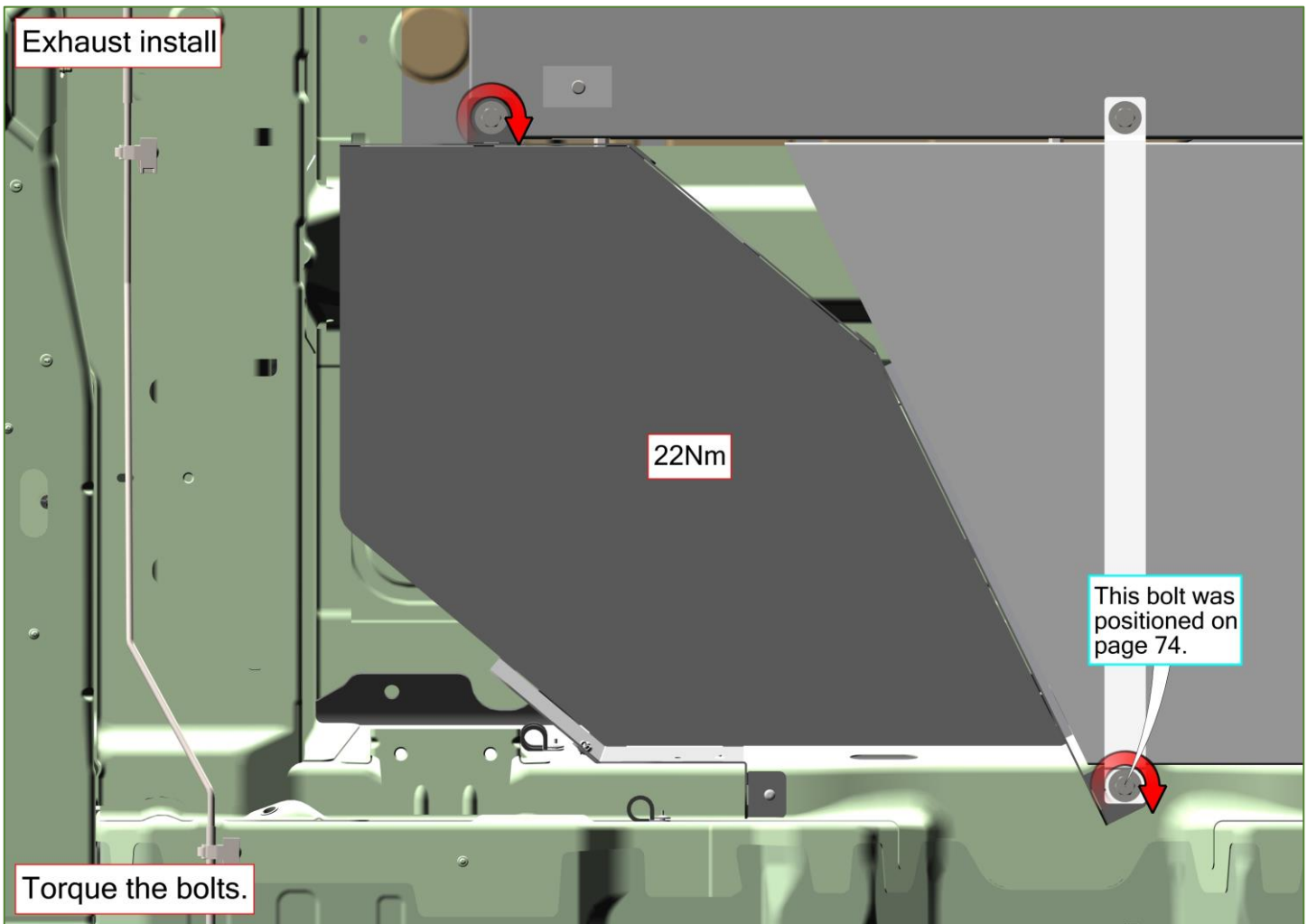

22Nm

This bolt was positioned on page 74.

Torque the bolts.

Exhaust install

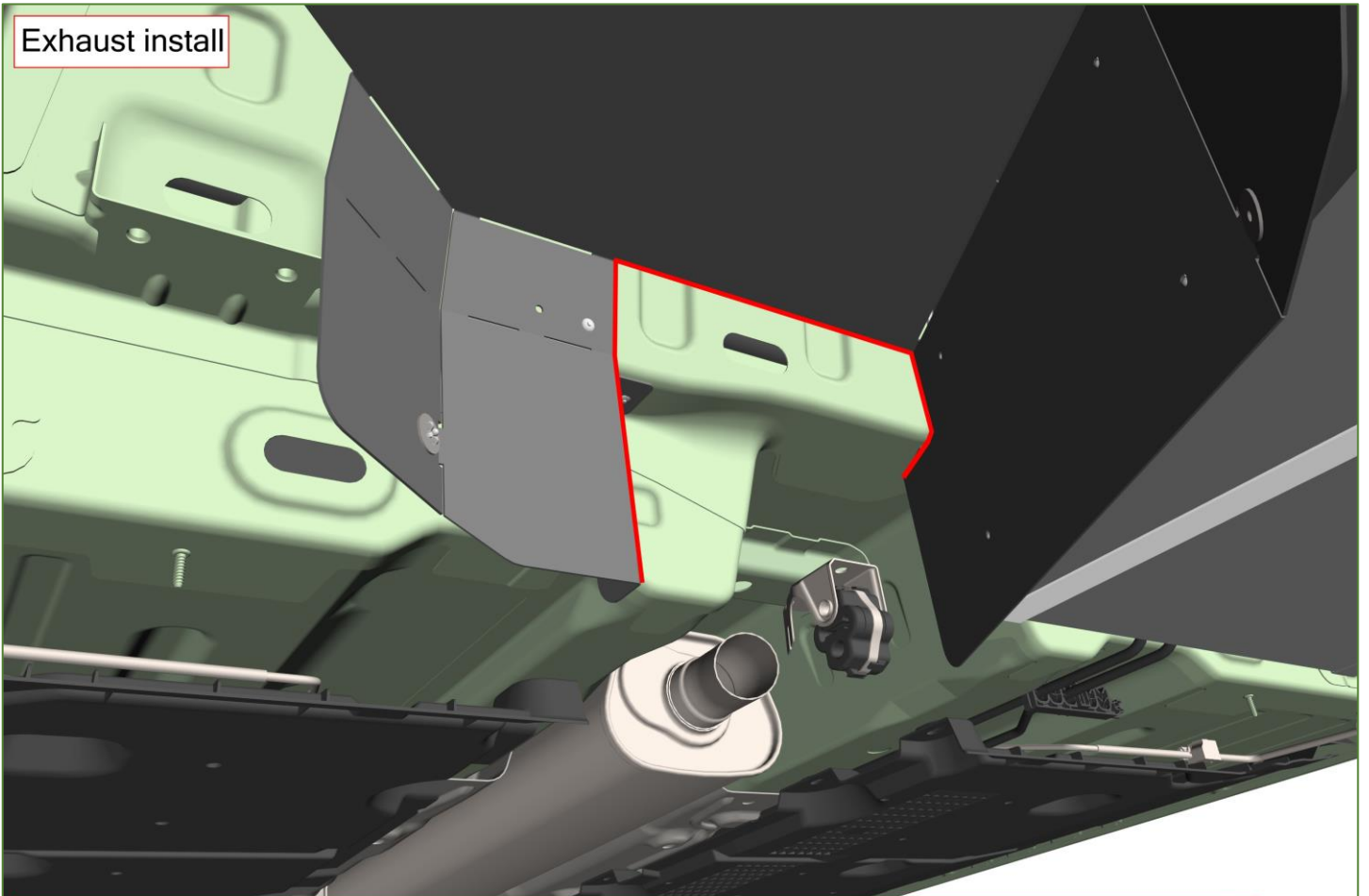

Position the remainder of the OEM heatshield through the opening in the new heatshield.

Exhaust install

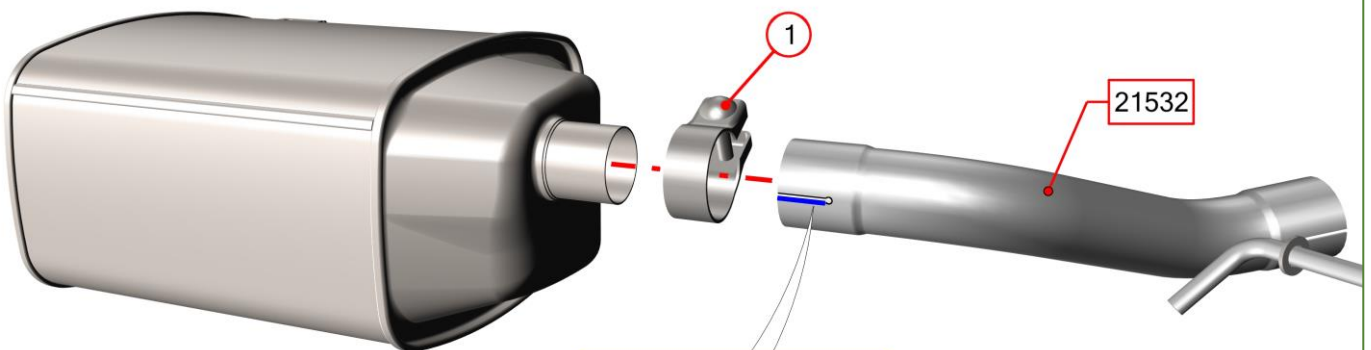

Be sure the outside slit is positioned at the side.

Bag #21007

Mount the new exhaust pipe to the rear muffler as shown.

NO.	QTY	PART	DESCRIPTION
1	1	5258	Exhaust clamp Ø54,5

## Exhaust install

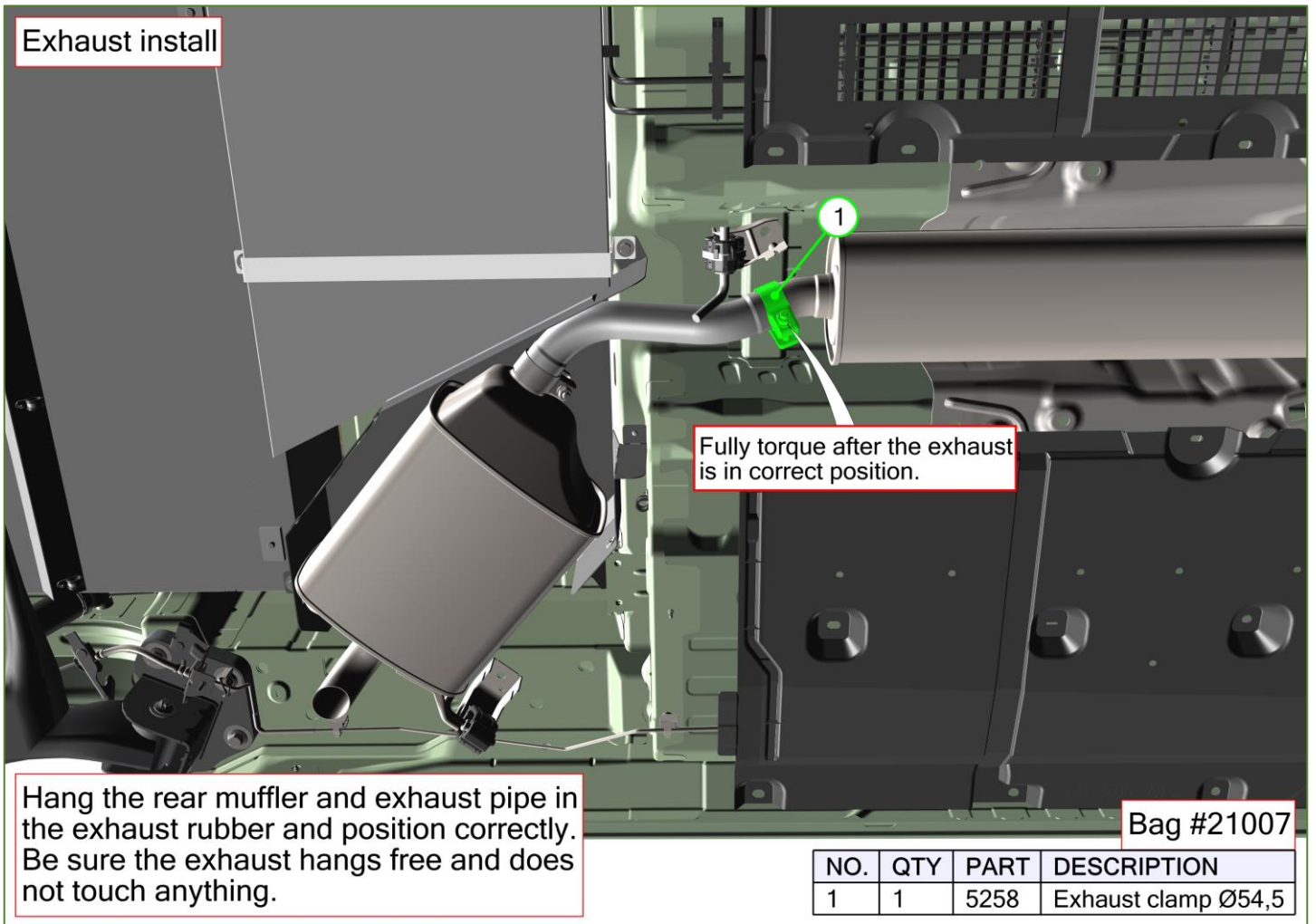

## Exhaust install

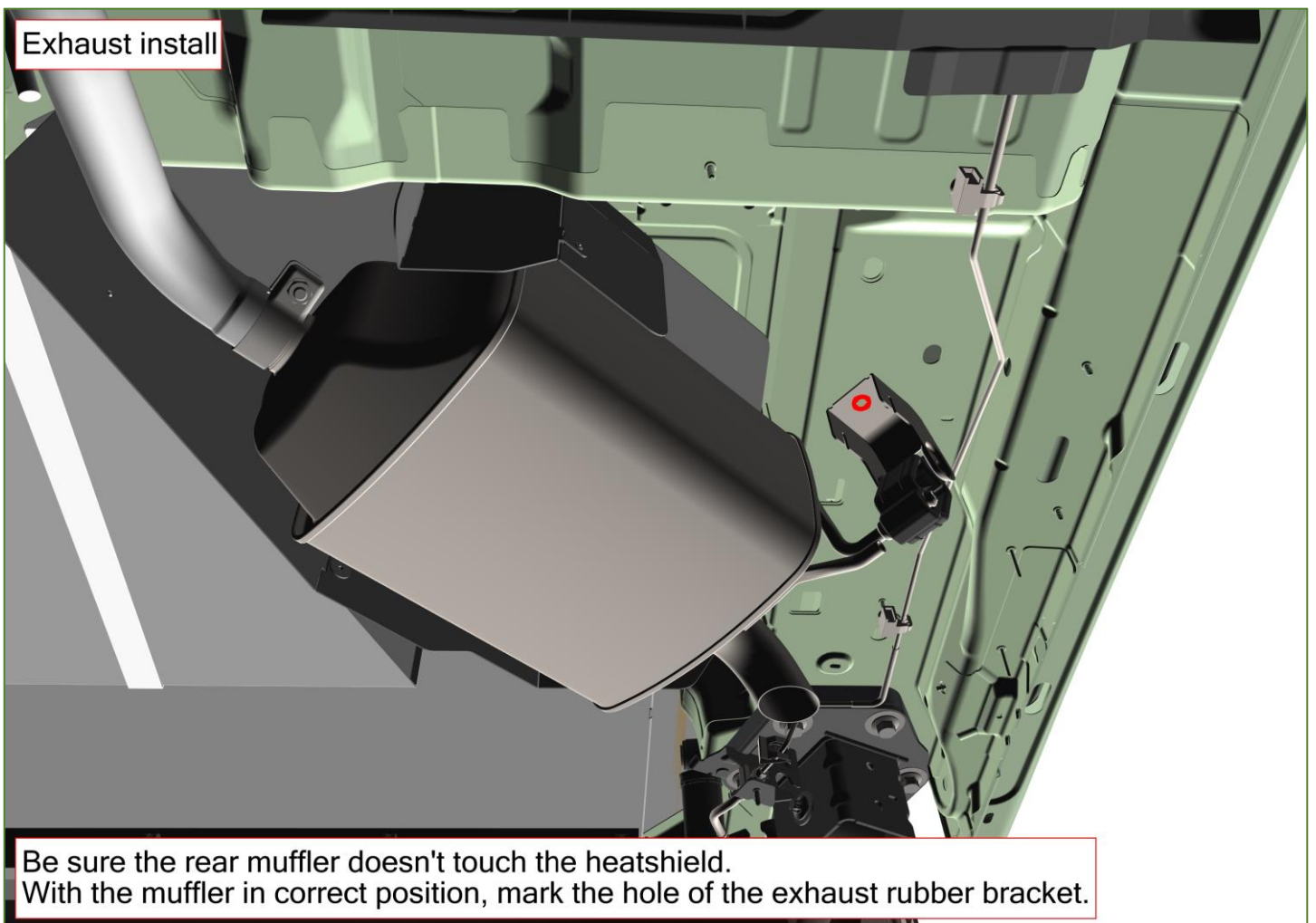



Exhaust install

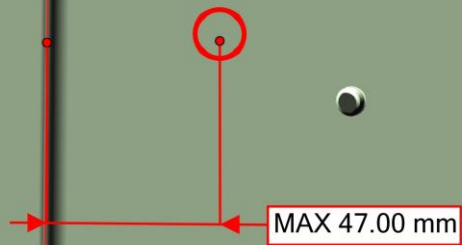

Lower the exhaust and drill Ø13.5 mm.

Exhaust install



Bag #21007

NO.	QTY	PART	DESCRIPTION
1	1	10396	Flat head riveted nut M10x24 8.8

Exhaust install

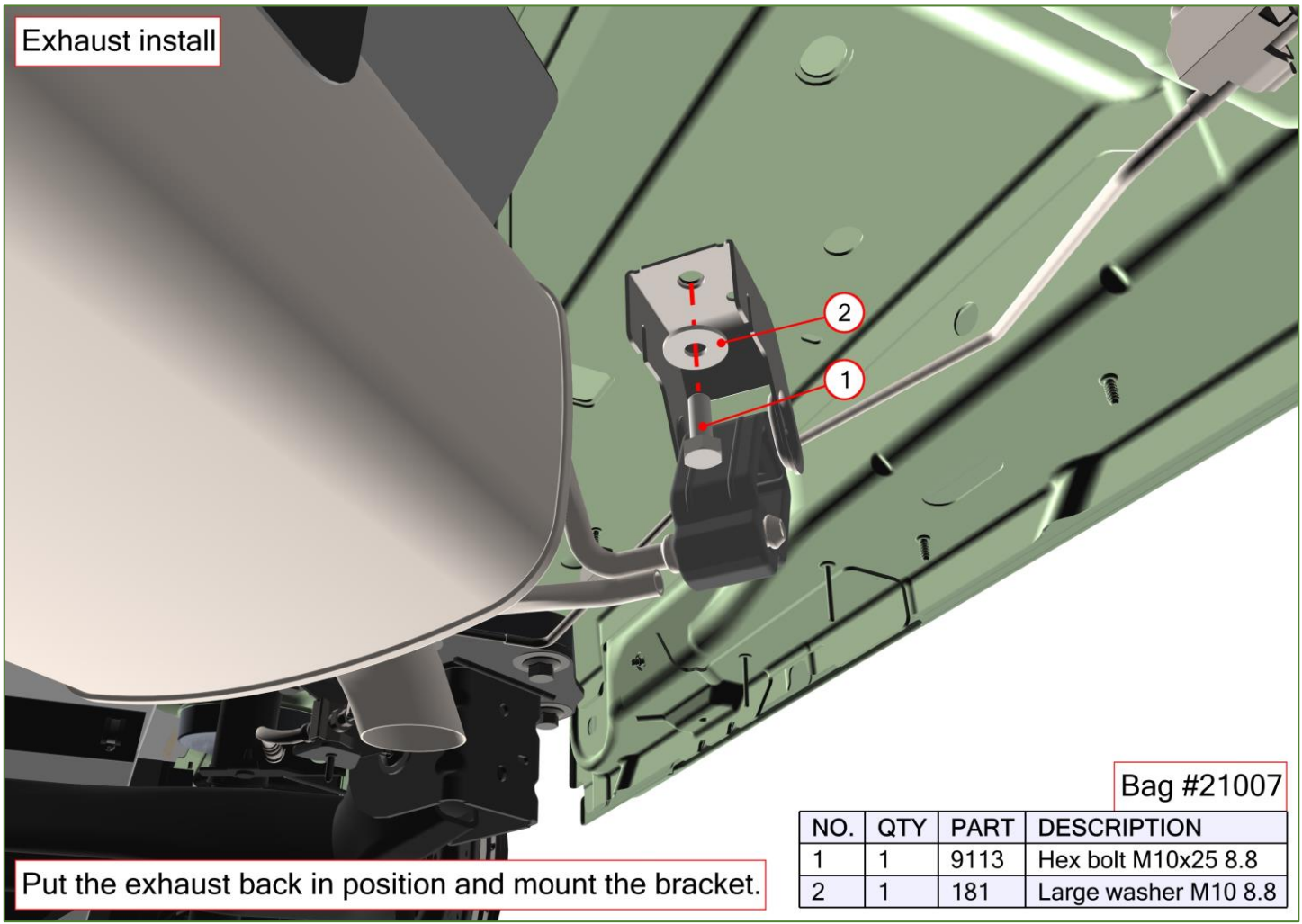

Bag #21007

NO.	QTY	PART	DESCRIPTION
1	1	9113	Hex bolt M10x25 8.8
2	1	181	Large washer M10 8.8

Exhaust install

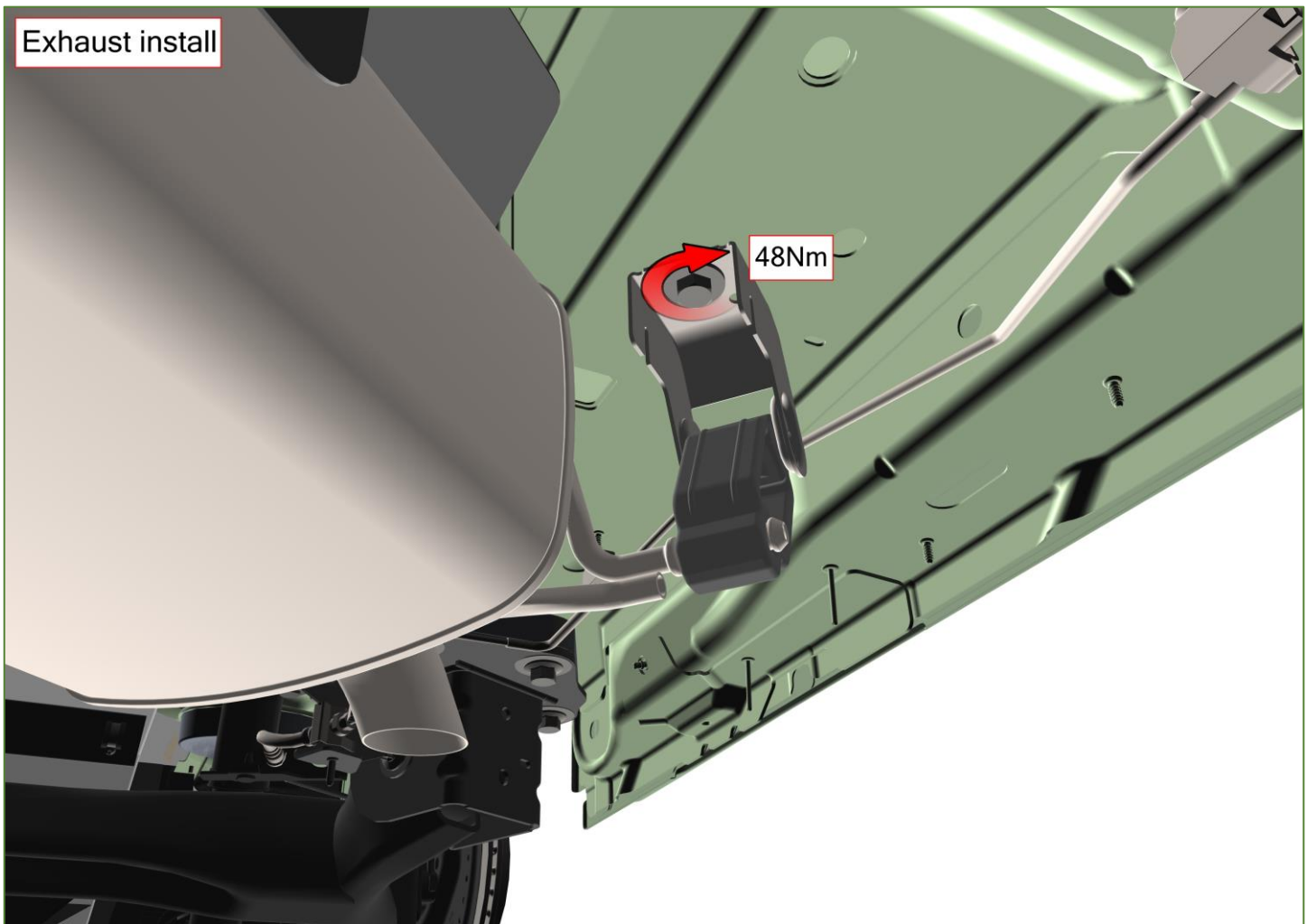

Exhaust install

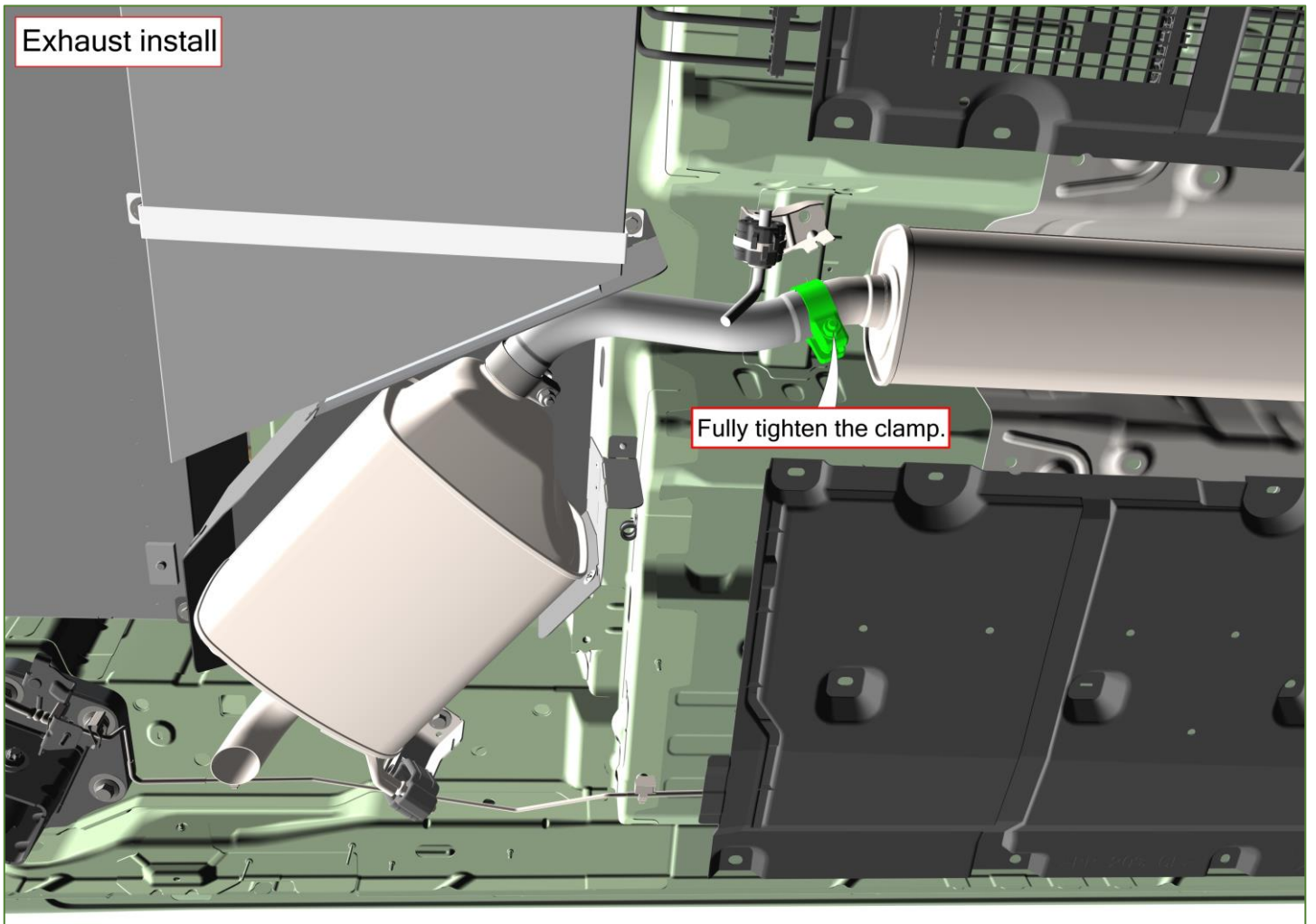

Fully tighten the clamp.

Exhaust install

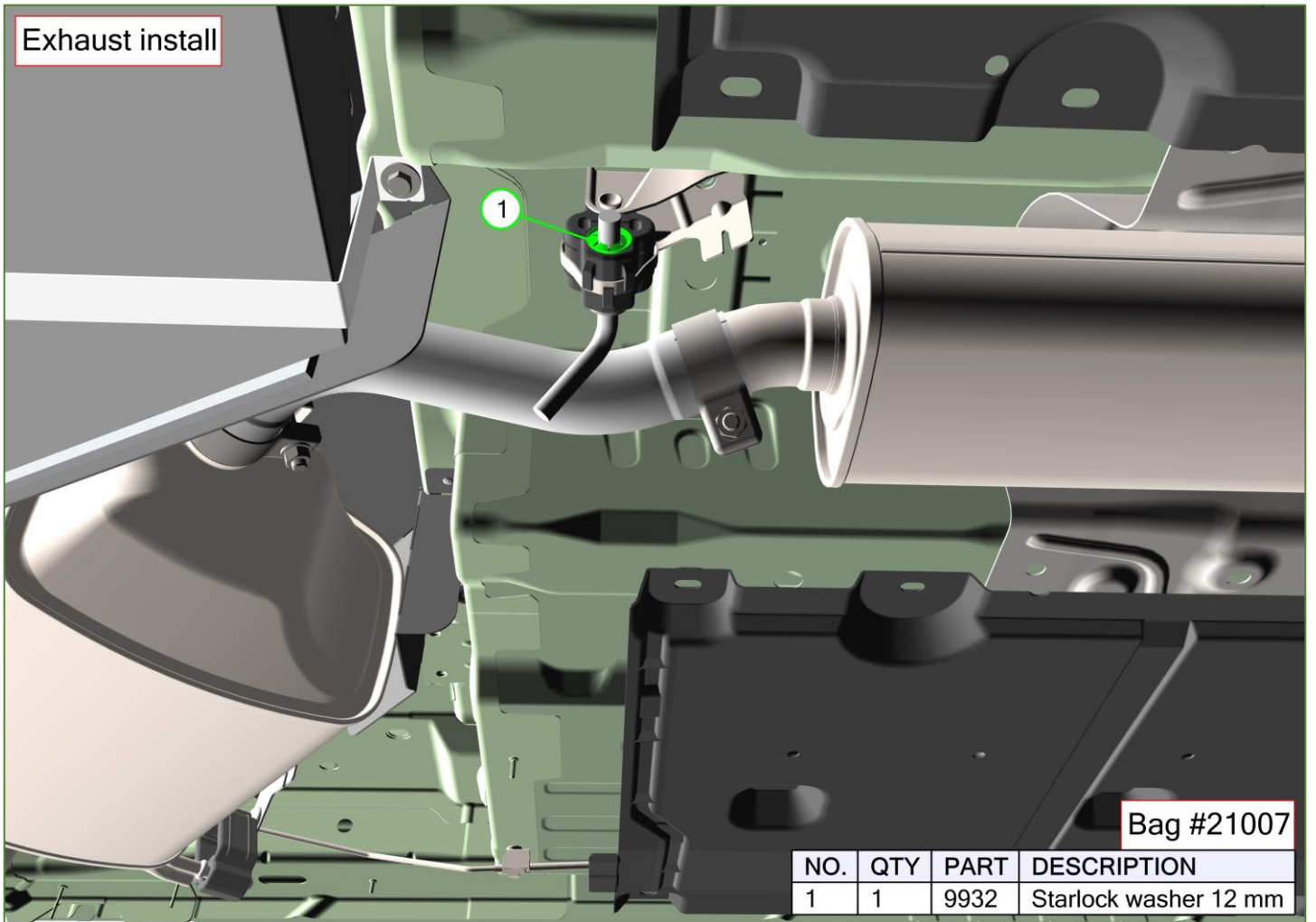

Bag #21007

NO.	QTY	PART	DESCRIPTION
1	1	9932	Starlock washer 12 mm



## Cavity protection coating

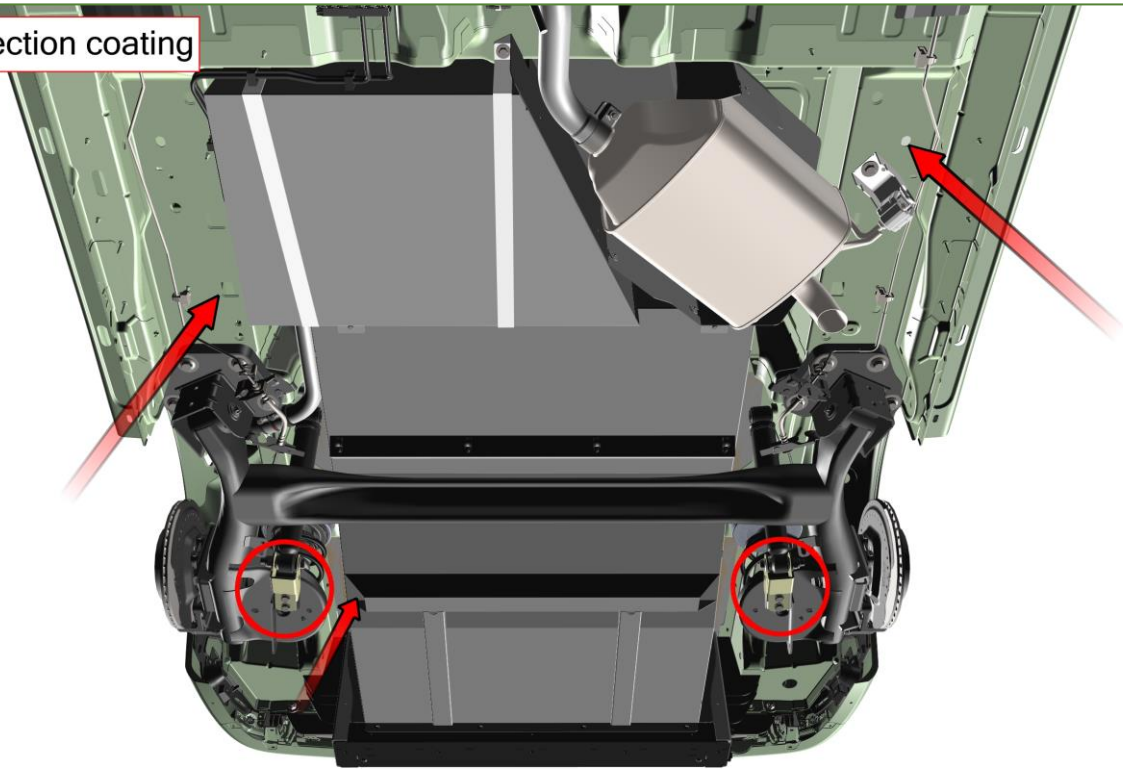

The arrows/circles are only a few of the spots that need the treatment. Take this as an example and coat all similar spots.

Apply cavity protection coating in all hollow/open areas on the bottom of the conversion to prevent rust in the future. This includes all hollow parts that are affected by the conversion, whether it's a Tripod part or an OEM part which has been cut open.

## Bottom finished

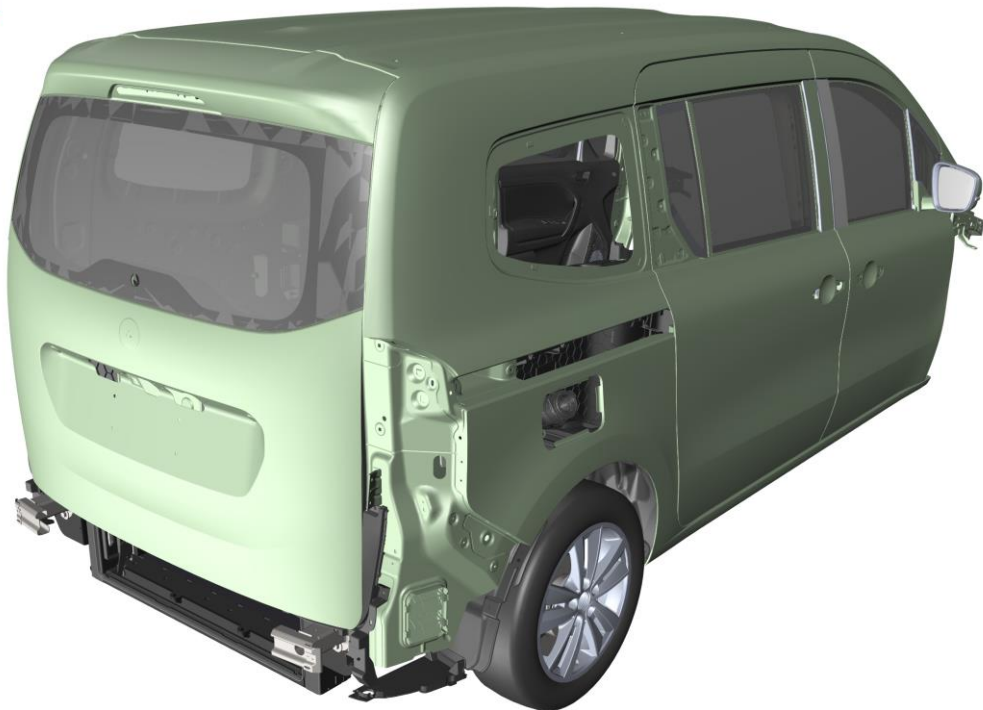

Put the right side wheelarch and both wheels back on the vehicle.

## Upholstery

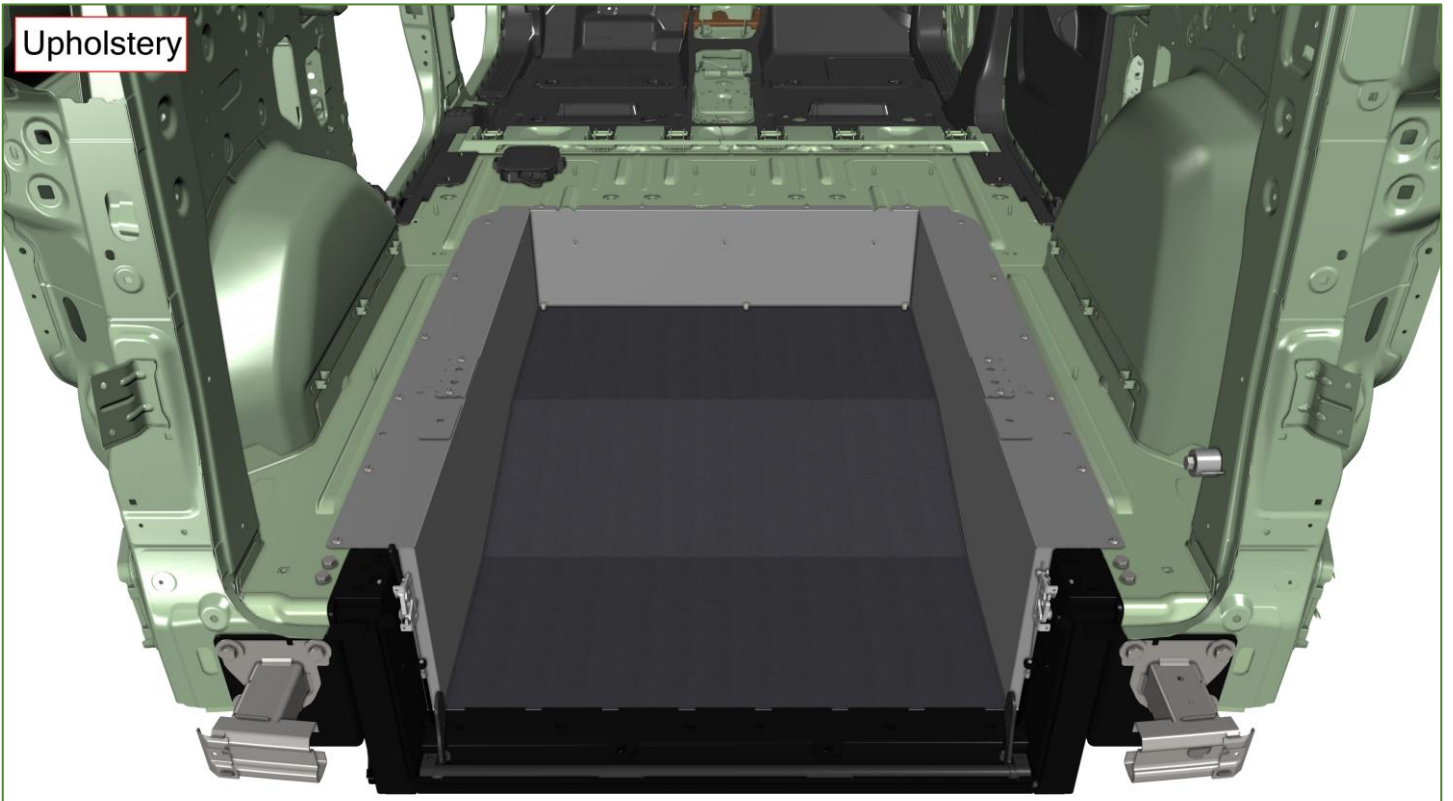

Before placing the floor cover, use an airgun to blow all metal bits off the floor. Degrease afterwards. When the floor is perfectly clean, place the floor cover in correct position. Fix the rear half temporarily in place. For example, by placing something heavy on the rear half.

## Upholstery

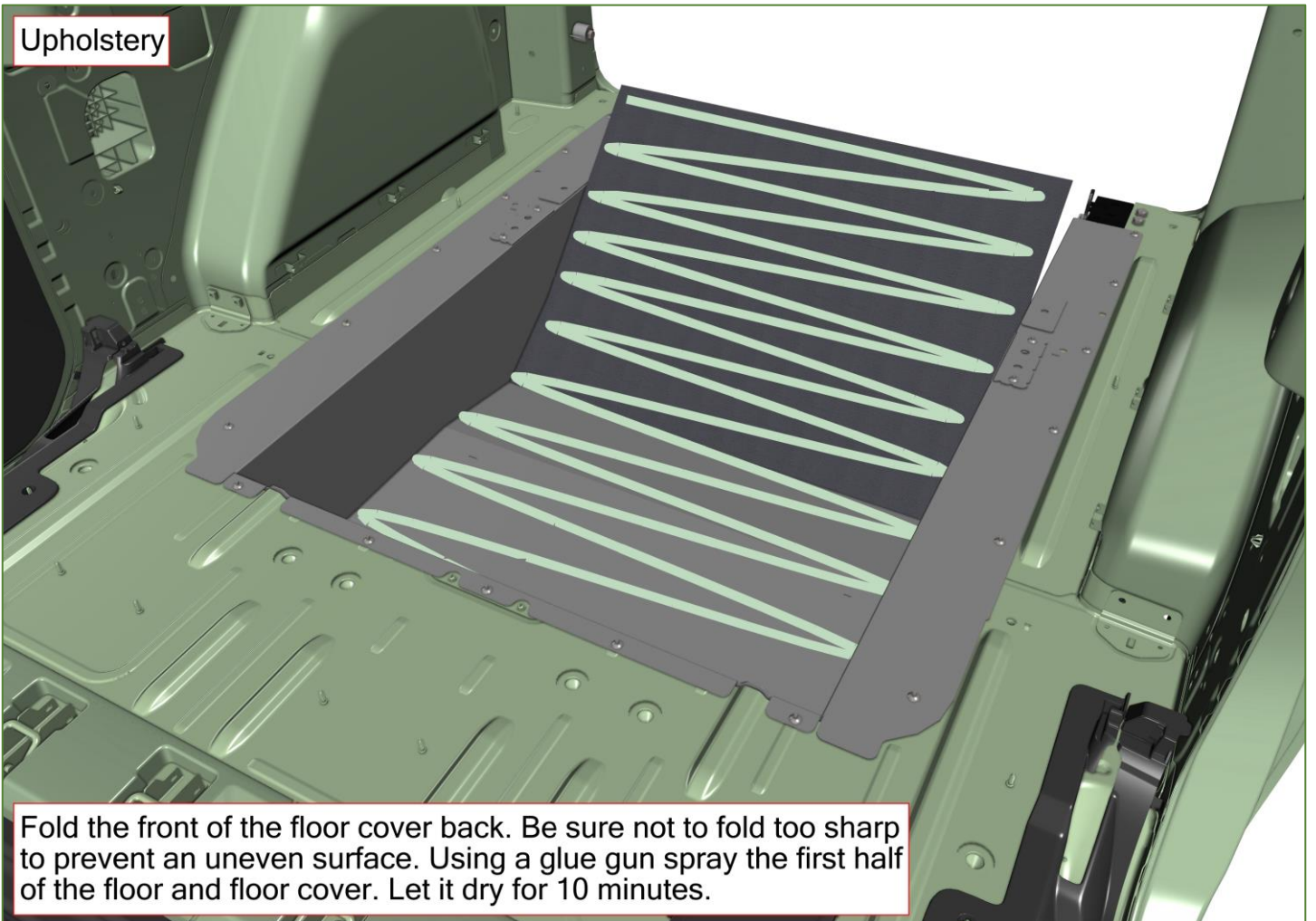

Fold the front of the floor cover back. Be sure not to fold too sharp to prevent an uneven surface. Using a glue gun spray the first half of the floor and floor cover. Let it dry for 10 minutes.



## Upholstery

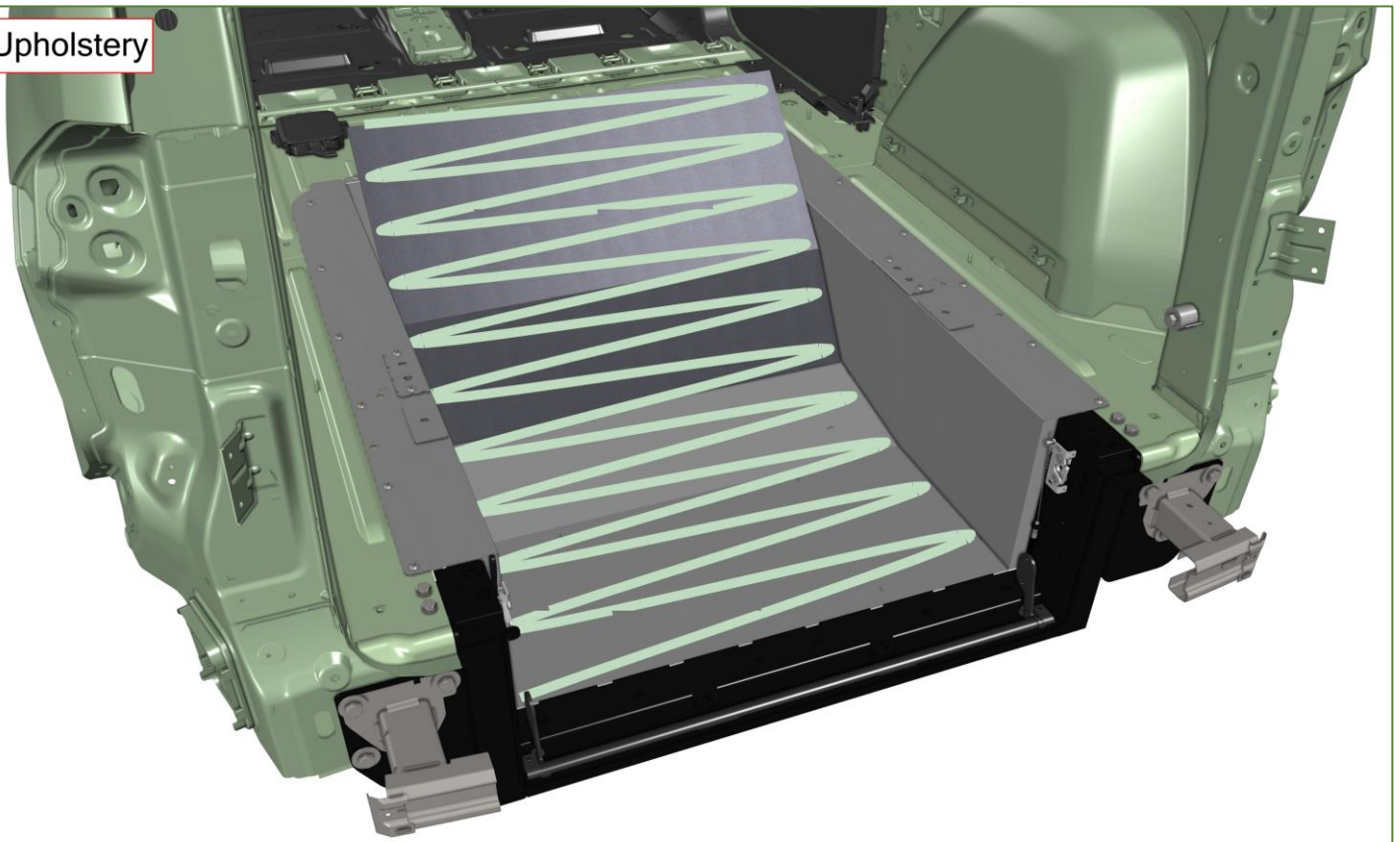

Fold the back of the floor cover to the front. Be sure not to fold too sharp to prevent uneven surface. Using a glue gun spray the rear half of the floor and floor cover. Let it dry for 10 minutes.

## Upholstery

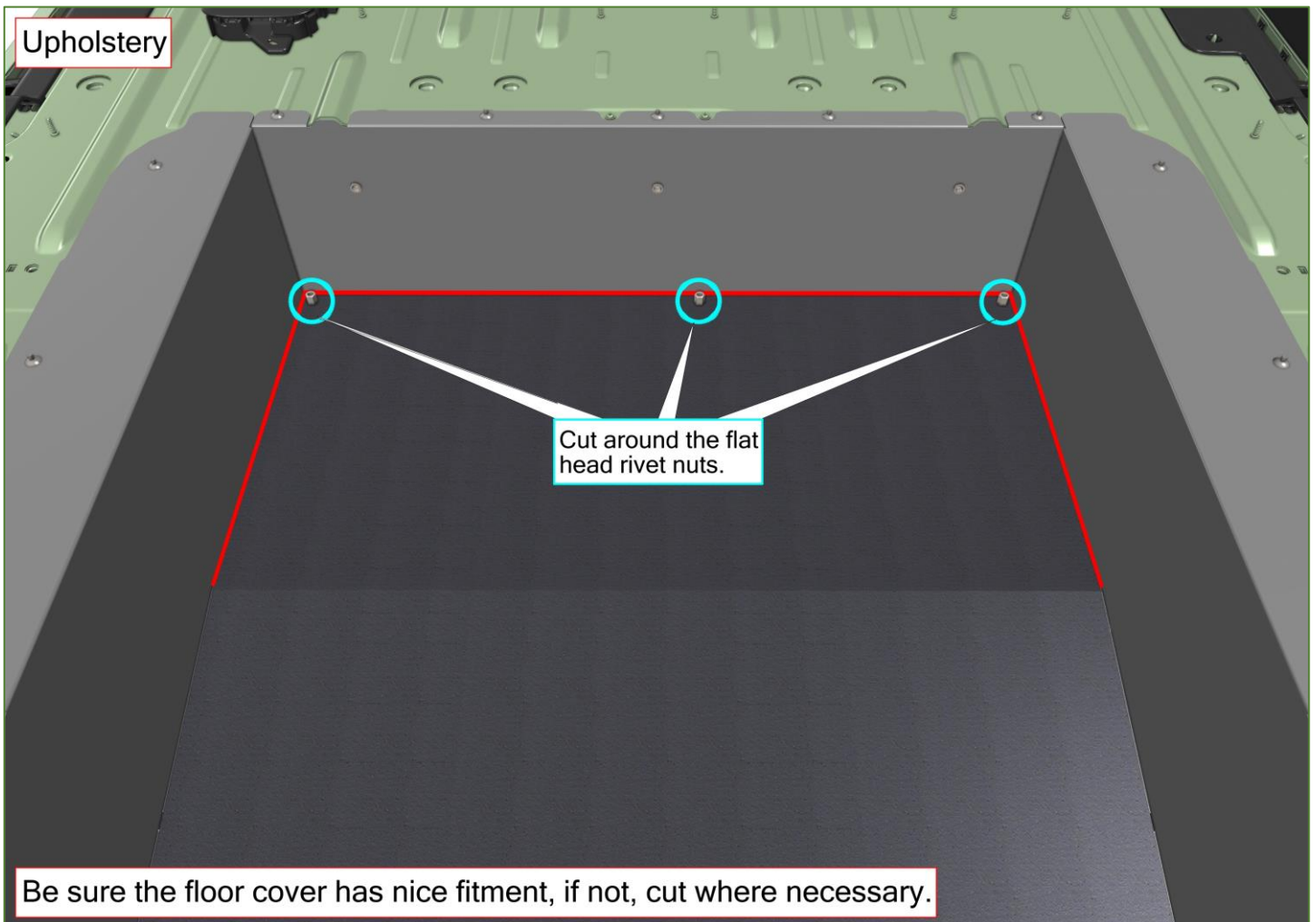

Be sure the floor cover has nice fitment, if not, cut where necessary.



Upholstery



Cut off any of the floor cover that might extend over this edge.

Make sure the floor has no gas bubbles.

Upholstery

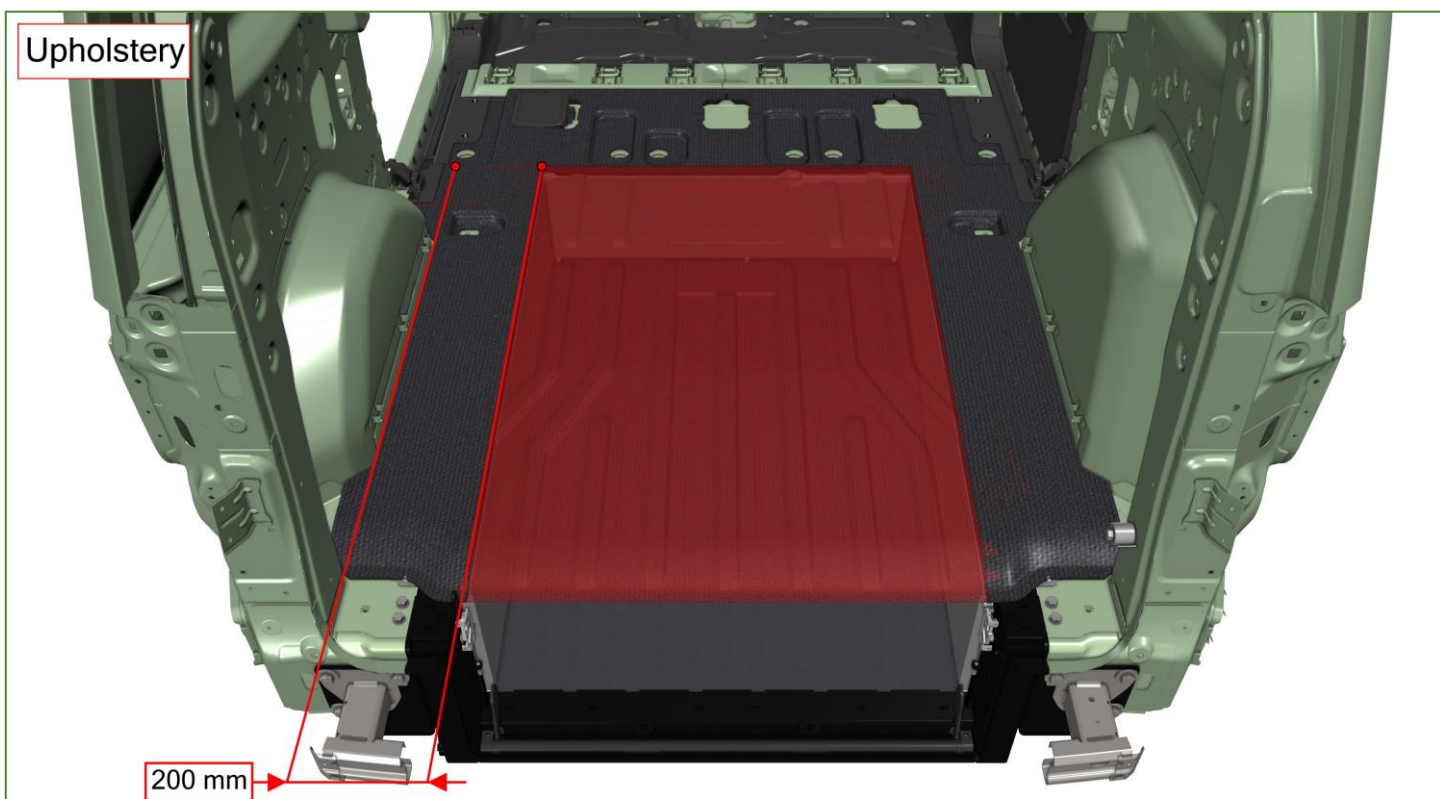

200 mm

Cut the floor mat as shown.

## Upholstery

Leave an edge about 5 cm up against the wheelarches. This will help getting a cleaner look once the interior panels are placed.

6827

Use a hole saw to make holes for the TriflexAir seat brackets. ONLY in case of TriflexAir seats.

Spray the sides and the OEM floor mat with the glue gun. Place the upholstery and cut to size.

## Floor LED install

In case of the floor LED lights, cut out the rectangle openings to make the LED lights fit. Be careful to not cut the wires behind the upholstery.



Floor LED install

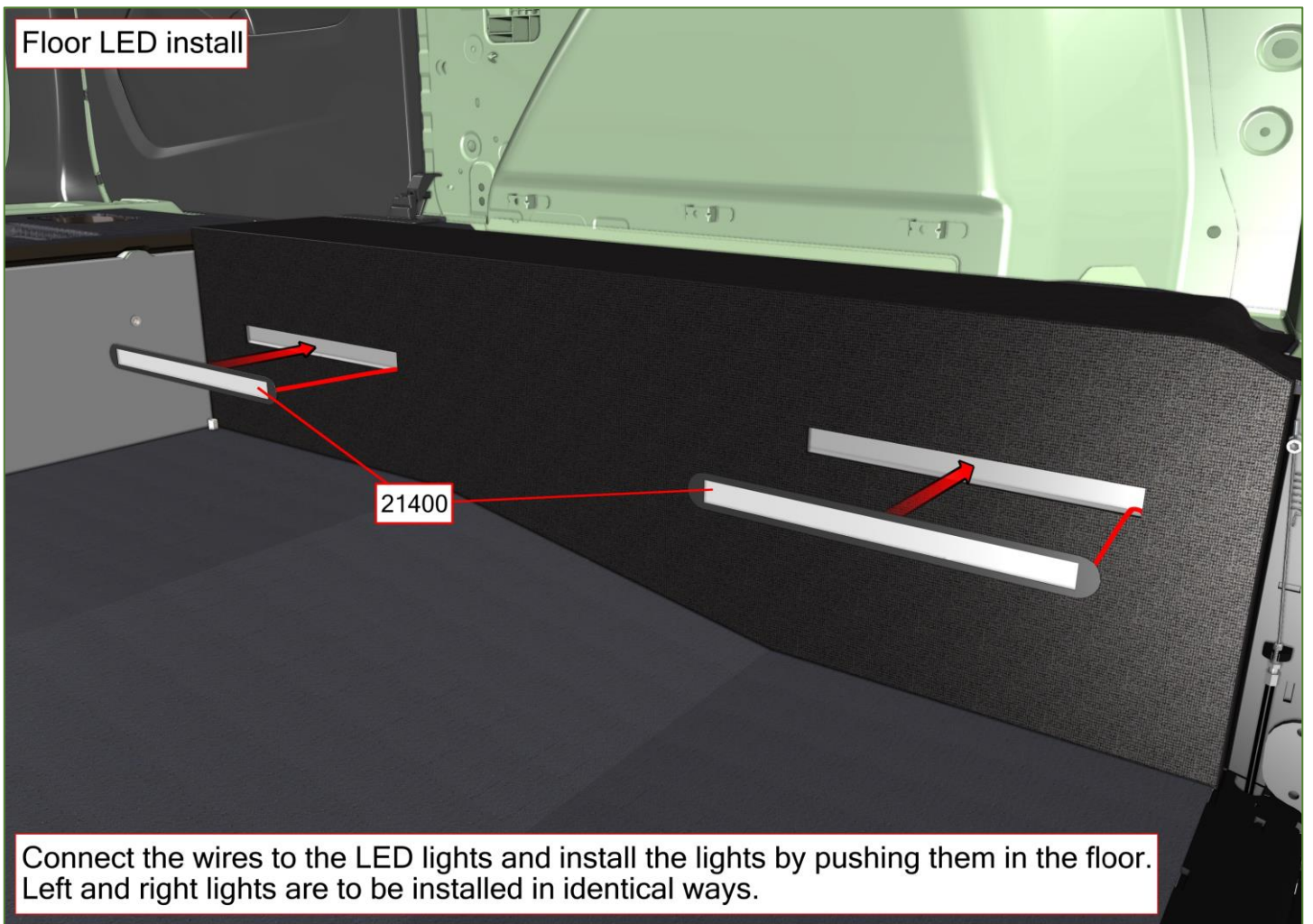

Connect the wires to the LED lights and install the lights by pushing them in the floor. Left and right lights are to be installed in identical ways.

Floor LED install

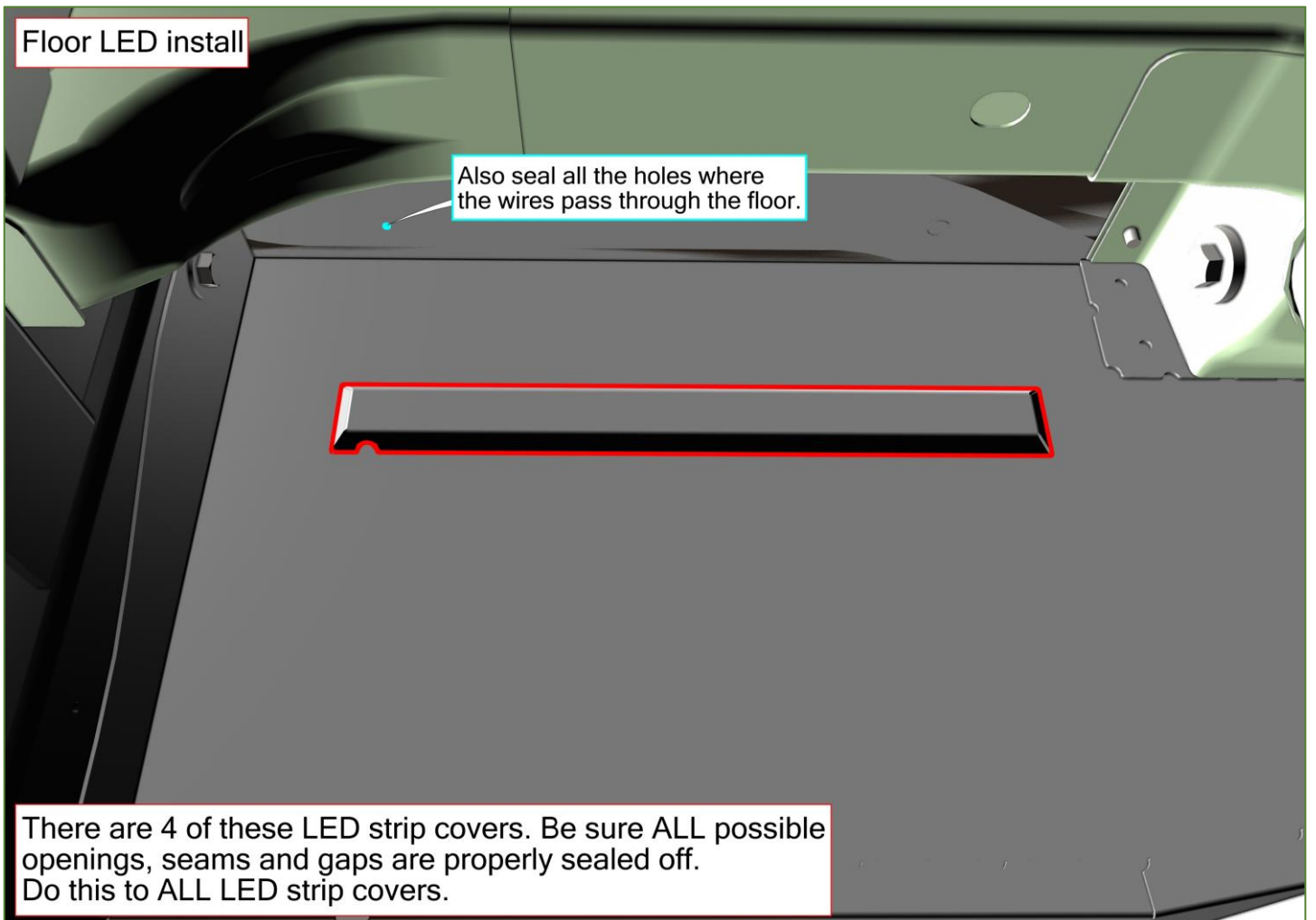

There are 4 of these LED strip covers. Be sure ALL possible openings, seams and gaps are properly sealed off. Do this to ALL LED strip covers.



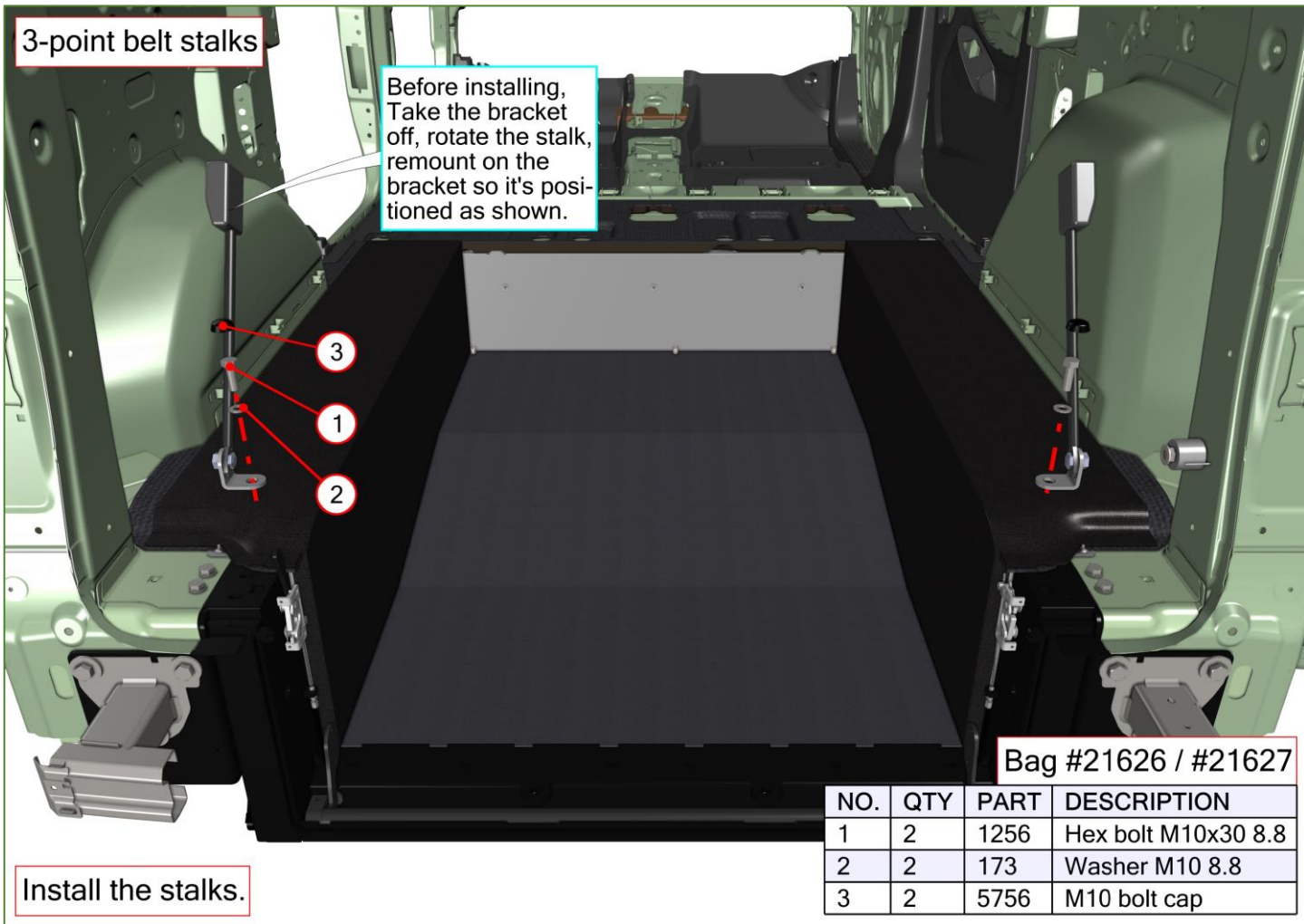

Front retractors

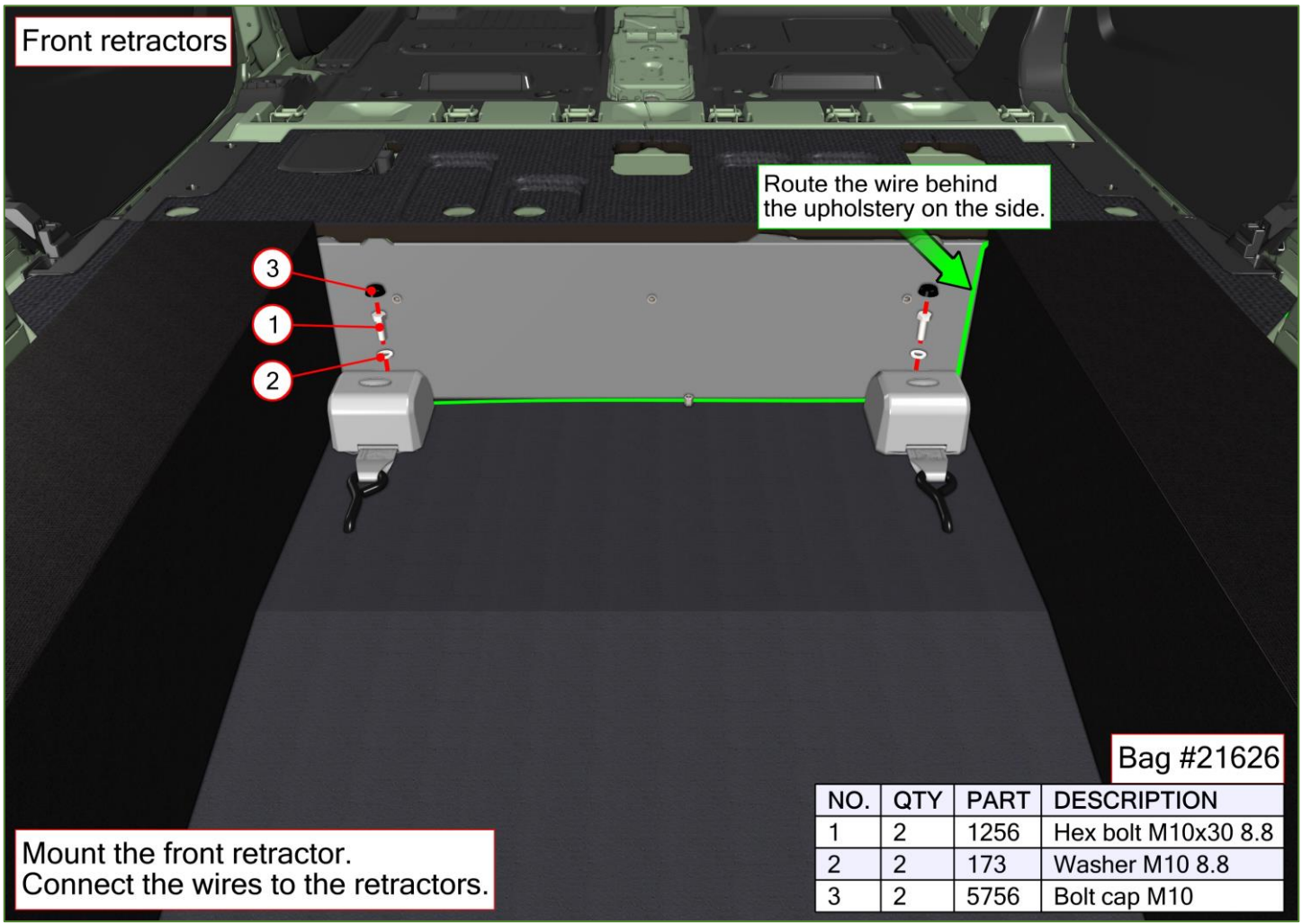

Mount the front retractor.  
Connect the wires to the retractors.

Bag #21626

NO.	QTY	PART	DESCRIPTION
1	2	1256	Hex bolt M10x30 8.8
2	2	173	Washer M10 8.8
3	2	5756	Bolt cap M10

Front retractors

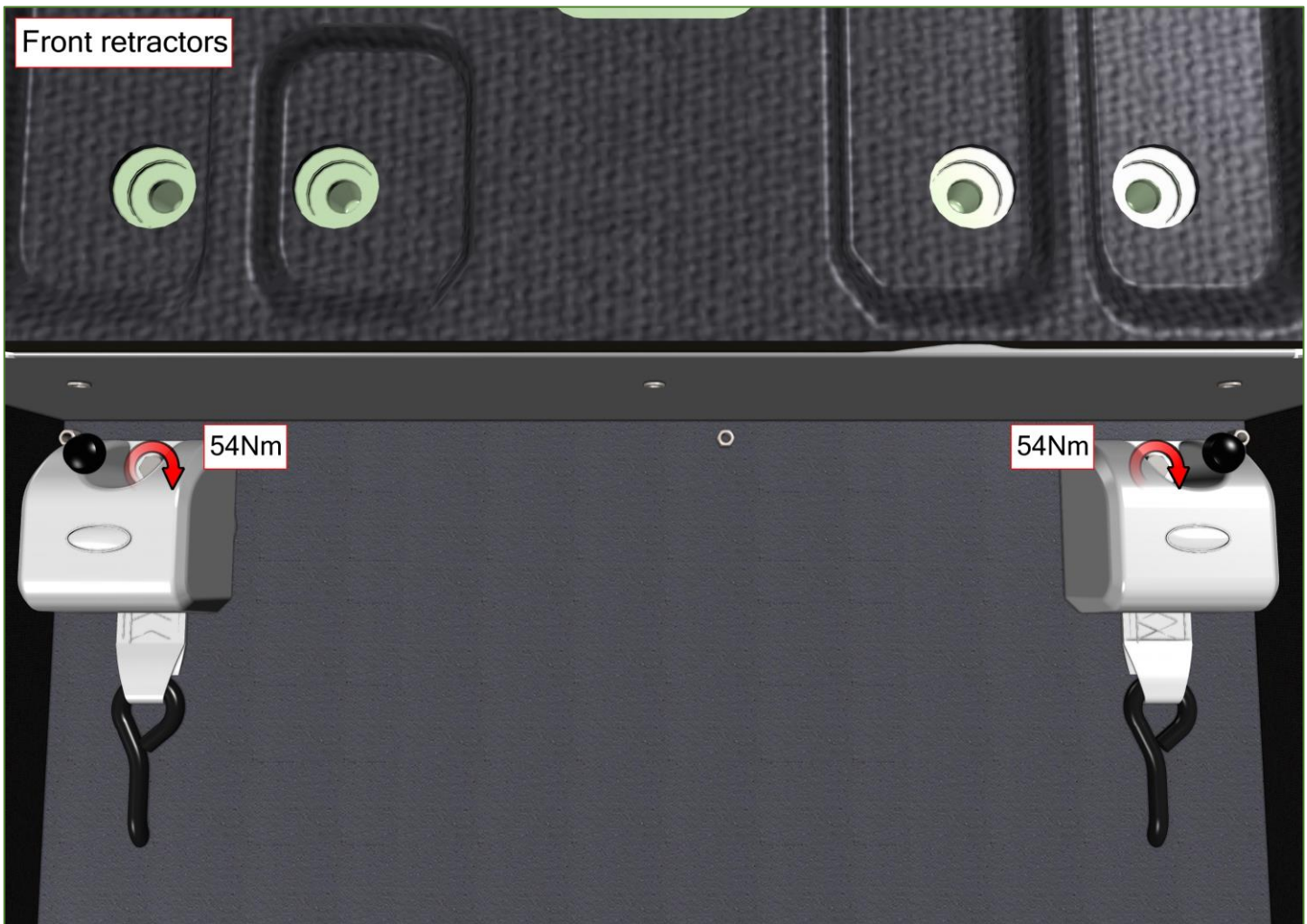

54Nm

54Nm



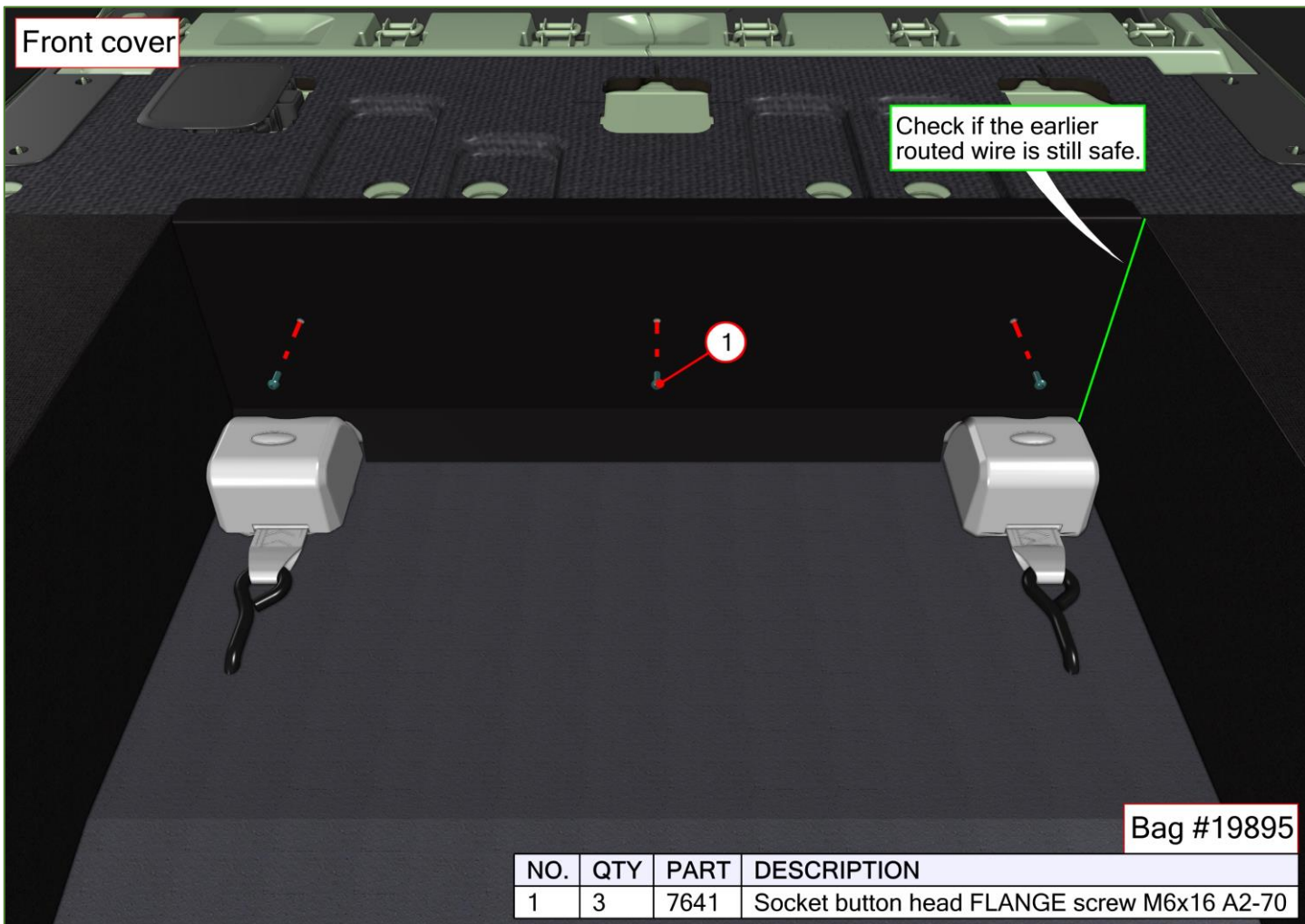
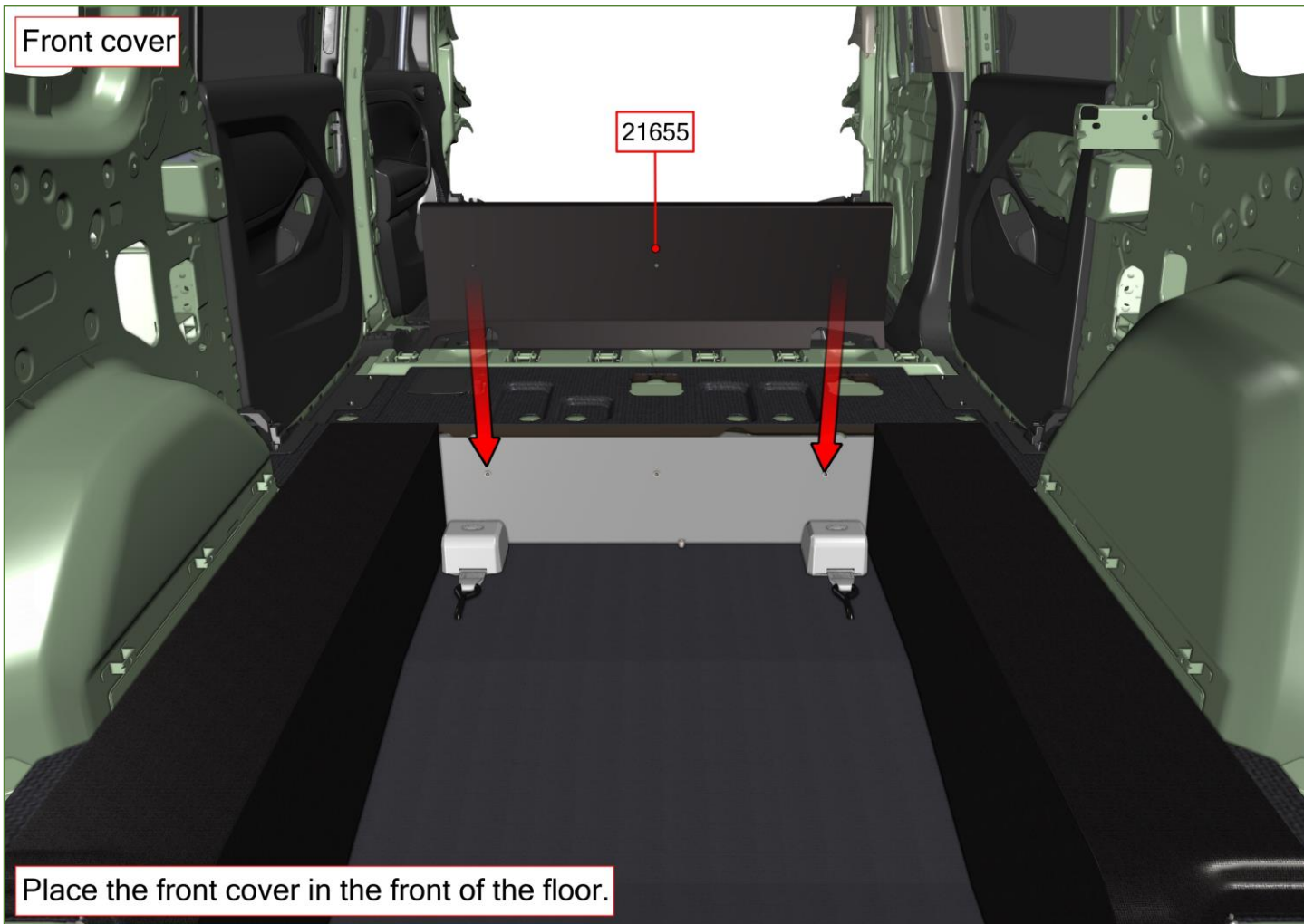



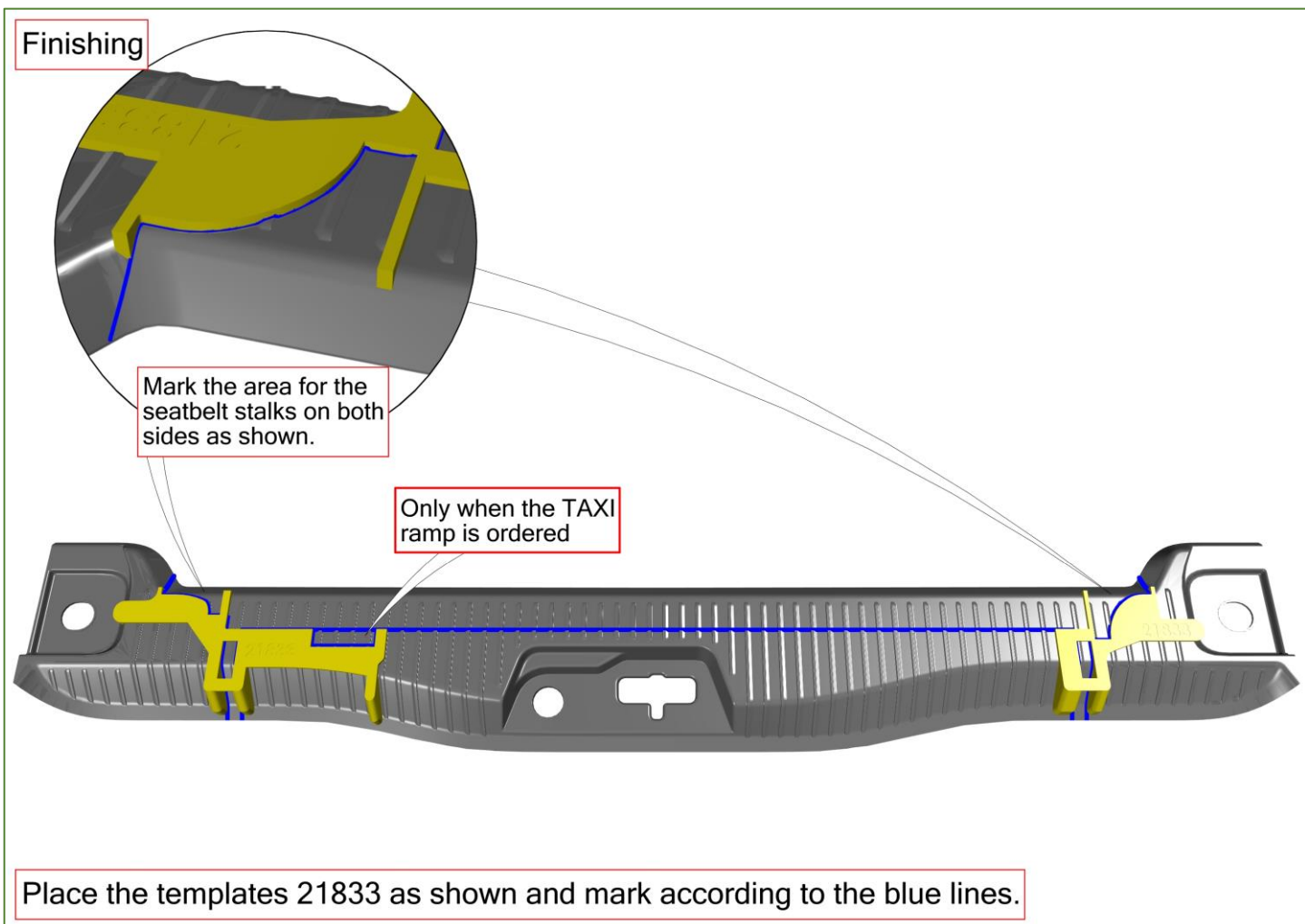
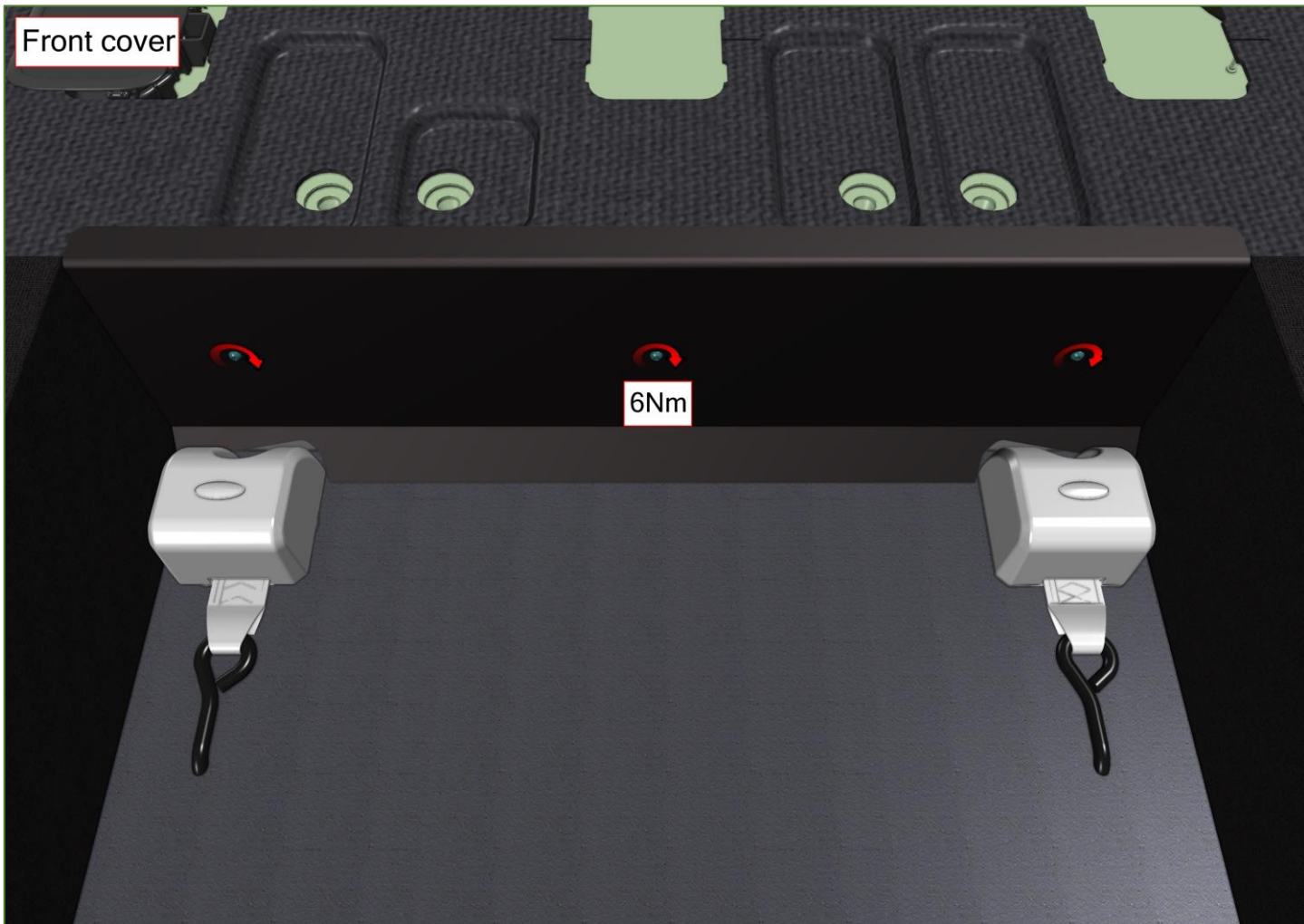

Finishing

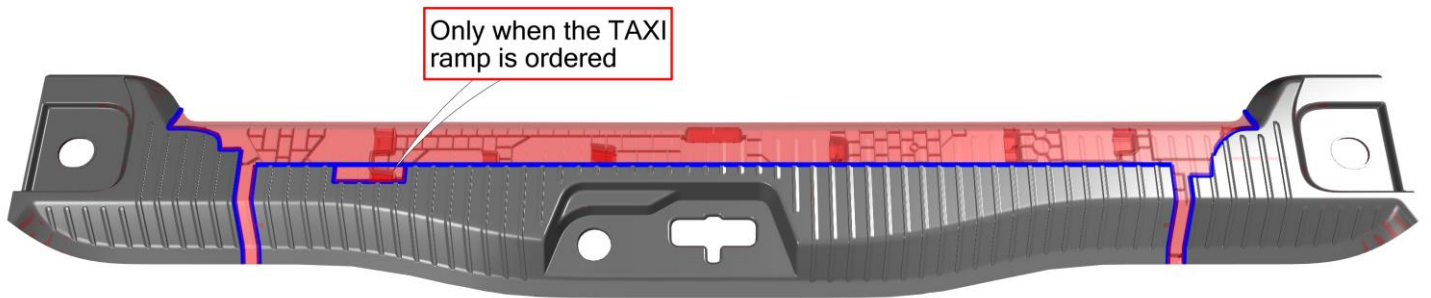

Cut along the markings.

Finishing

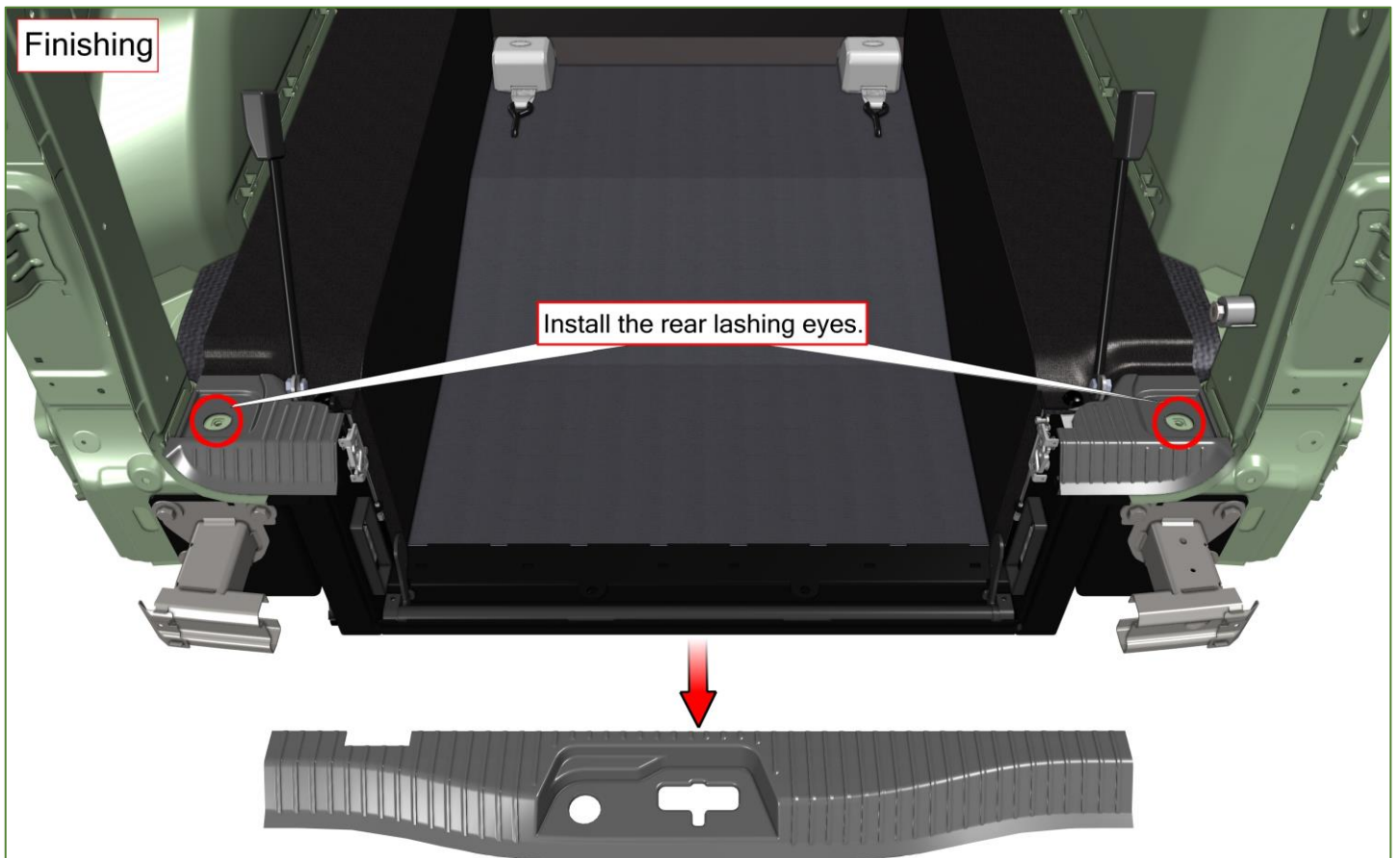

Install the rear sill, keep the middle part.  
Remove the ridges on the bottom of the sill if they prevent good fitment.

Finishing

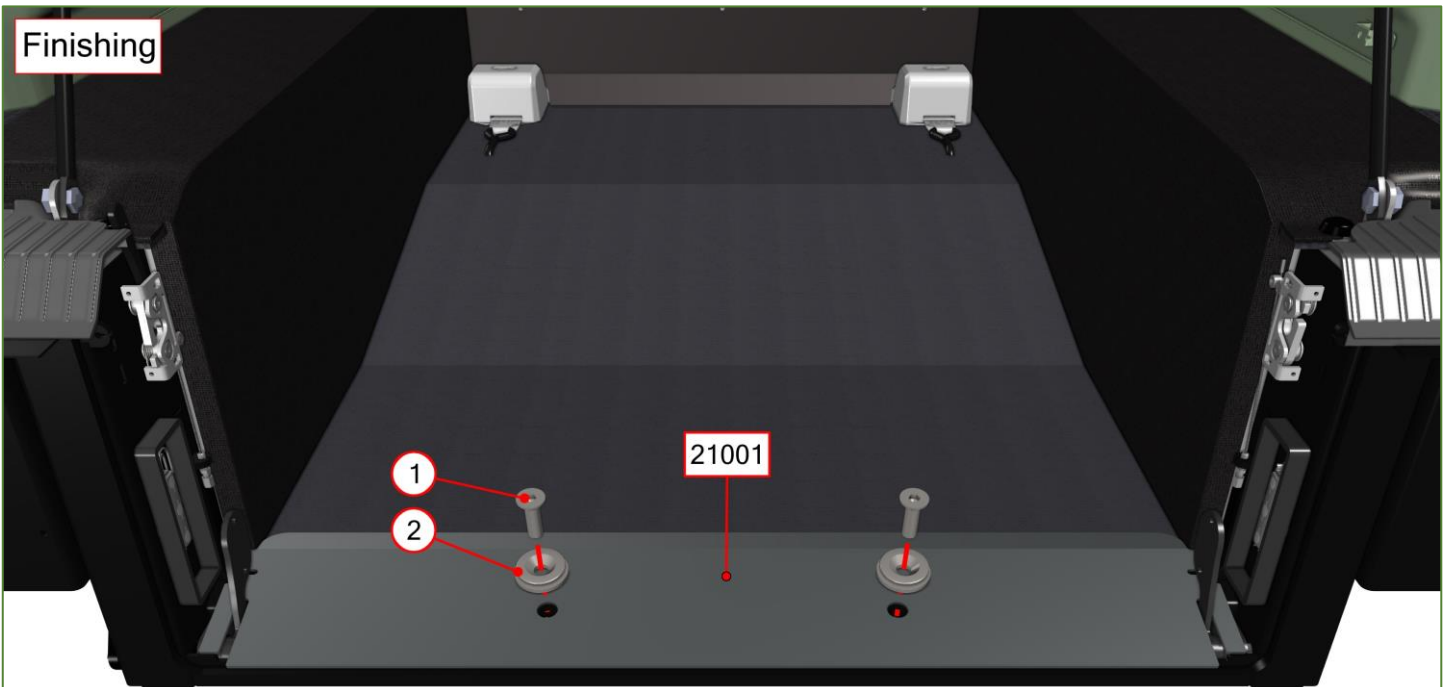

Bag #20999

Install the rear cover.

NO.	QTY	PART	DESCRIPTION
1	2	5795	Socket countersunk head screw M12x40 10.9
2	2	5562	Triplock, floor part

Finishing

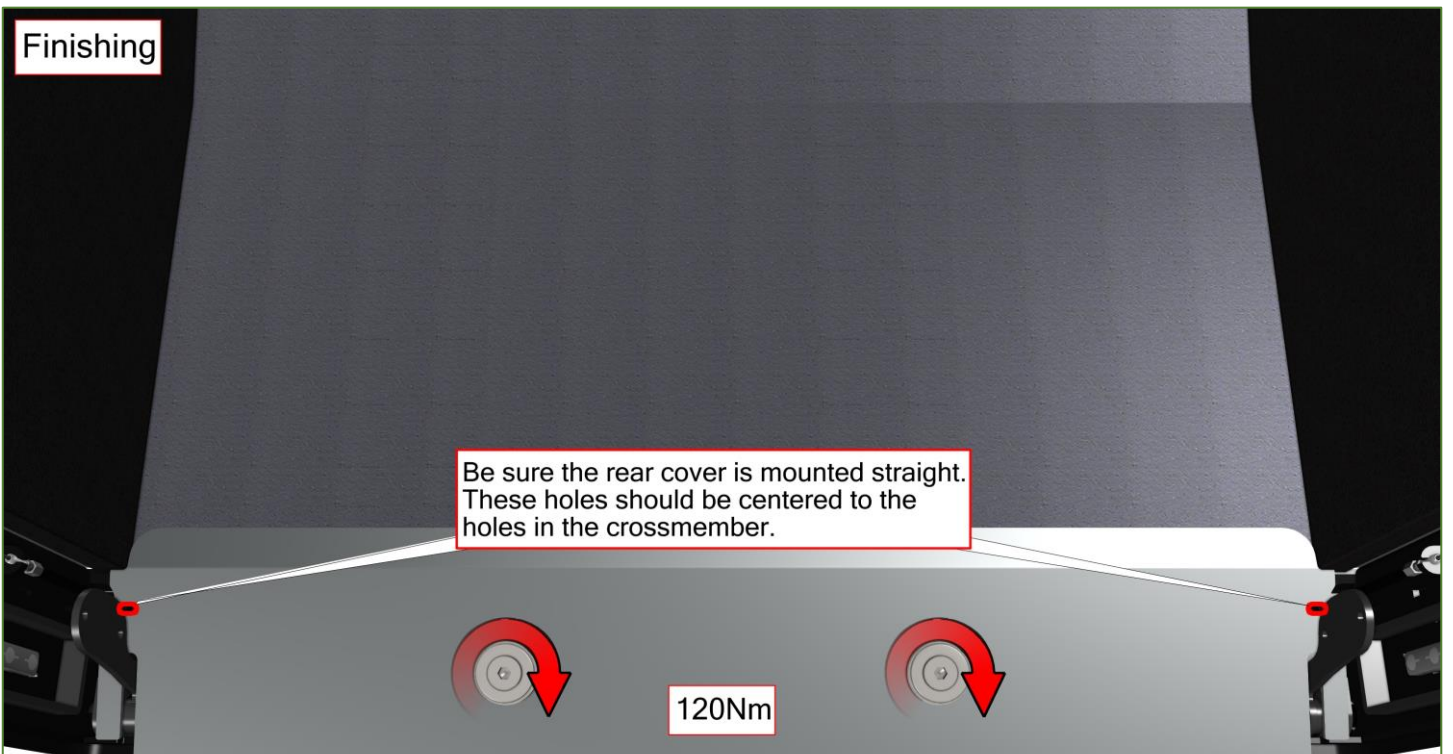



Finishing

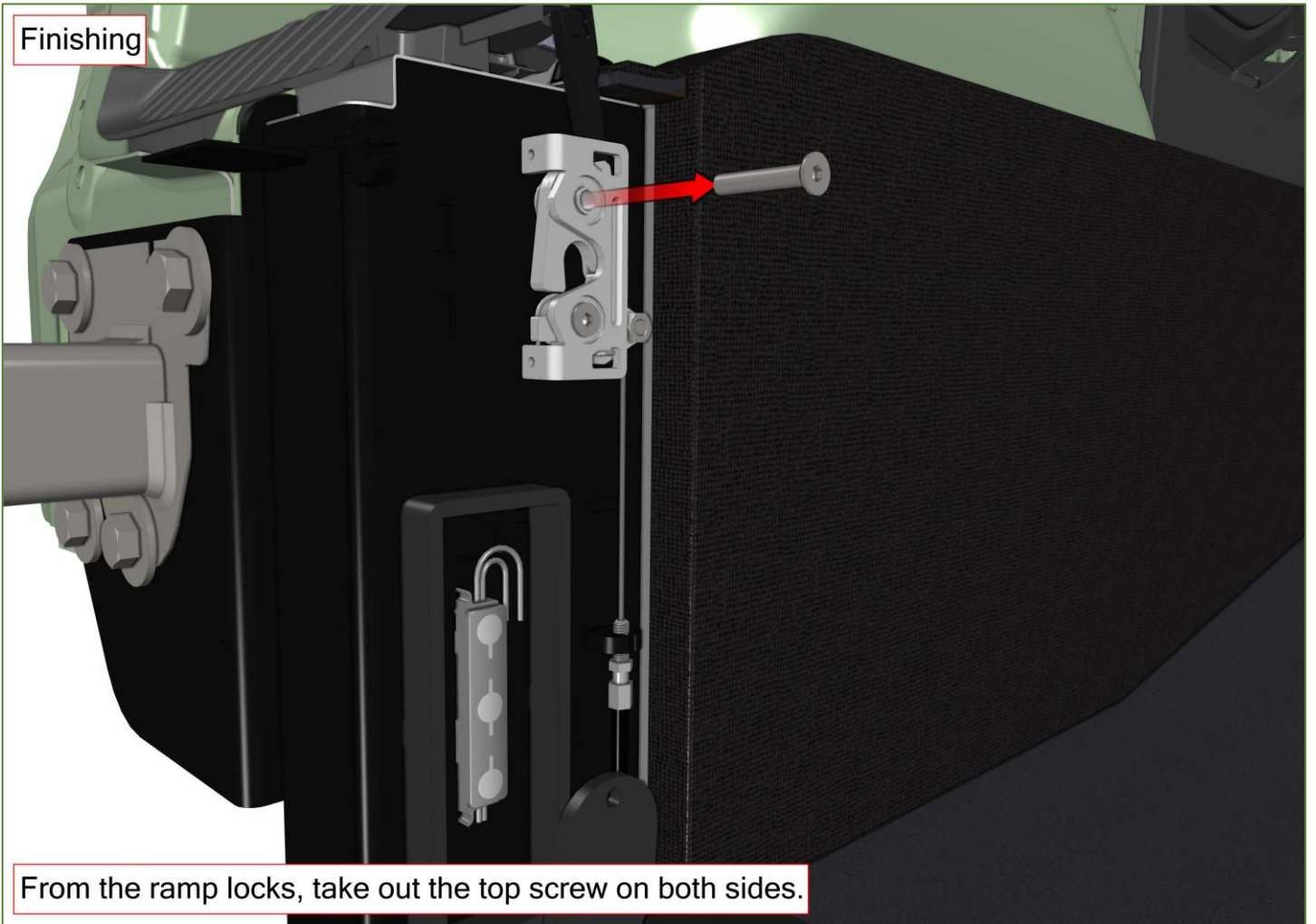

From the ramp locks, take out the top screw on both sides.

Finishing

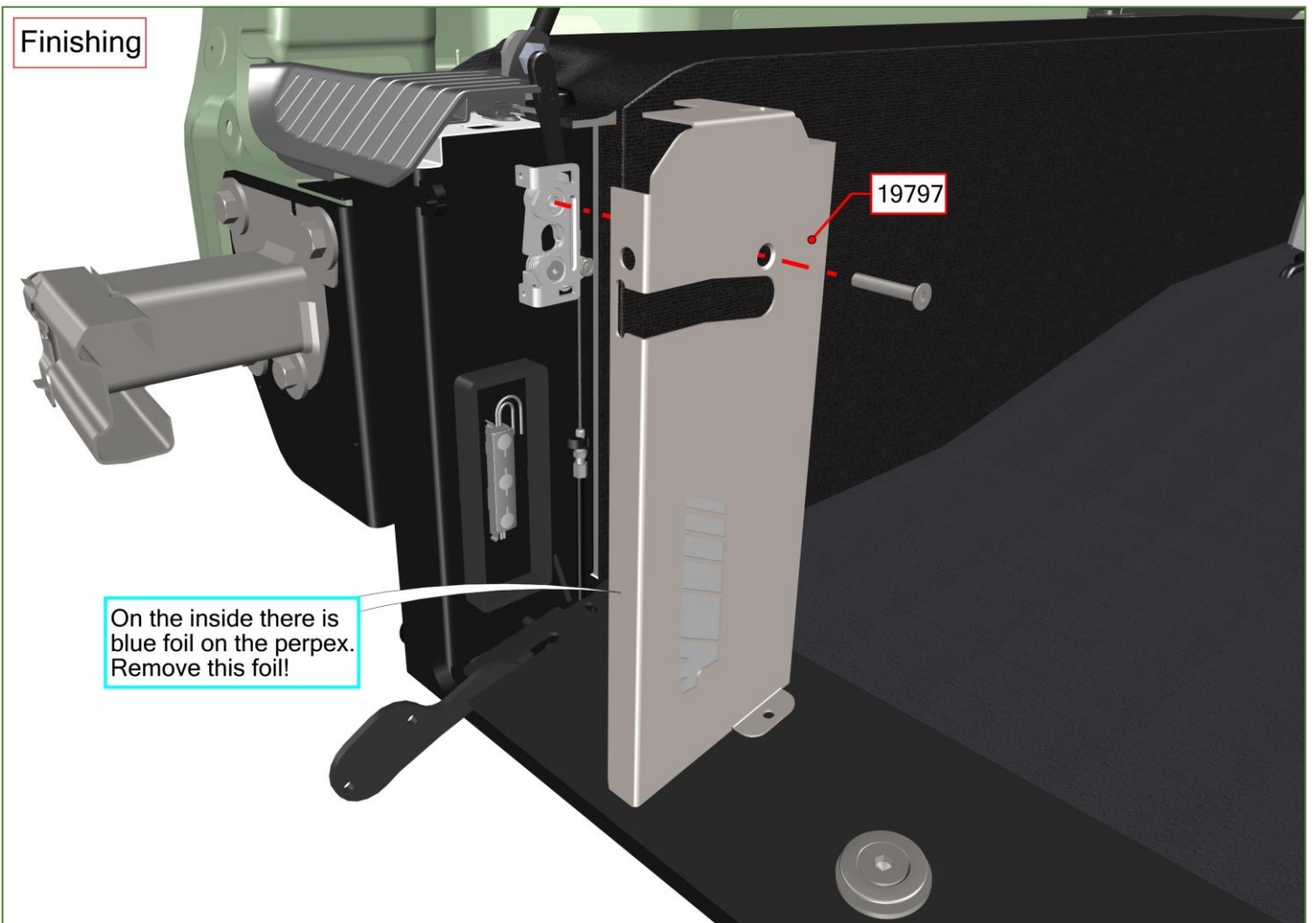

On the inside there is blue foil on the perpex. Remove this foil!

Finishing

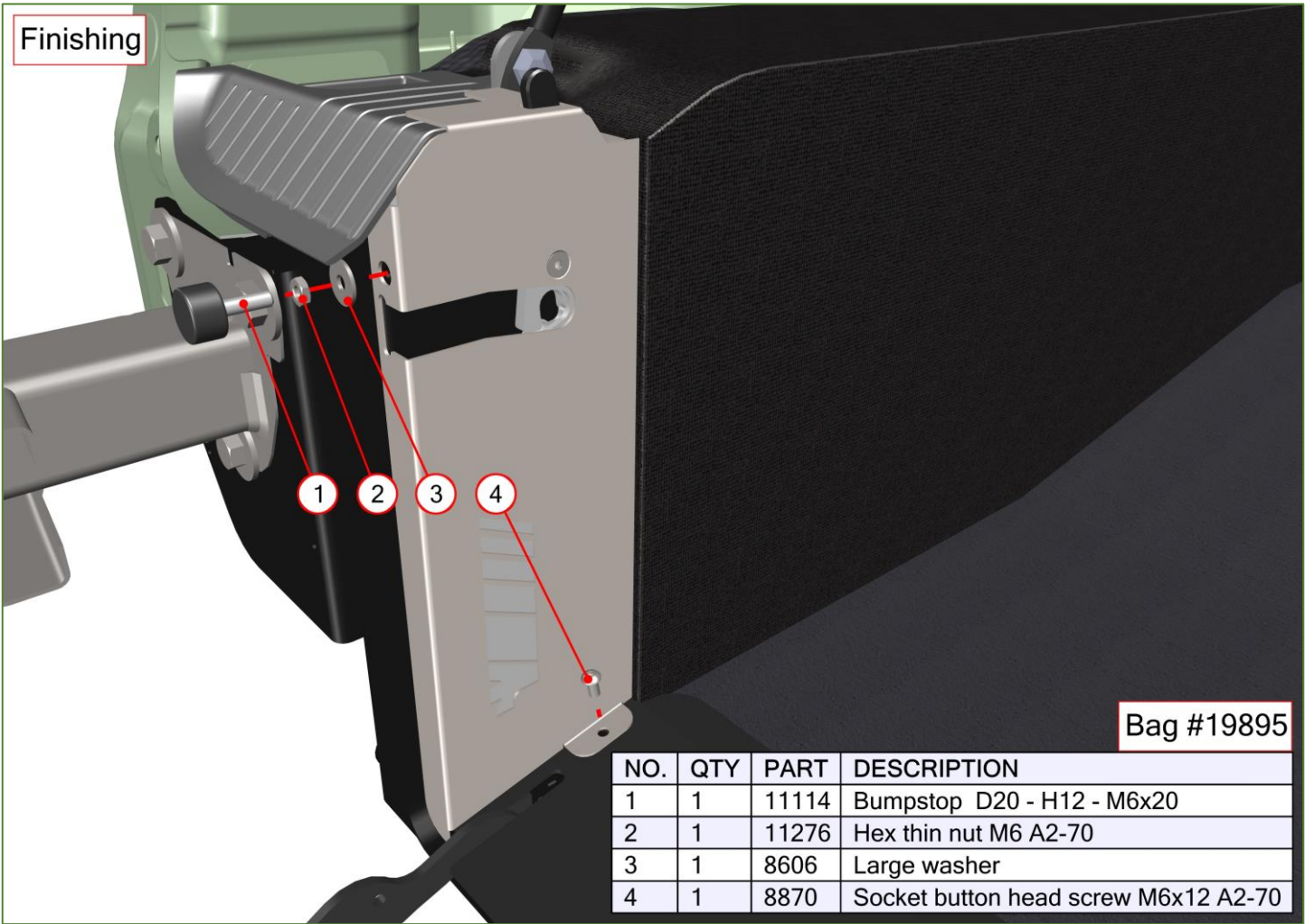

Bag #19895

NO.	QTY	PART	DESCRIPTION
1	1	11114	Bumpstop D20 - H12 - M6x20
2	1	11276	Hex thin nut M6 A2-70
3	1	8606	Large washer
4	1	8870	Socket button head screw M6x12 A2-70

Finishing

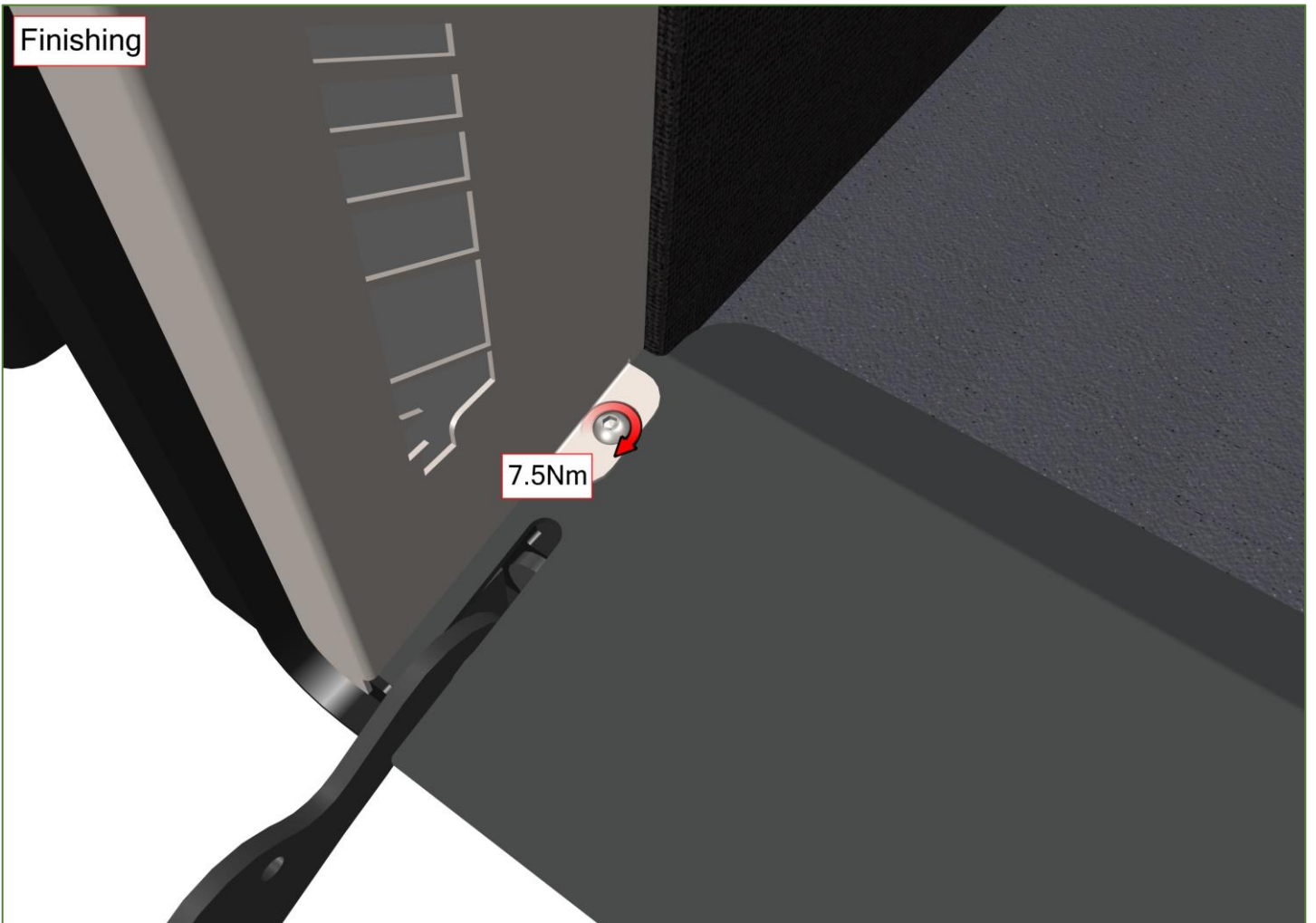

## Finishing

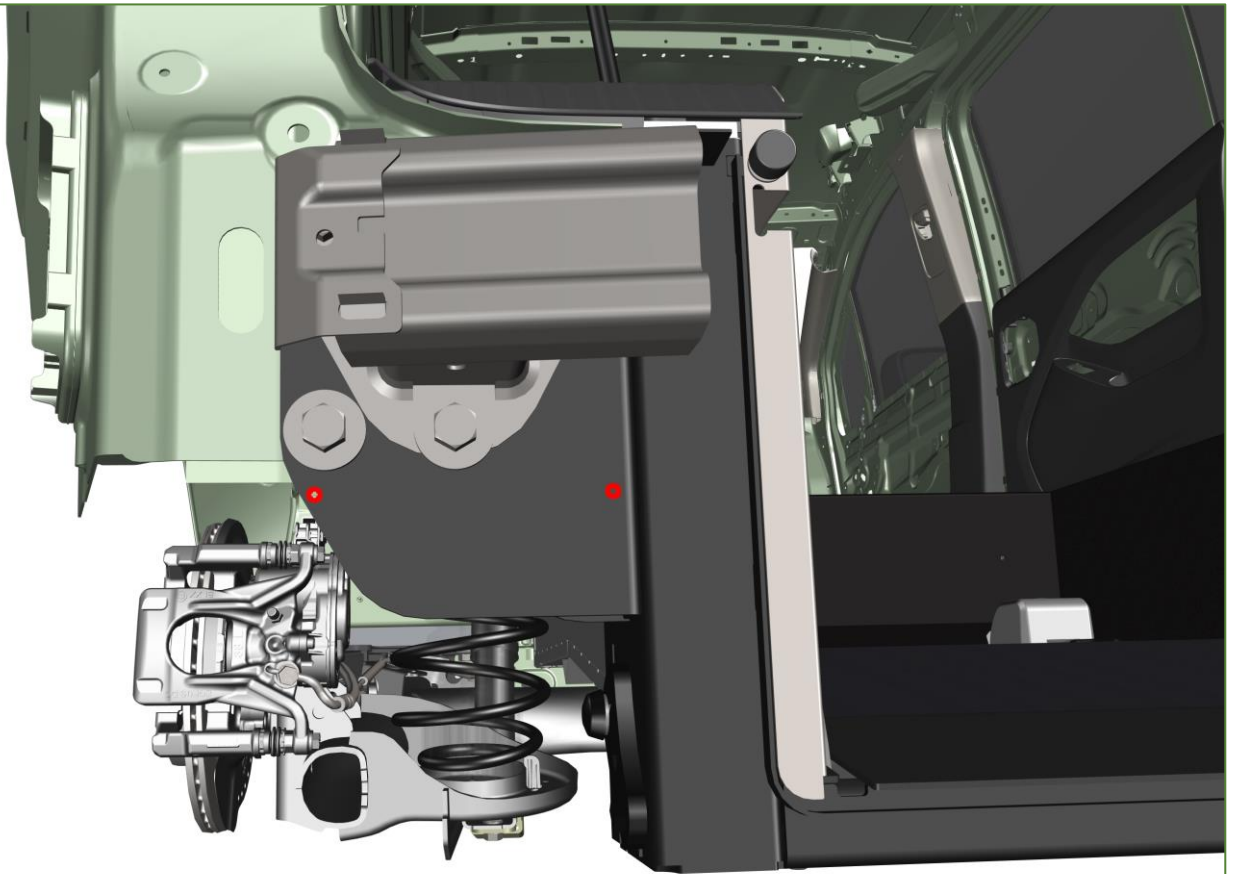

On the left side there are 2 small threaded holes.  
This is where the keyless entry unit will be mounted.  
Mount using 2 M6 socket button head screws and M6 washers.

## Parking sensors

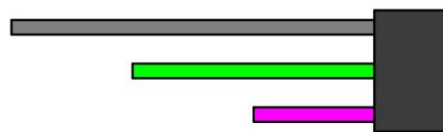

Be sure to cut the wires at different lengths.  
Keep enough wire on the sensor and on the  
wiring loom to prevent problems when  
connecting the tripod wires.

Take the parking sensor wiring out of the rear bumper.  
Cut off the middle 2 sensors.



## Parking sensors

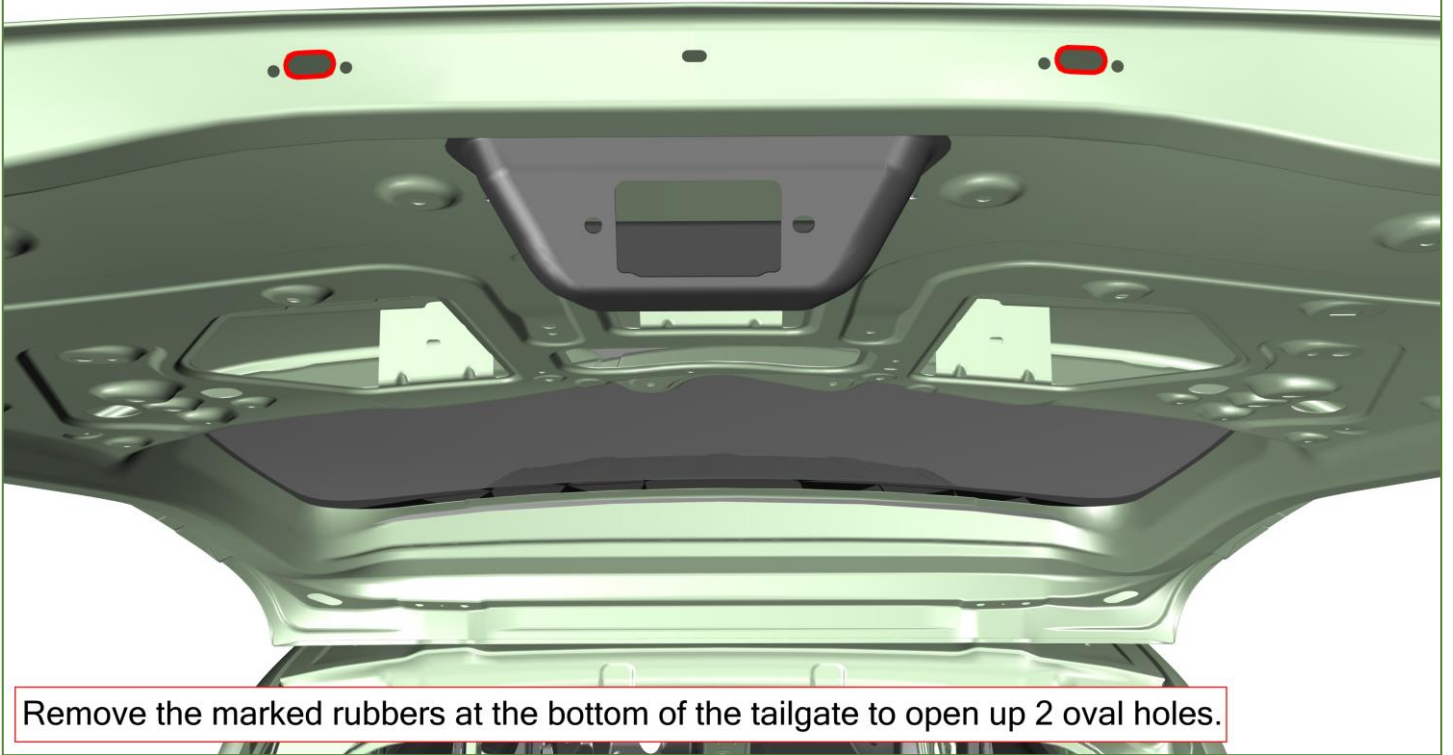

## Parking sensors



Pull the cables through these holes.  
Apply a grommet (Partno. 3540) in the oval holes.

Keep the cables on the inside.

Route the cables through  
the grommet connecting  
the tailgate.

Route the cables down  
the inside of the D-pillar.

Route the cables through  
the rubber at the bottom  
of the D-pillar.

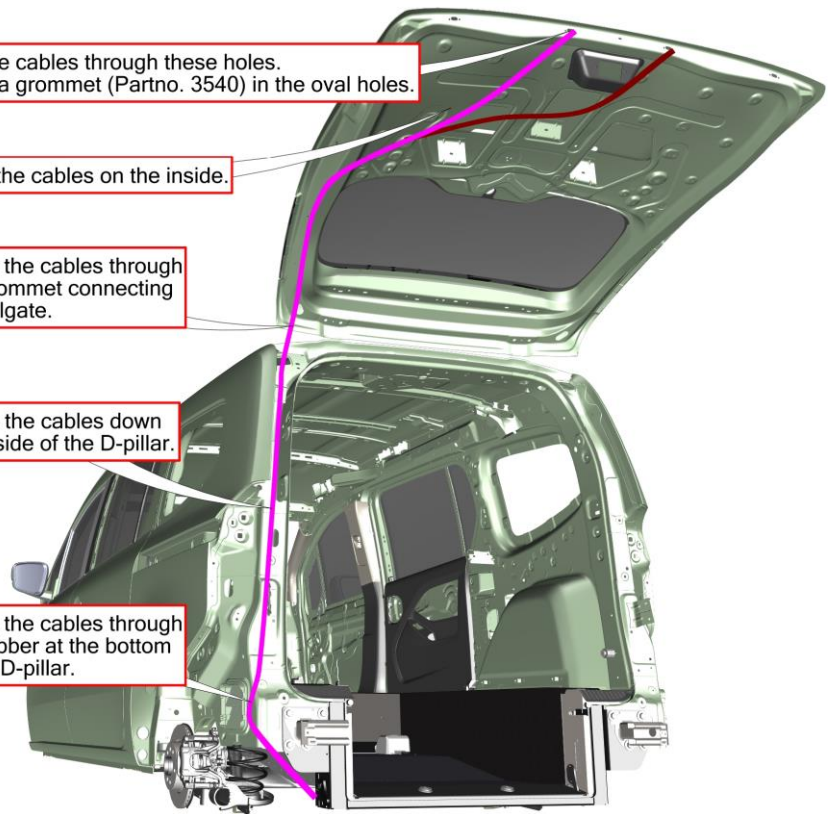

Connect the middle 2 sensors to the extension cables.  
Purple -> left  
Brown -> right

Parking sensors

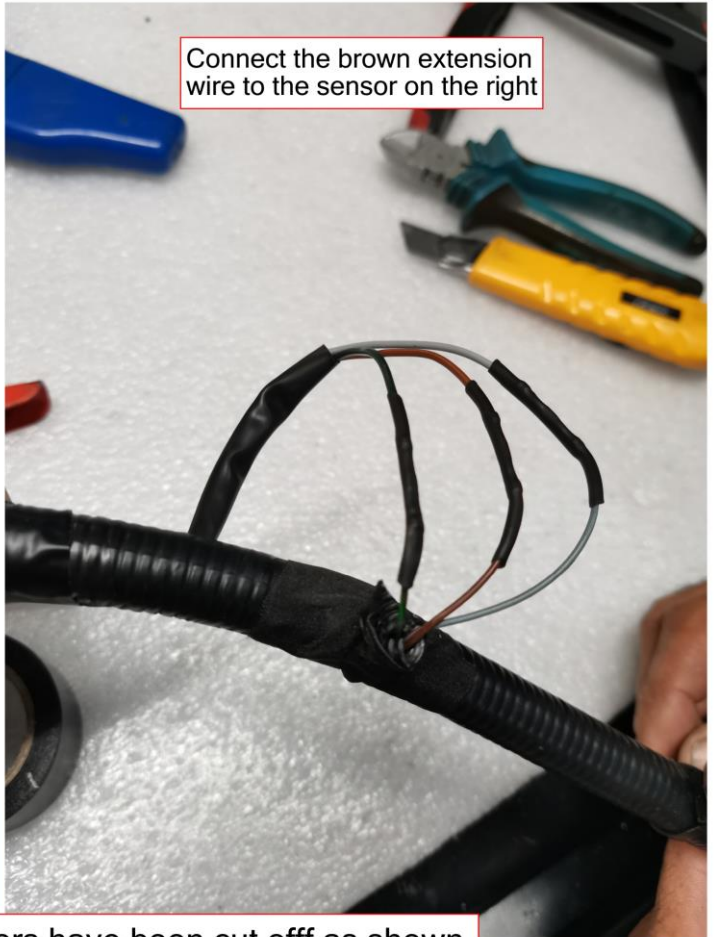
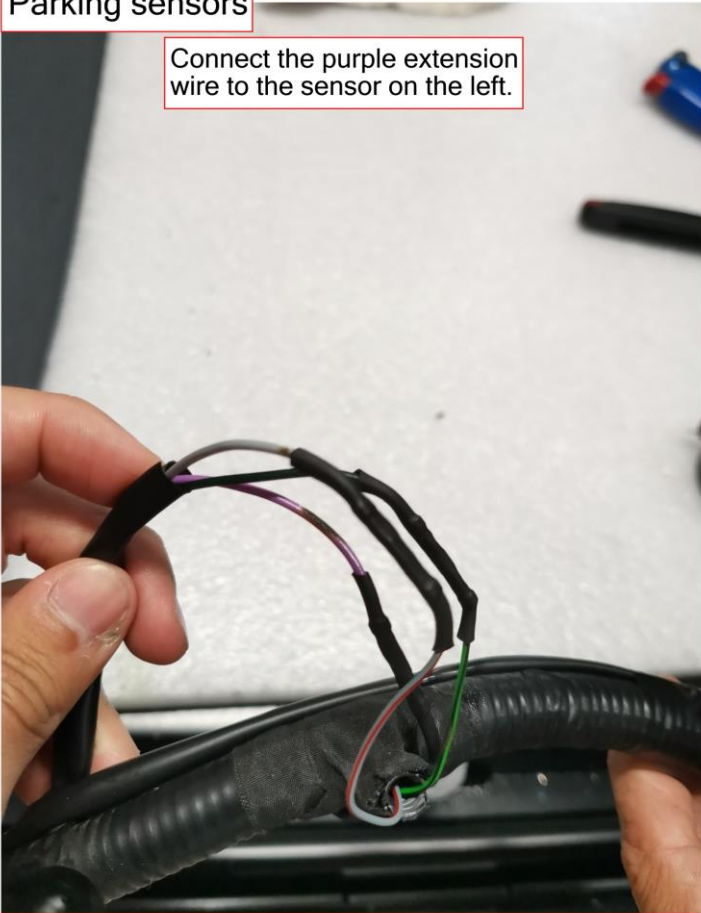

Connect the extension wires to where the sensors have been cut off as shown.

Parking sensors

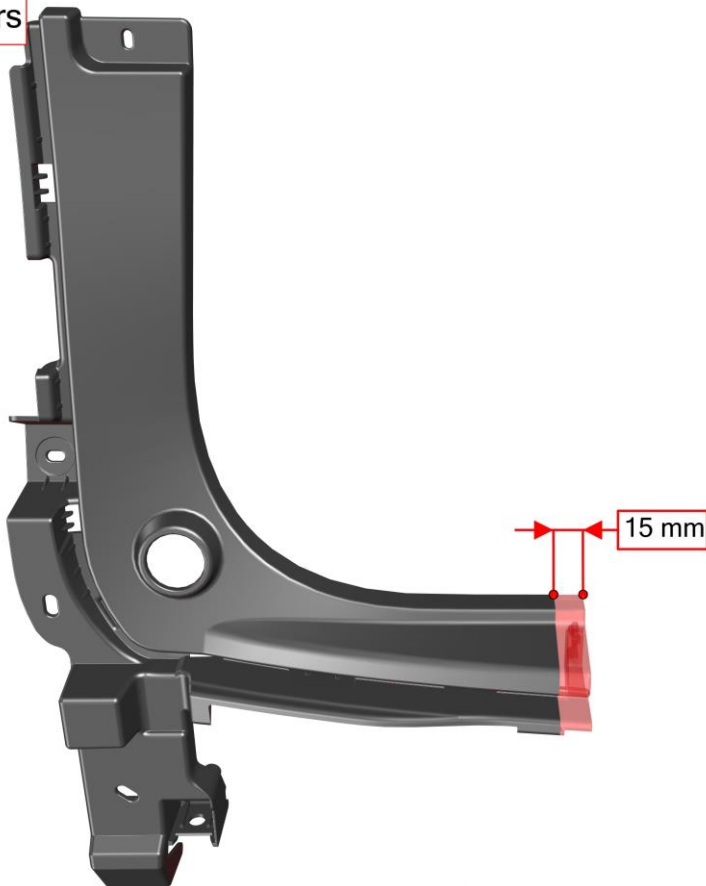

Cut 15mm off the bumper strip corner pieces. Both the left and right piece.



Parking sensors

Mount OEM bolt.

1

Bag #19892

Install the plastic rear bumper corner strips as shown.

NO.	QTY	PART	DESCRIPTION
1	1	1459	Pop rivet 4,8x12,7 alu/st

Parking sensors

Place the rear bumper on the vehicle. Mark the rear bumper 15mm on the outside of the upright edge on the back of the crossmember.



## Parking sensors

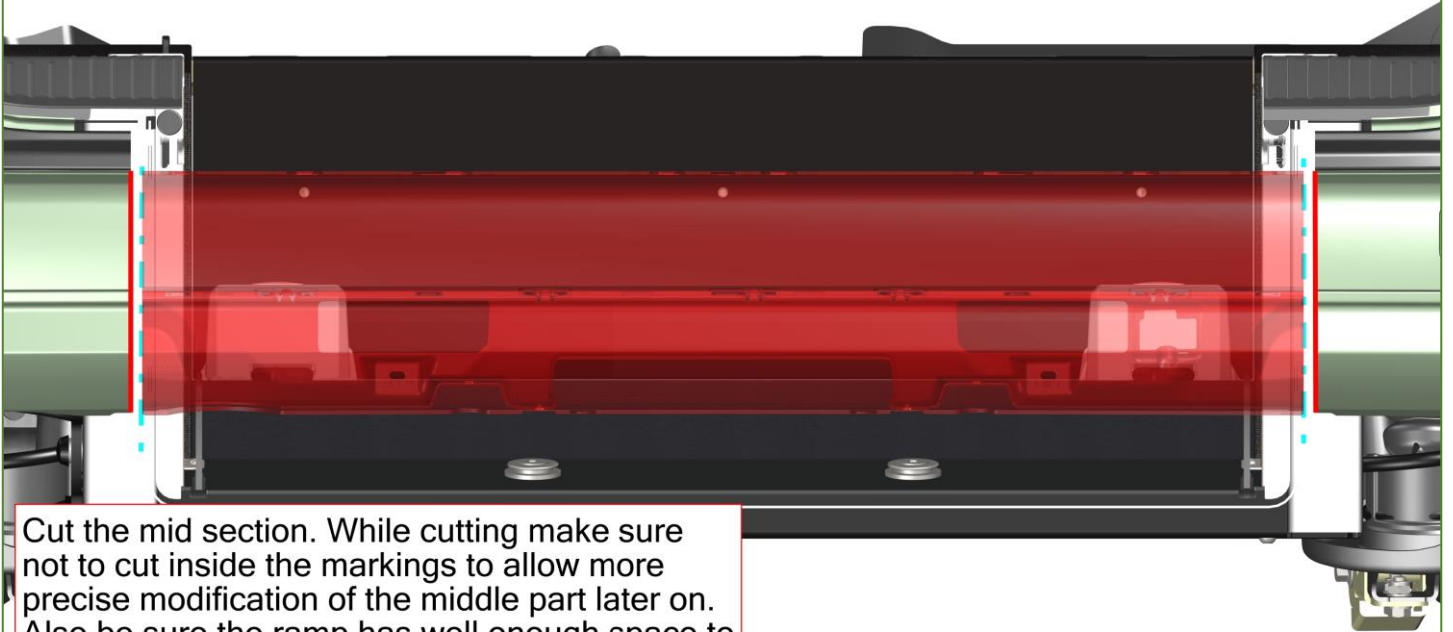

Cut the mid section. While cutting make sure not to cut inside the markings to allow more precise modification of the middle part later on. Also be sure the ramp has well enough space to open and close.

## Parking sensors

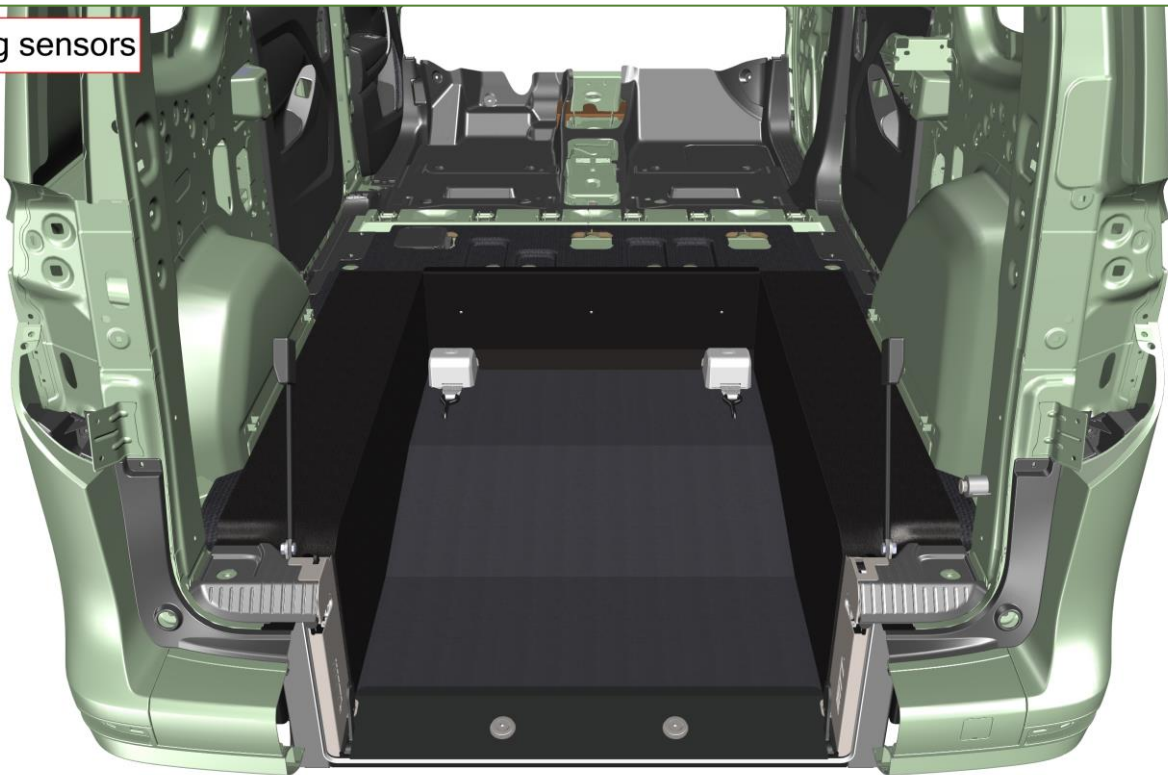

Keep the rear bumper on the vehicle.

## Parking sensors

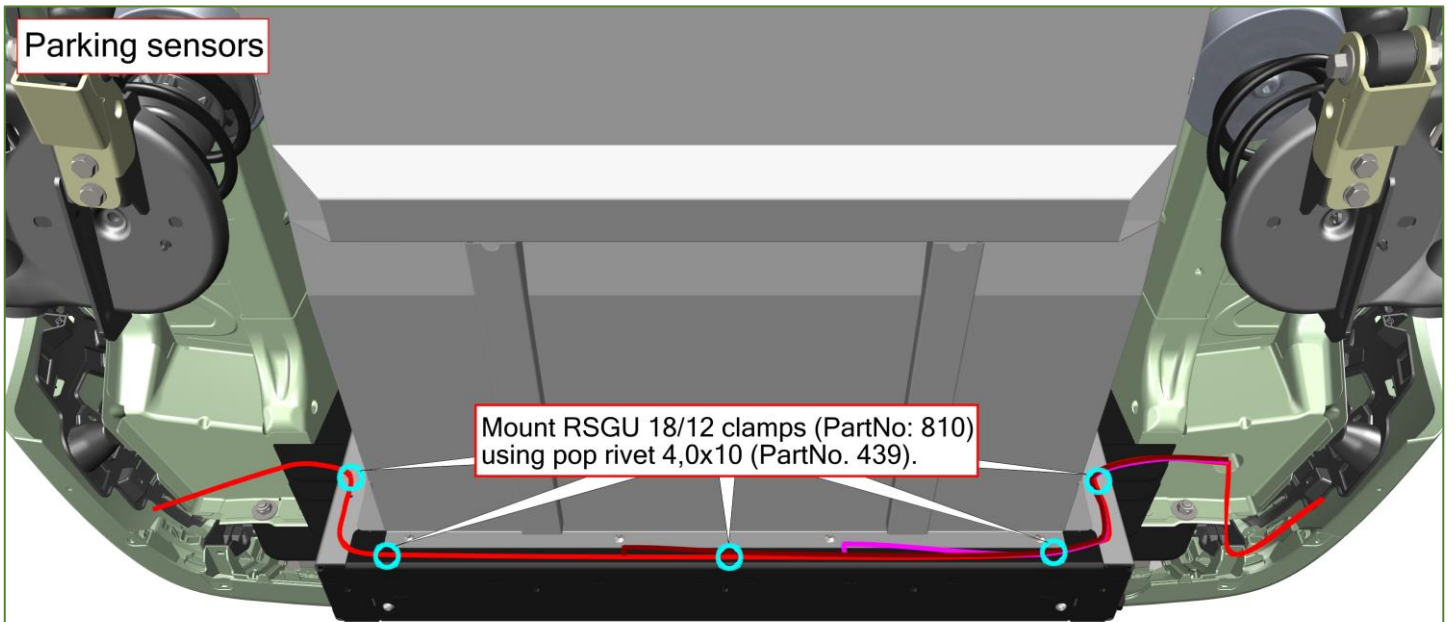

Mount RSGU 18/12 clamps (PartNo: 810) using pop rivet 4,0x10 (PartNo. 439).

Route the parking sensor wiring loom across the front side of the rear crossmember. Place the corner sensors back in the bumper. Wrap the cables in water resistant tape for proper protection against short circuit.

## Interior panels

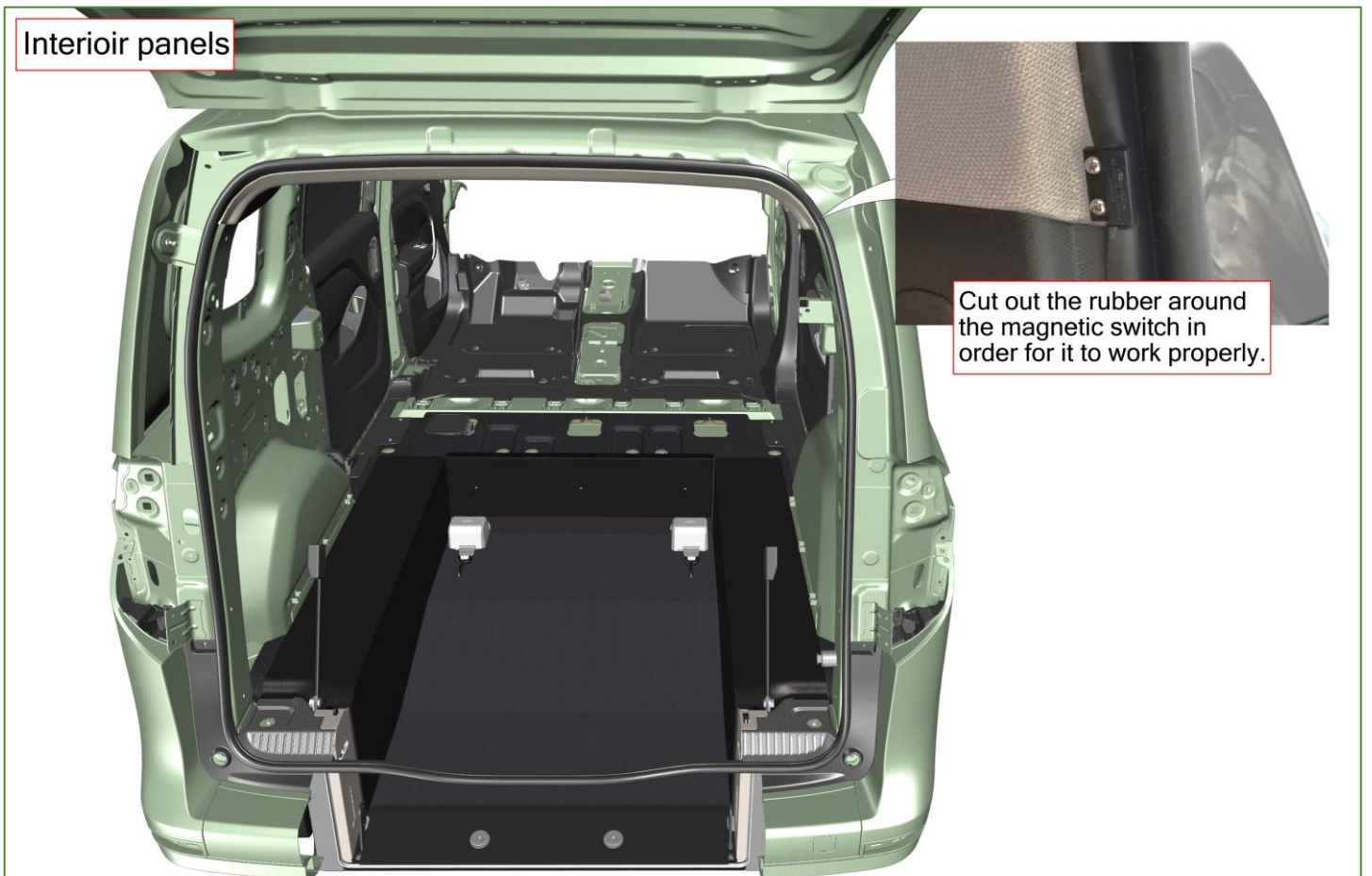

Cut out the rubber around the magnetic switch in order for it to work properly.

Place the OEM weather strip.

Interior panels

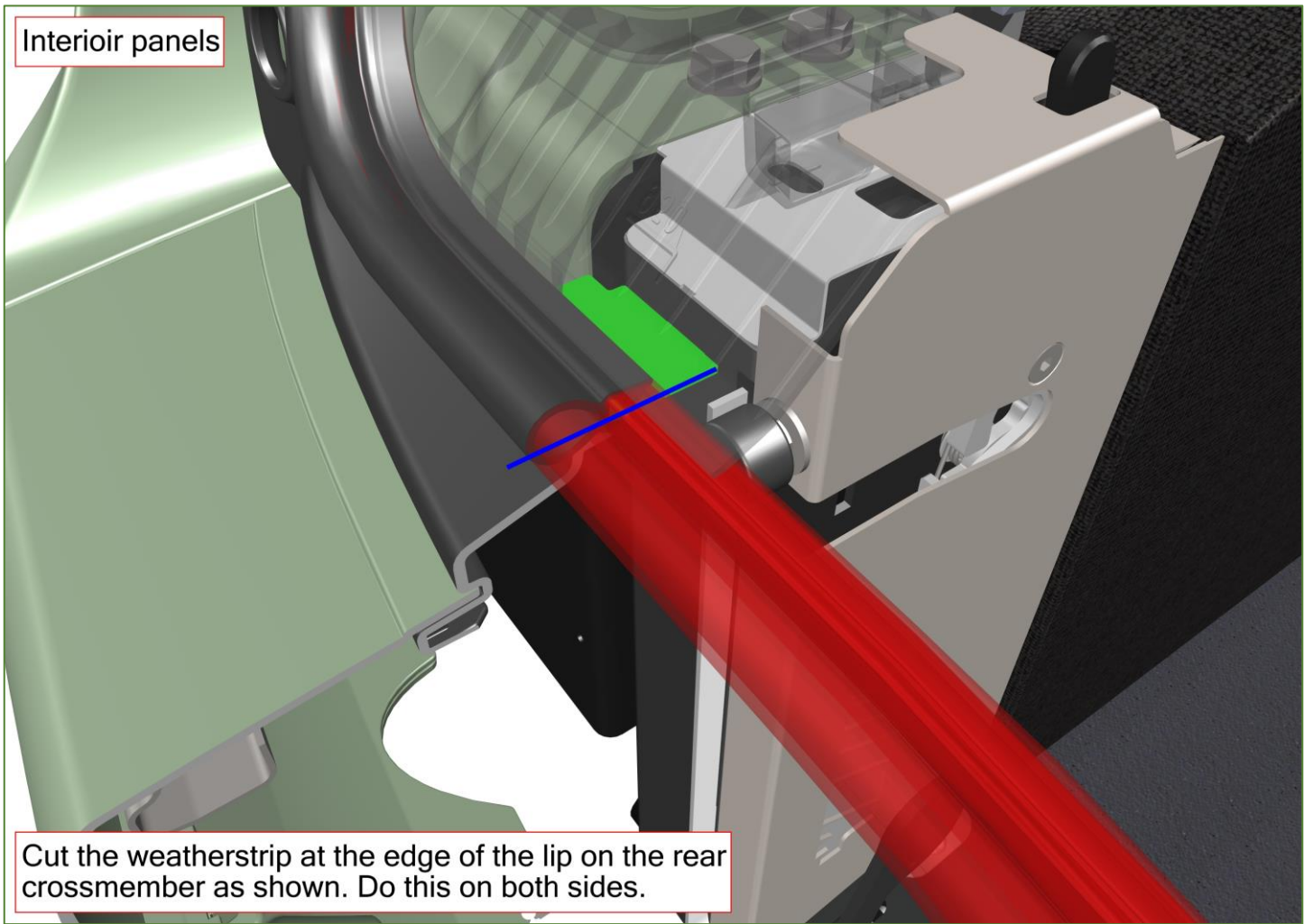

Cut the weatherstrip at the edge of the lip on the rear crossmember as shown. Do this on both sides.

Interior panels

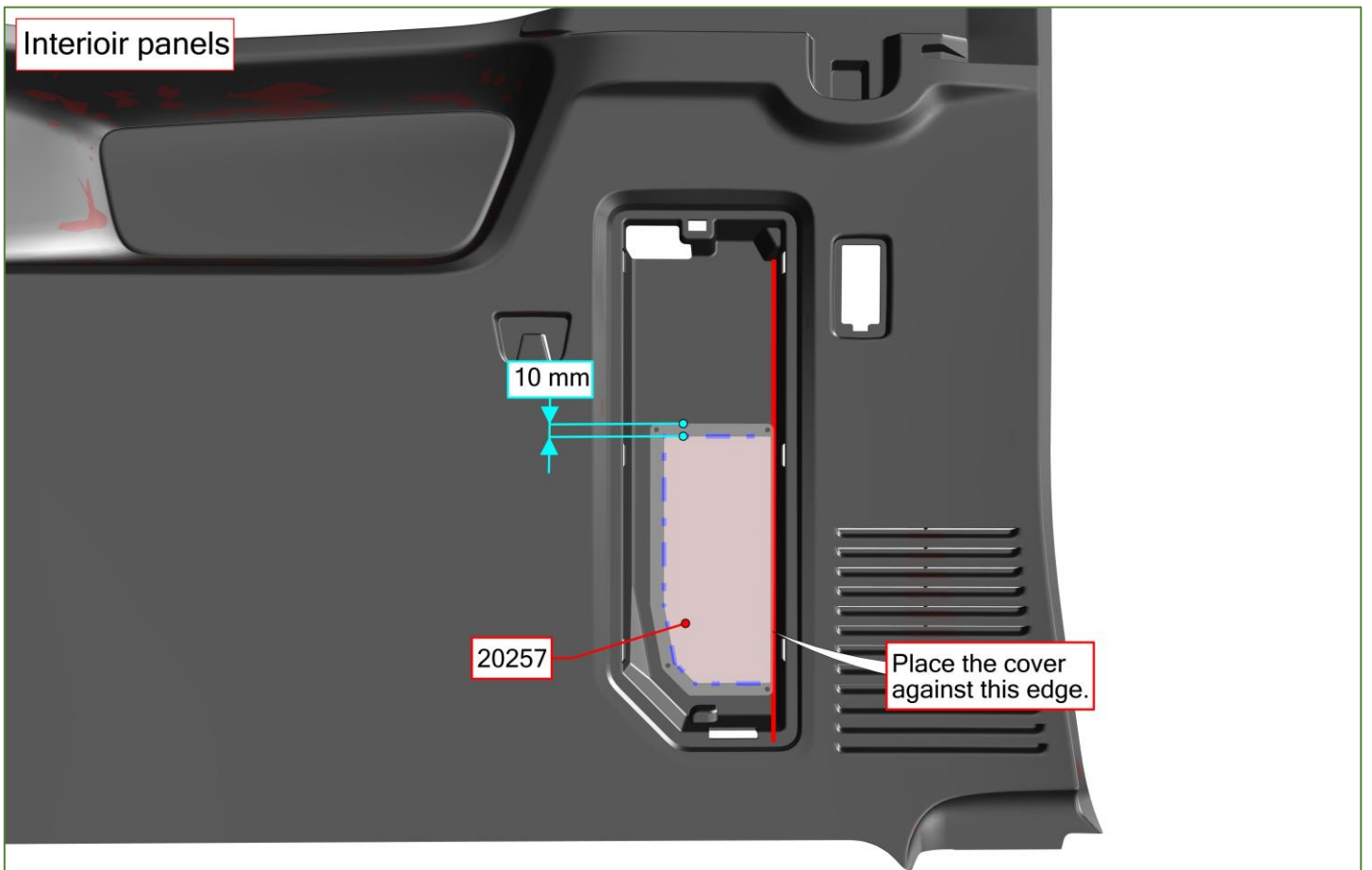

Place the cover as shown, mark the contour 10mm to the inside.



Interior panels

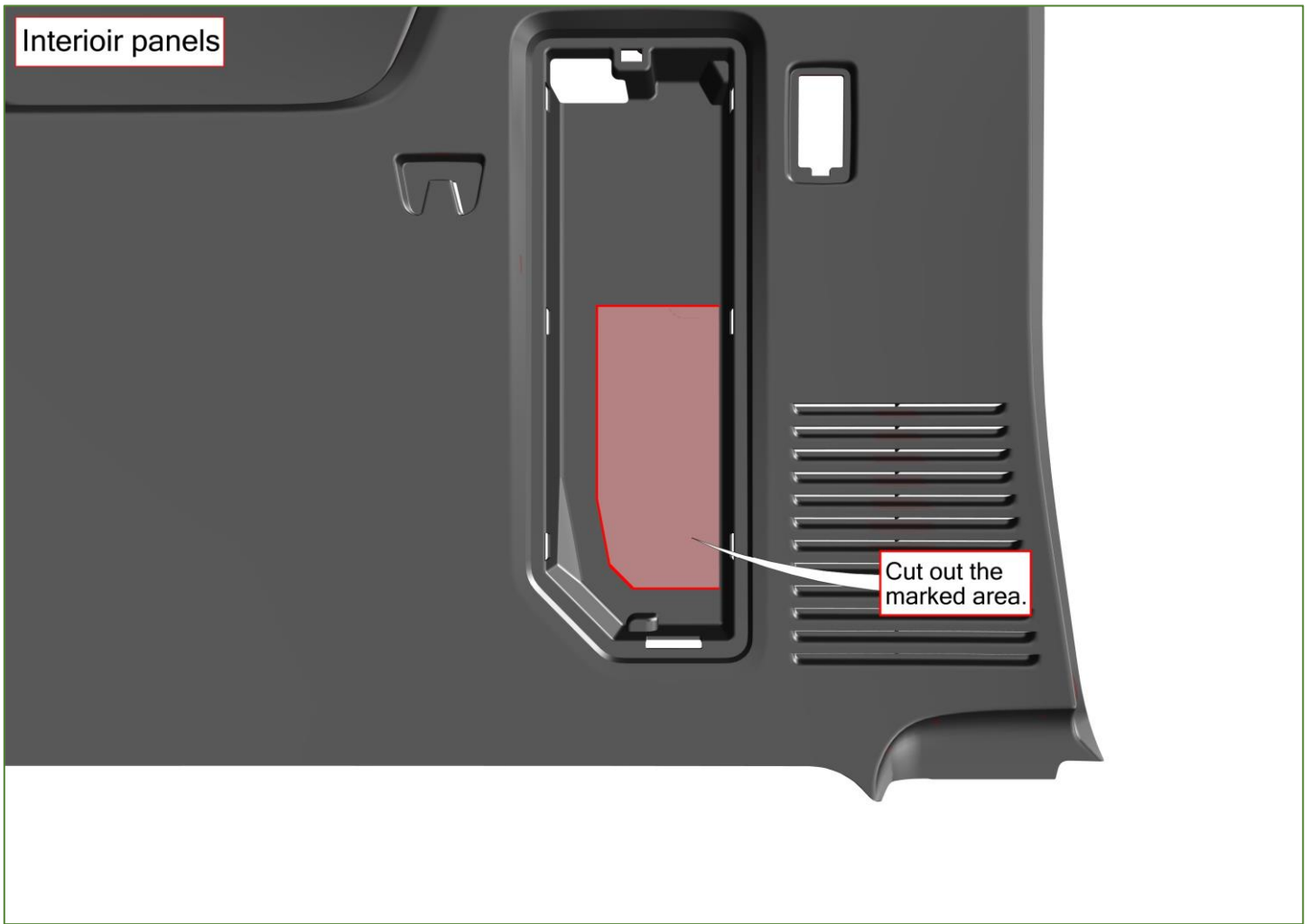

Interior panels

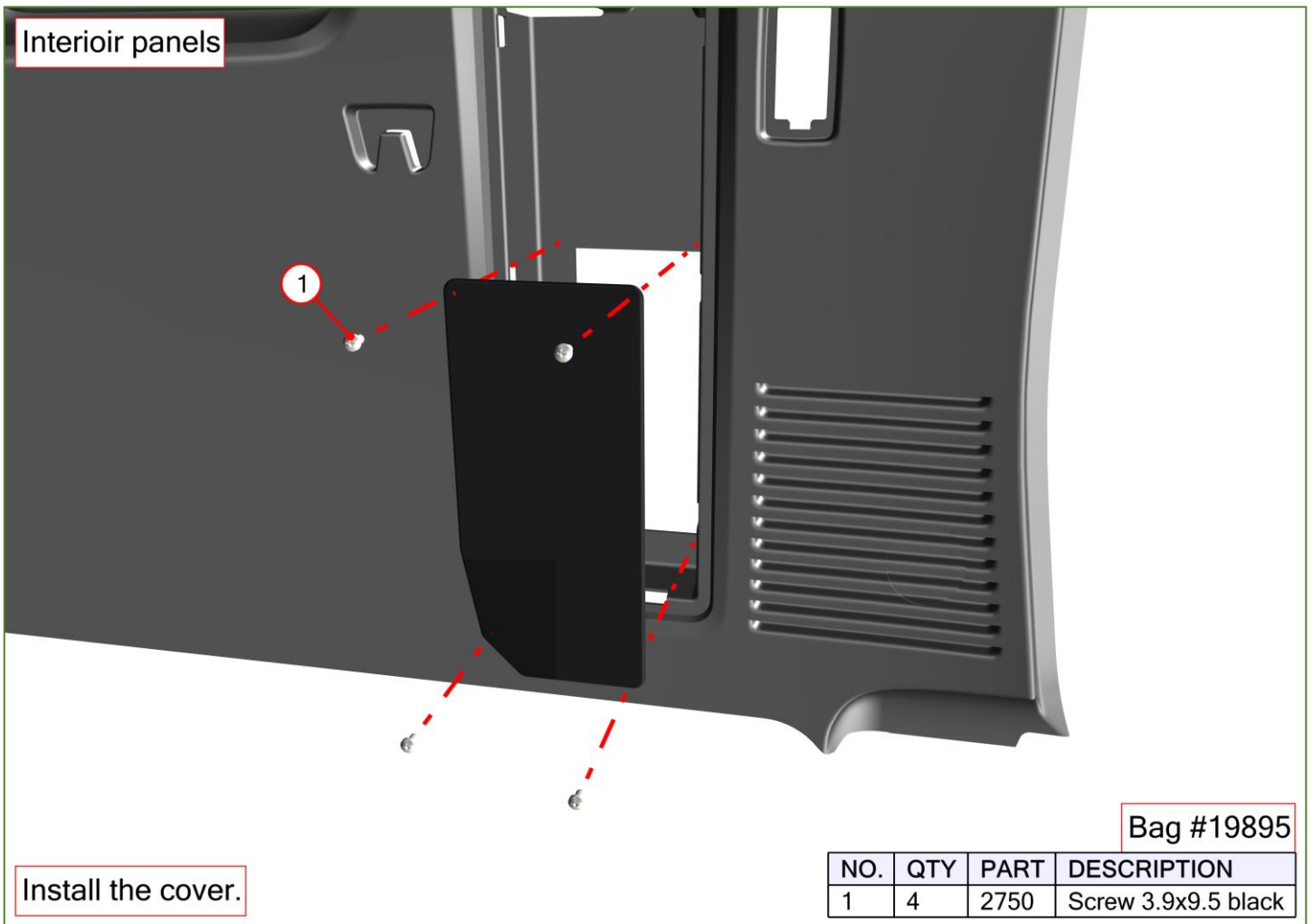

Install the cover.

Bag #19895

NO.	QTY	PART	DESCRIPTION
1	4	2750	Screw 3.9x9.5 black

Interior panels

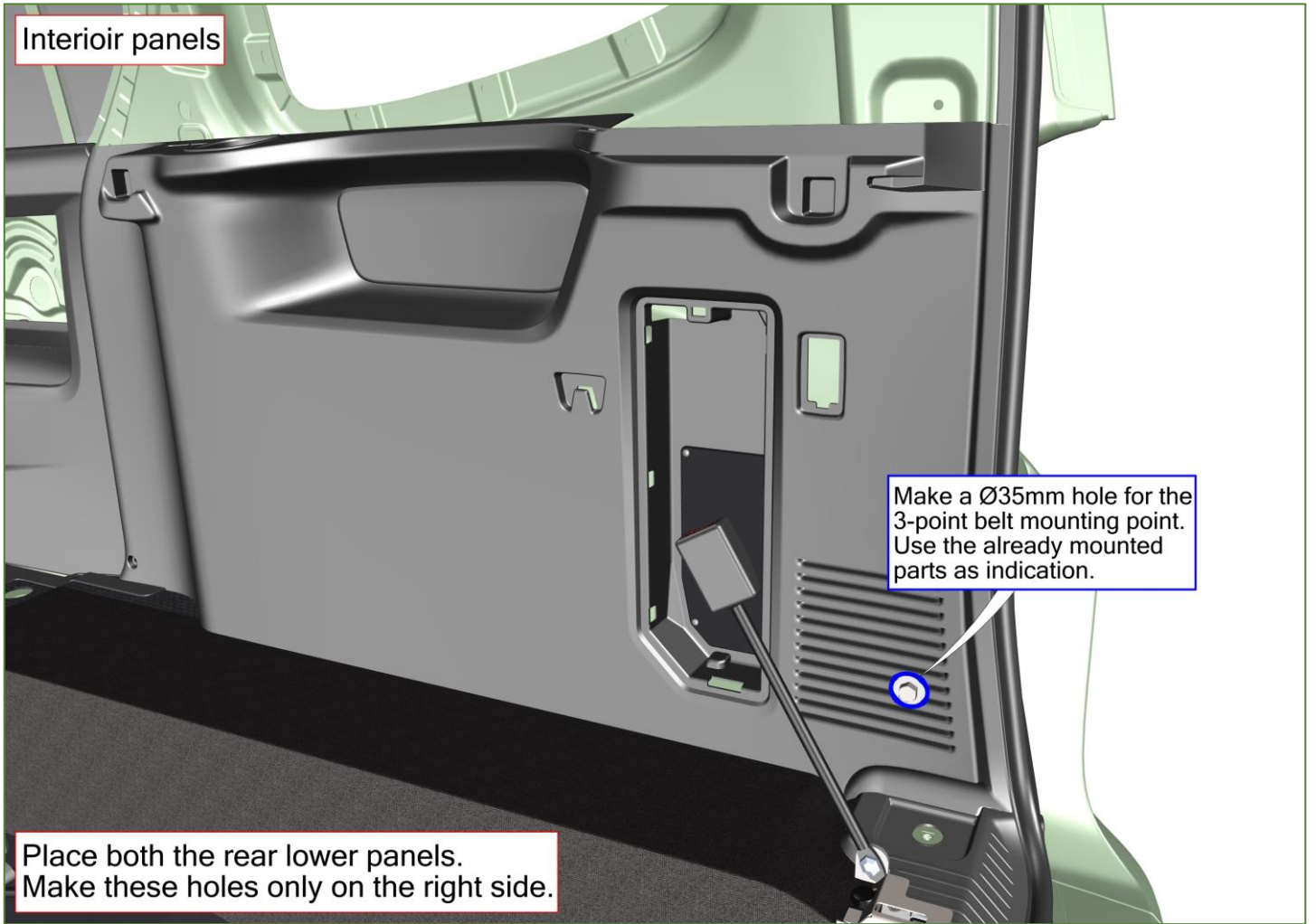

Interior panels

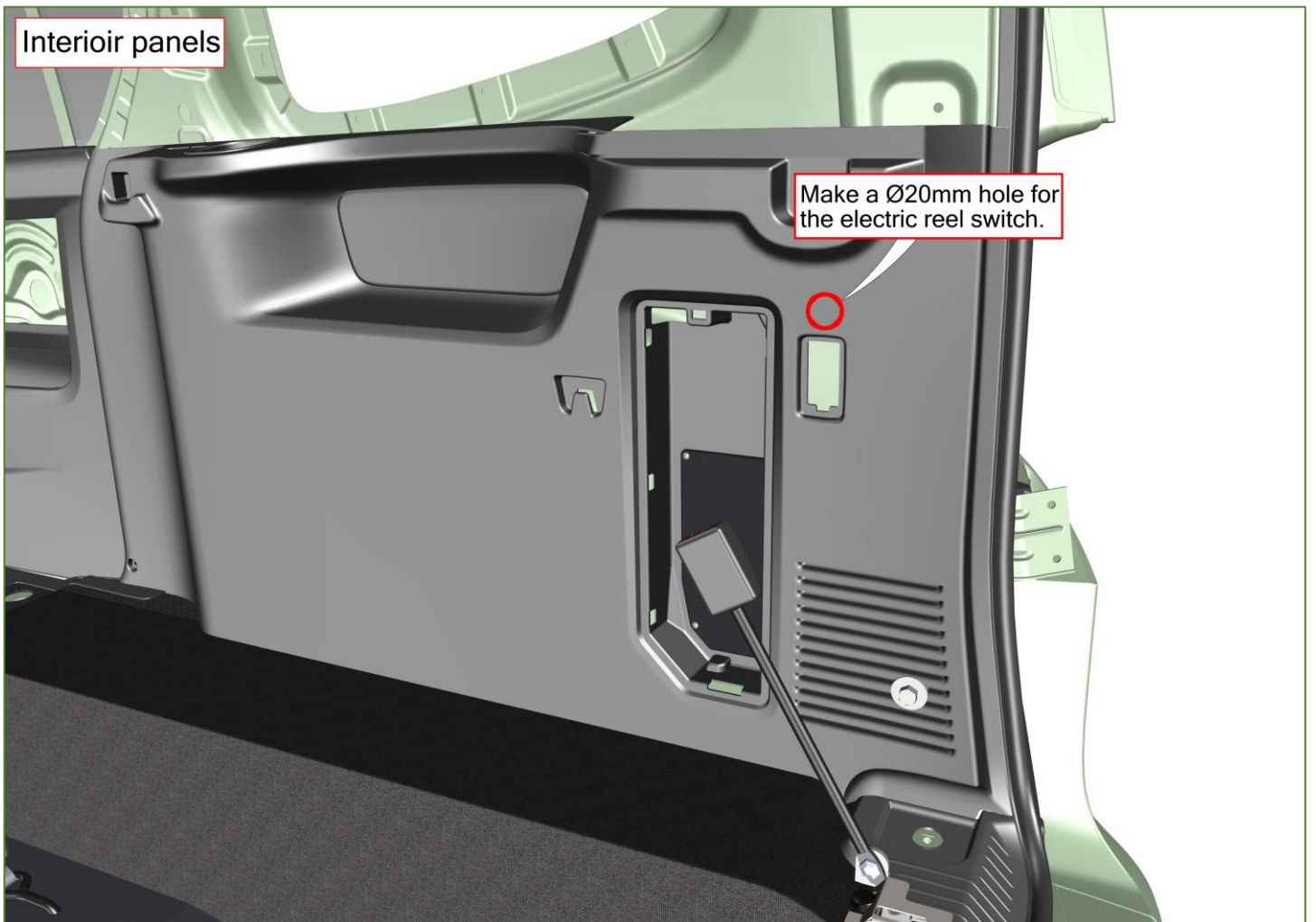

3-point belt install

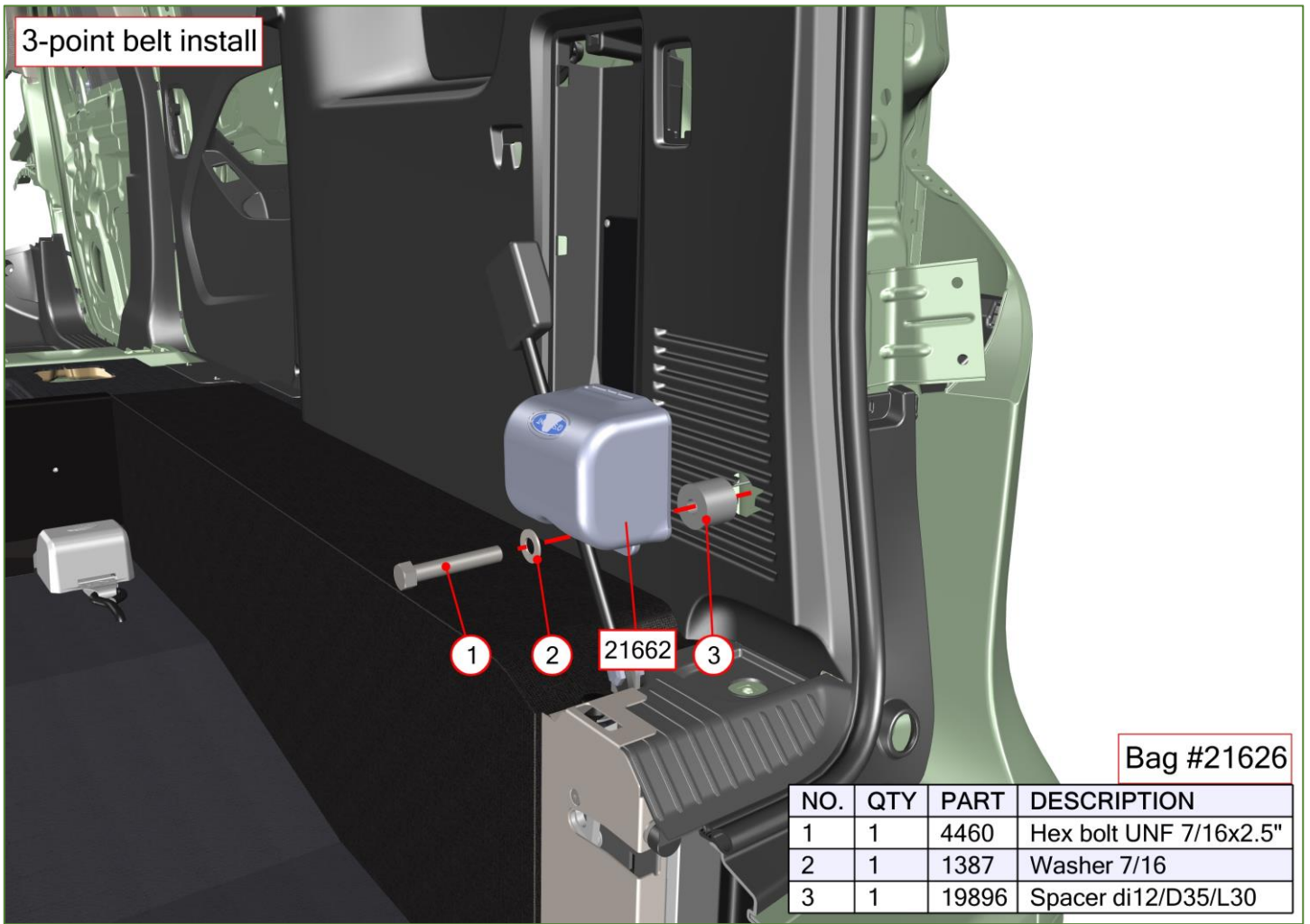

Bag #21626

3-point belt install

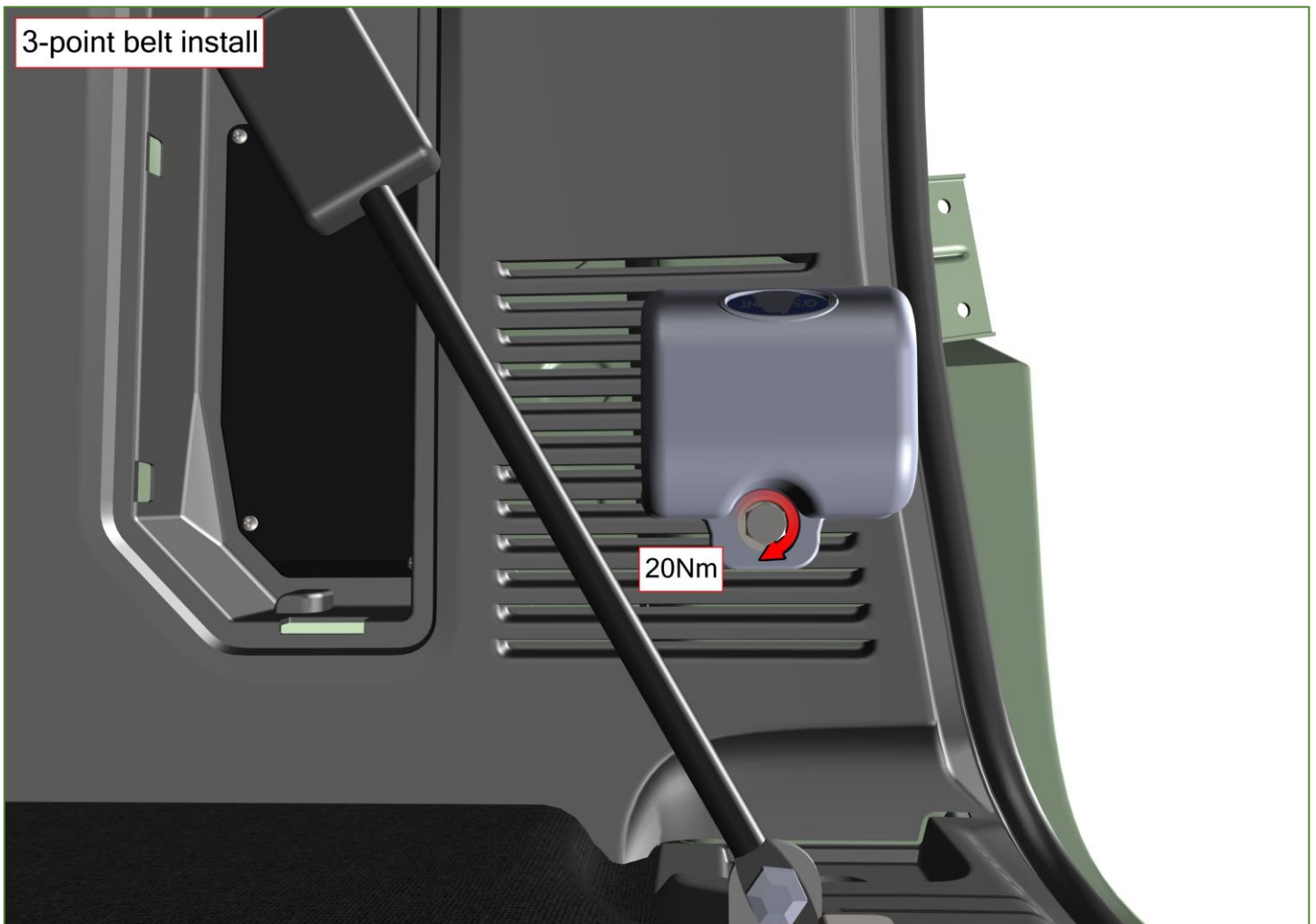

20Nm



### 3-point belt install

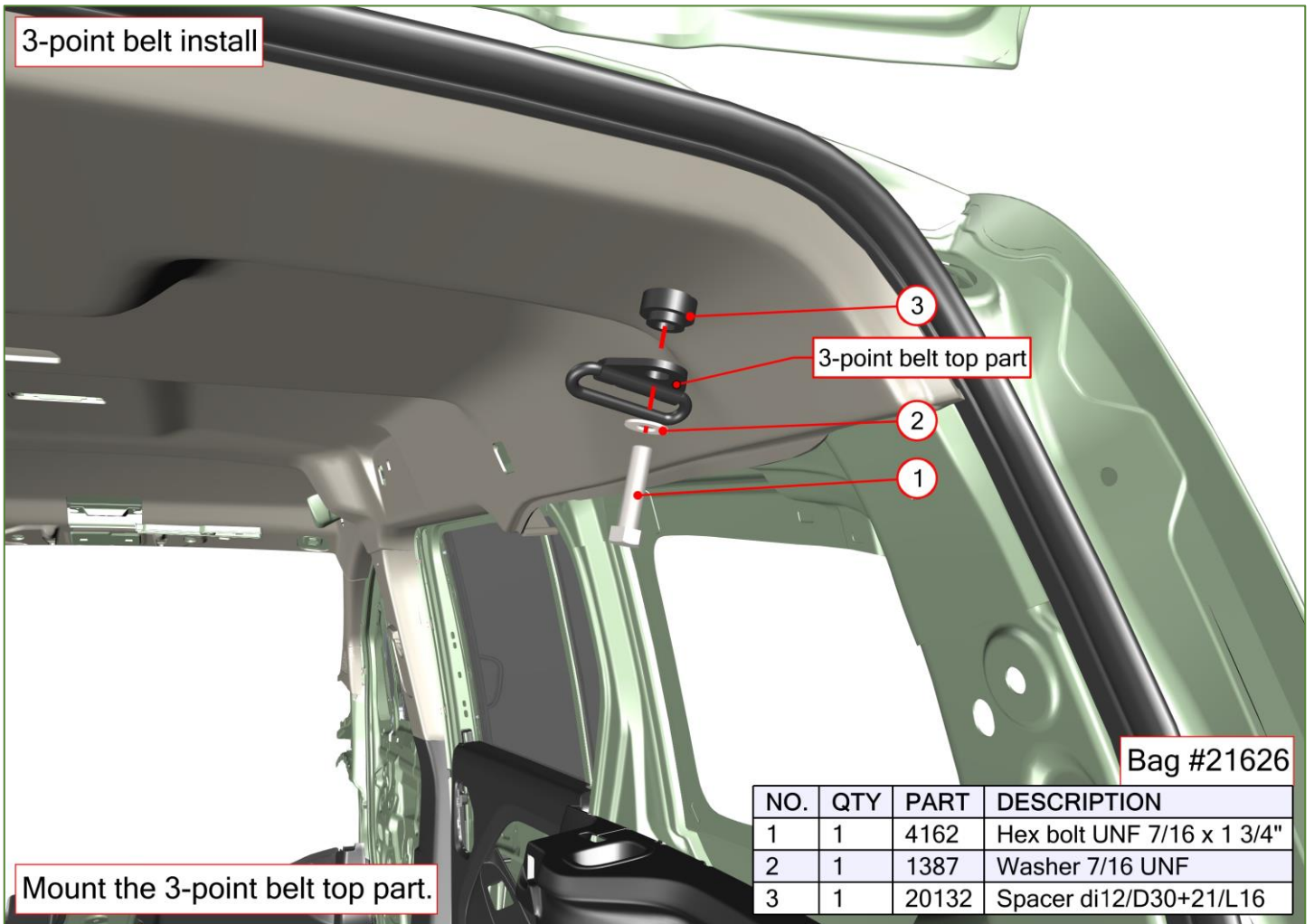

Mount the 3-point belt top part.

### 3-point belt install

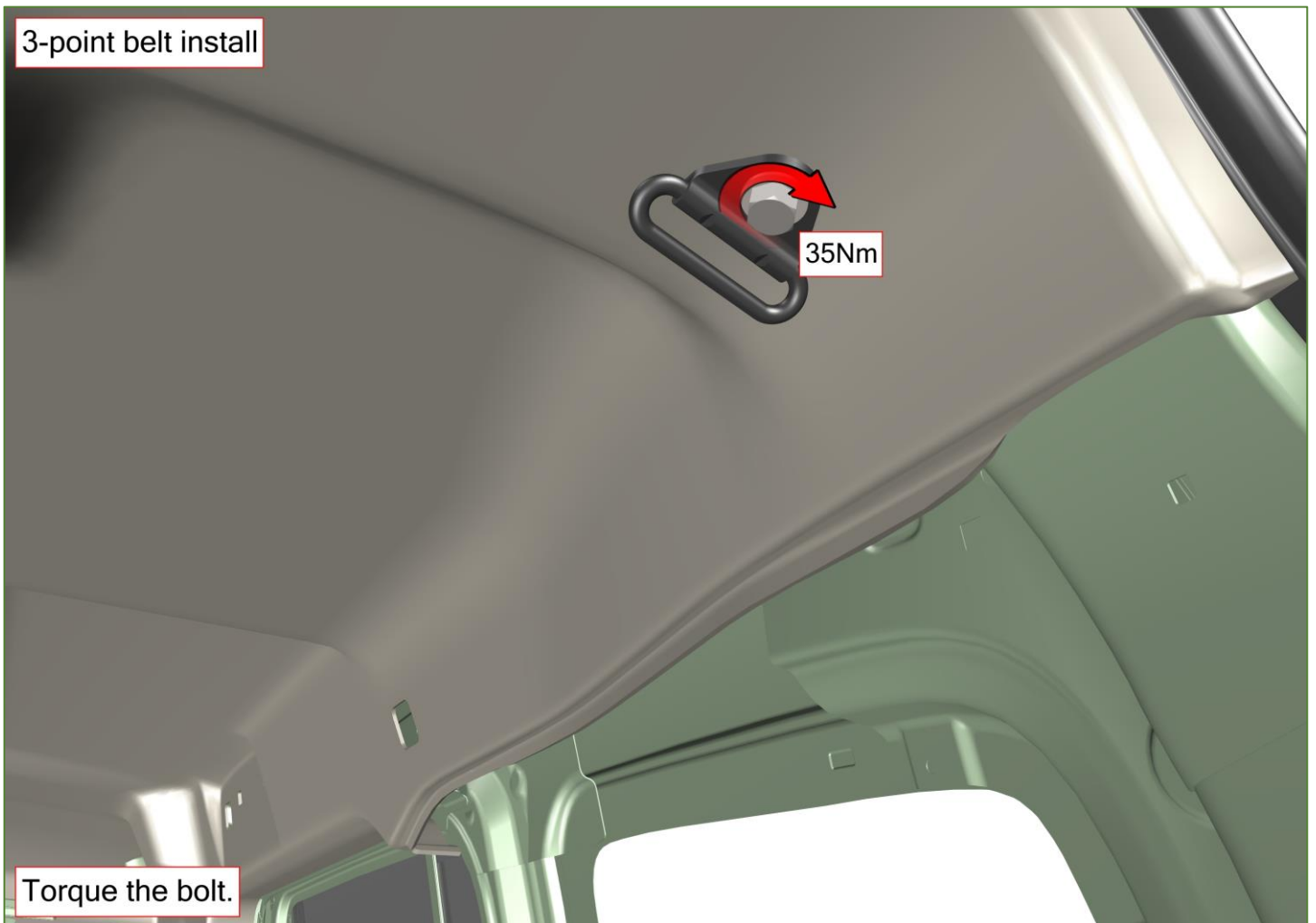

Torque the bolt.

Rear bumper support

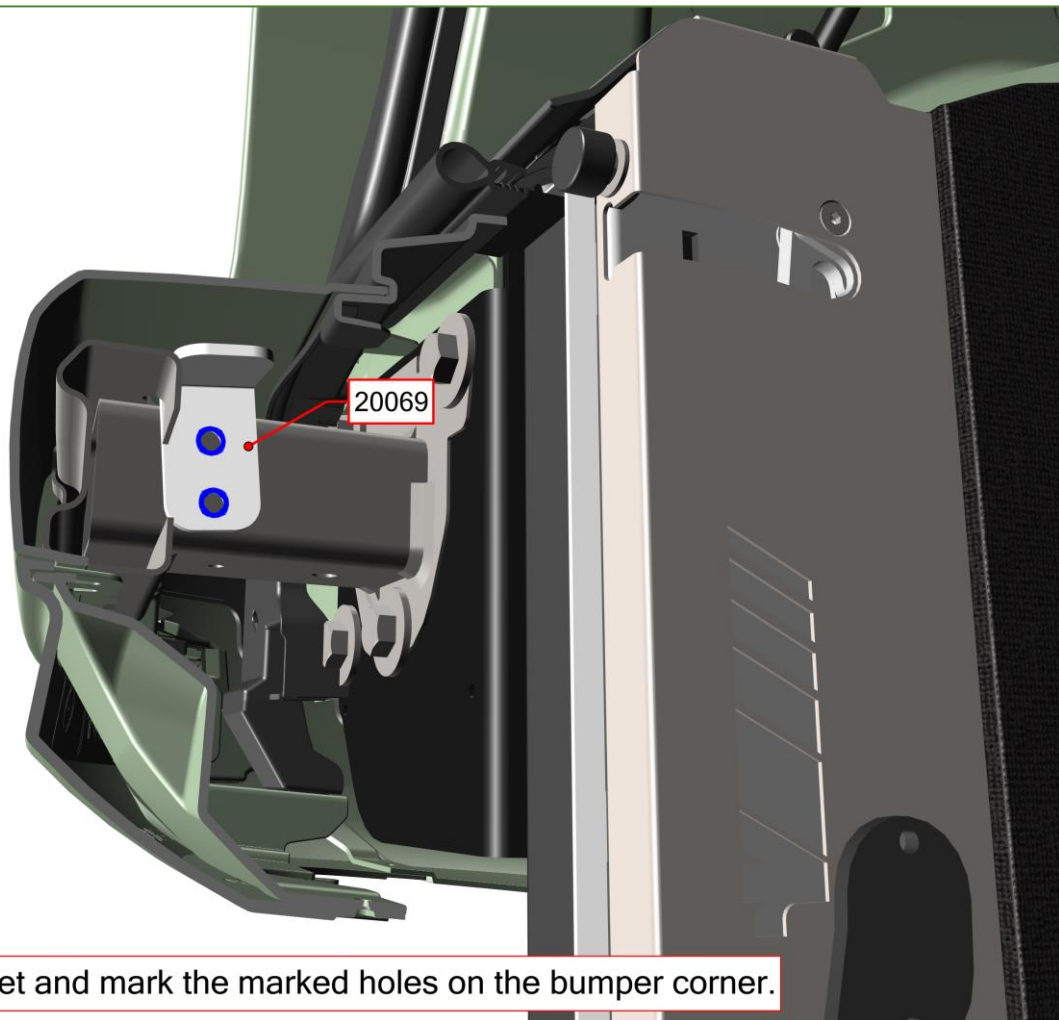

Place the bumper bracket and mark the marked holes on the bumper corner.

Rear bumper support

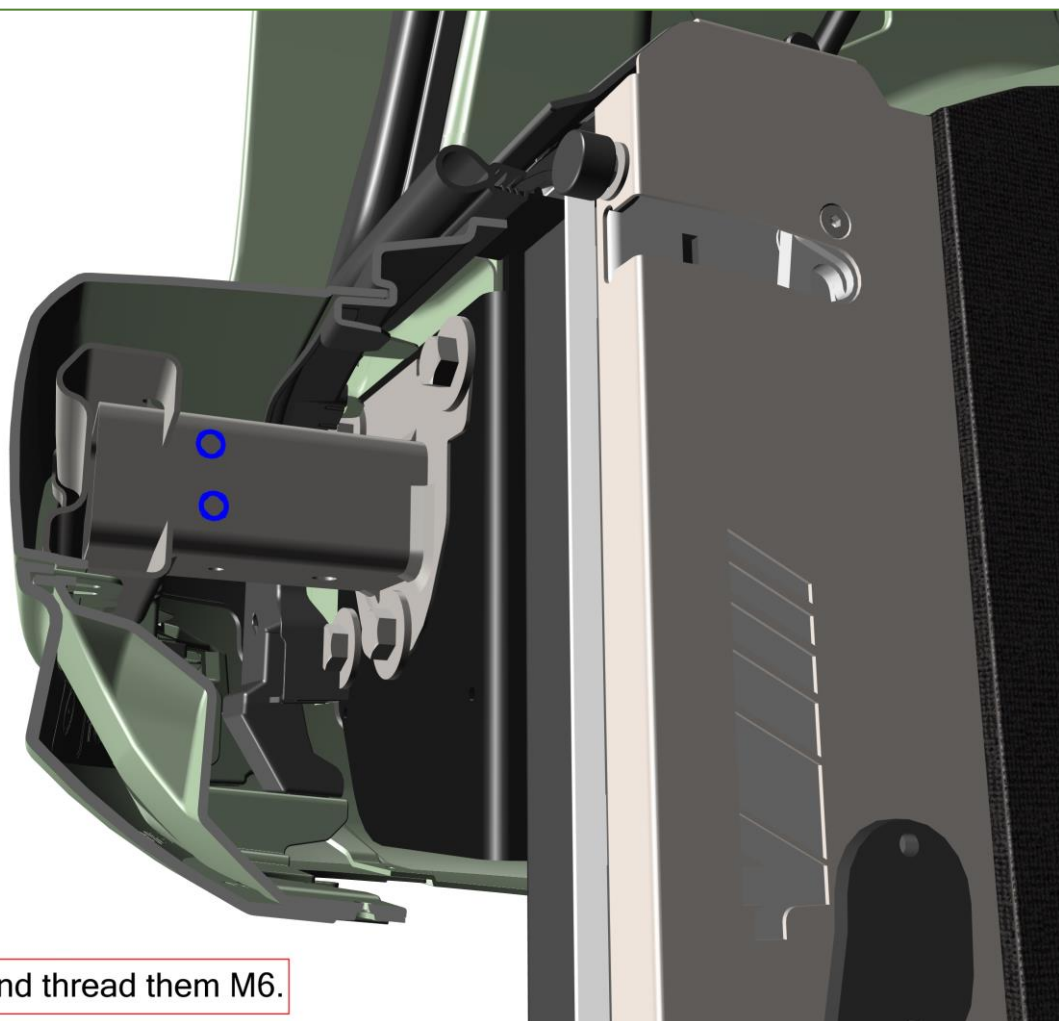

Drill the marked holes and thread them M6.

Rear bumper support

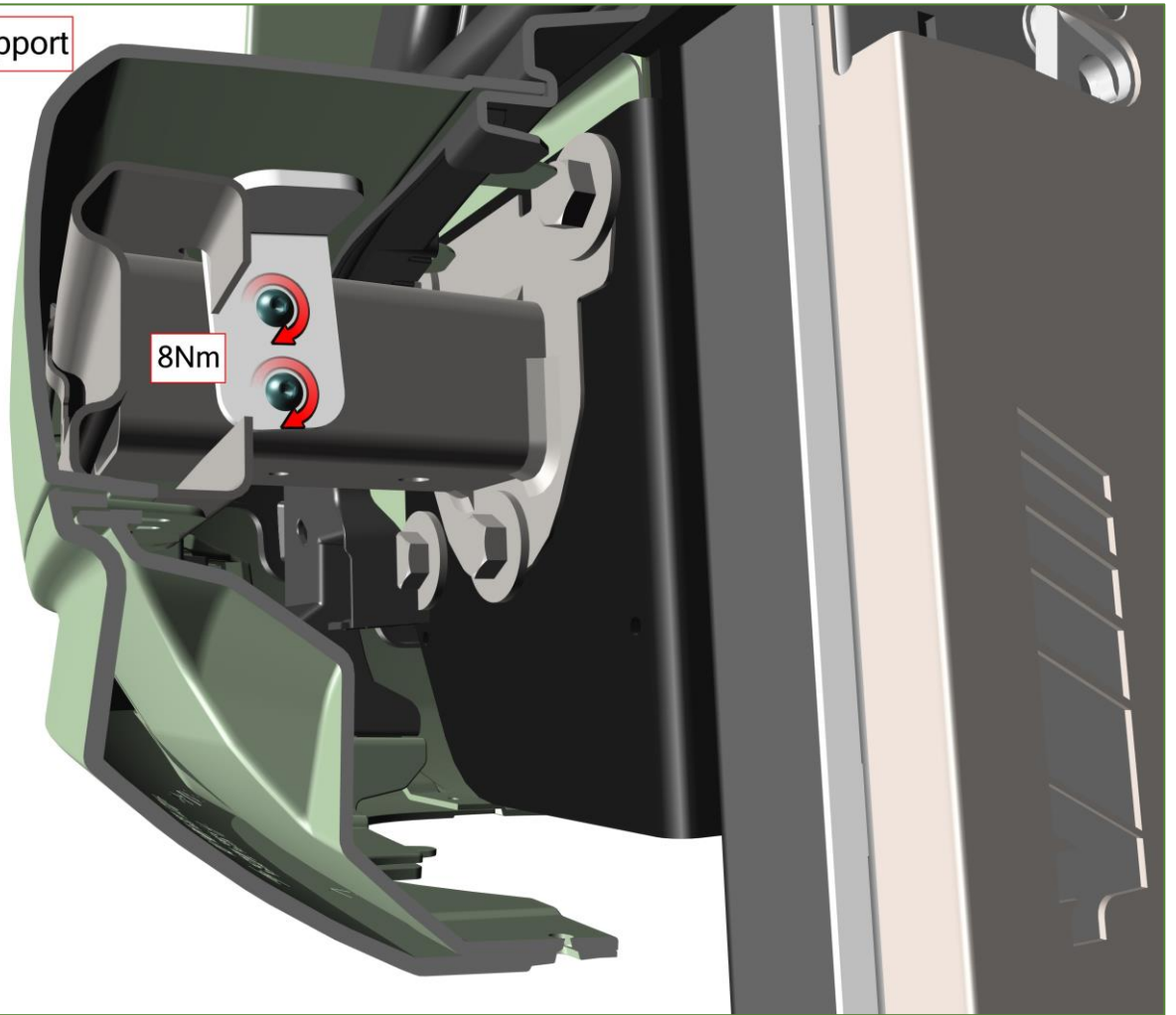

Rear bumper support

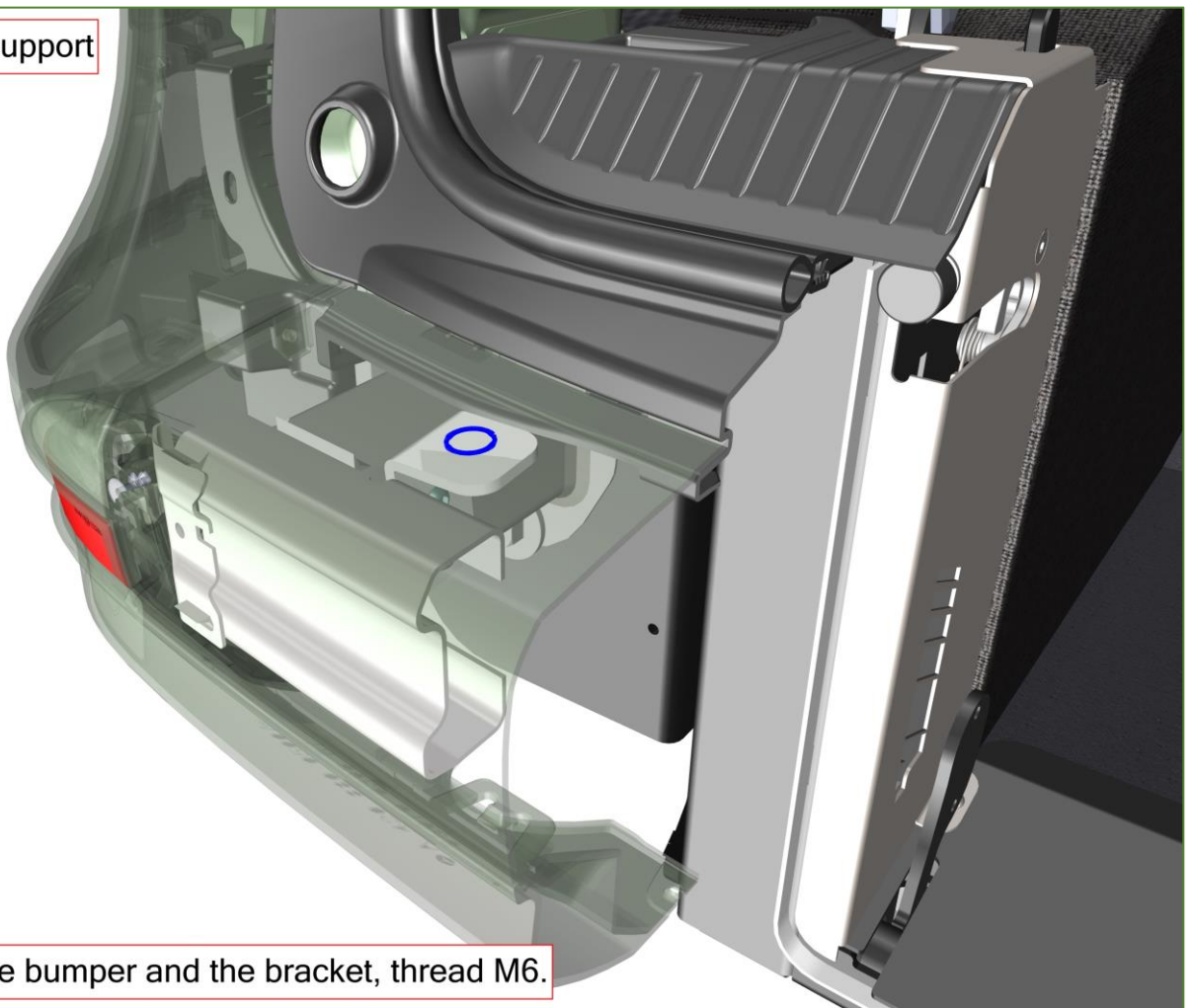

Drill through the bumper and the bracket, thread M6.



### Rear bumper support

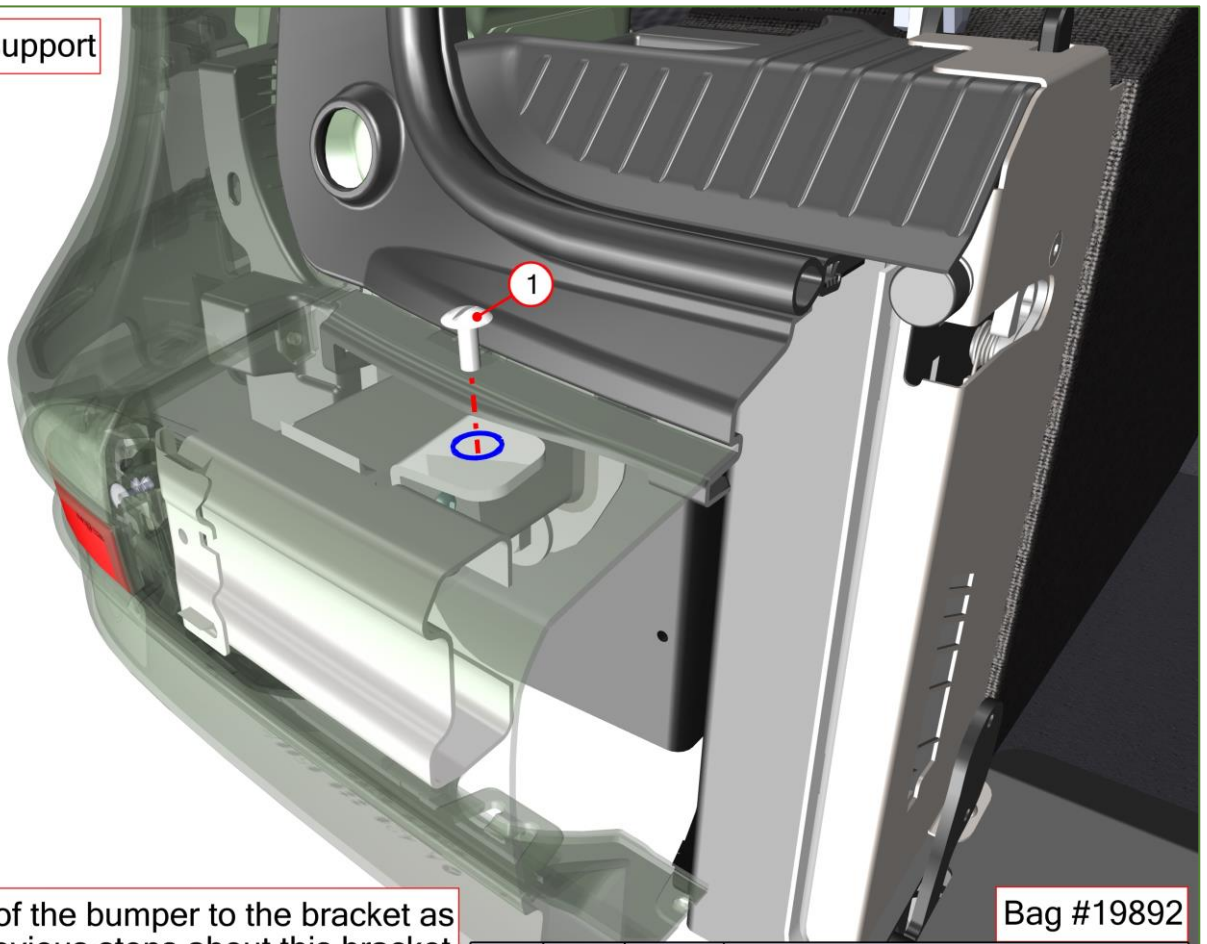

Mount the top of the bumper to the bracket as shown. The previous steps about this bracket can be exactly replicated on the other side.

Bag #19892

NO.	QTY	PART	DESCRIPTION
1	1	10387	Nylon button head screw M6x16 PA6

### Ramp

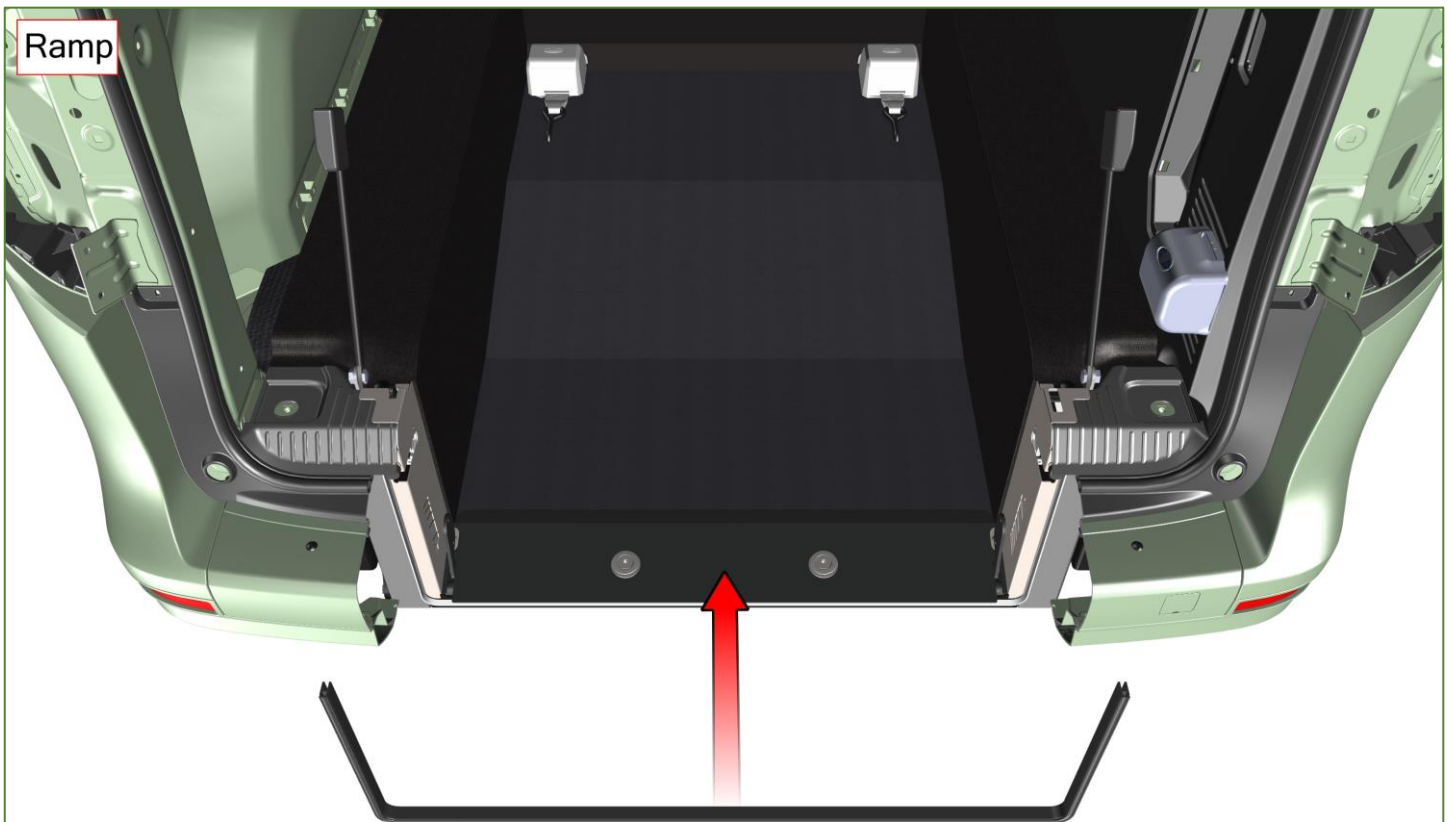

Install the rear crossmember/ramp rubber seal.

Ramp

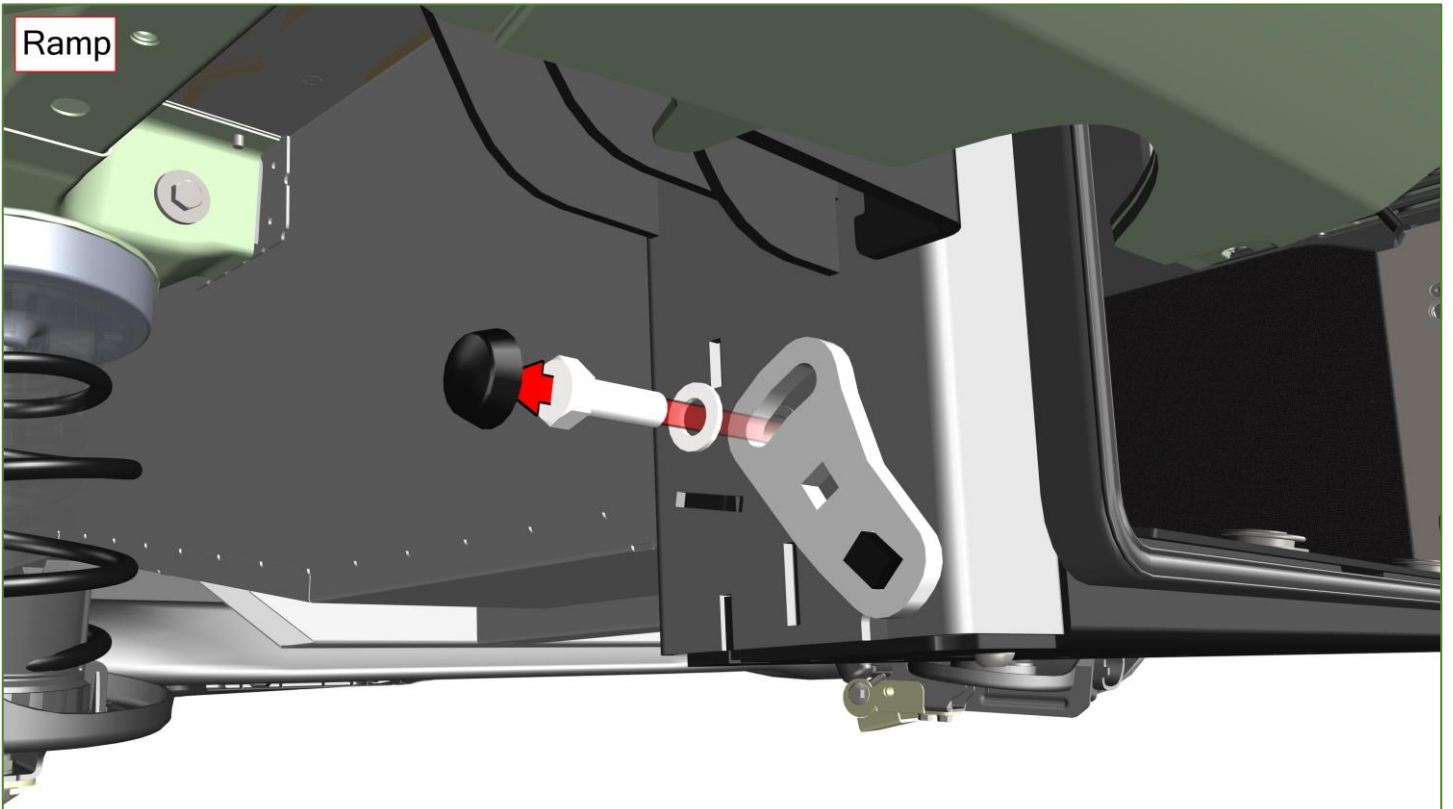

Before installing the ramp, remove these parts.

Ramp

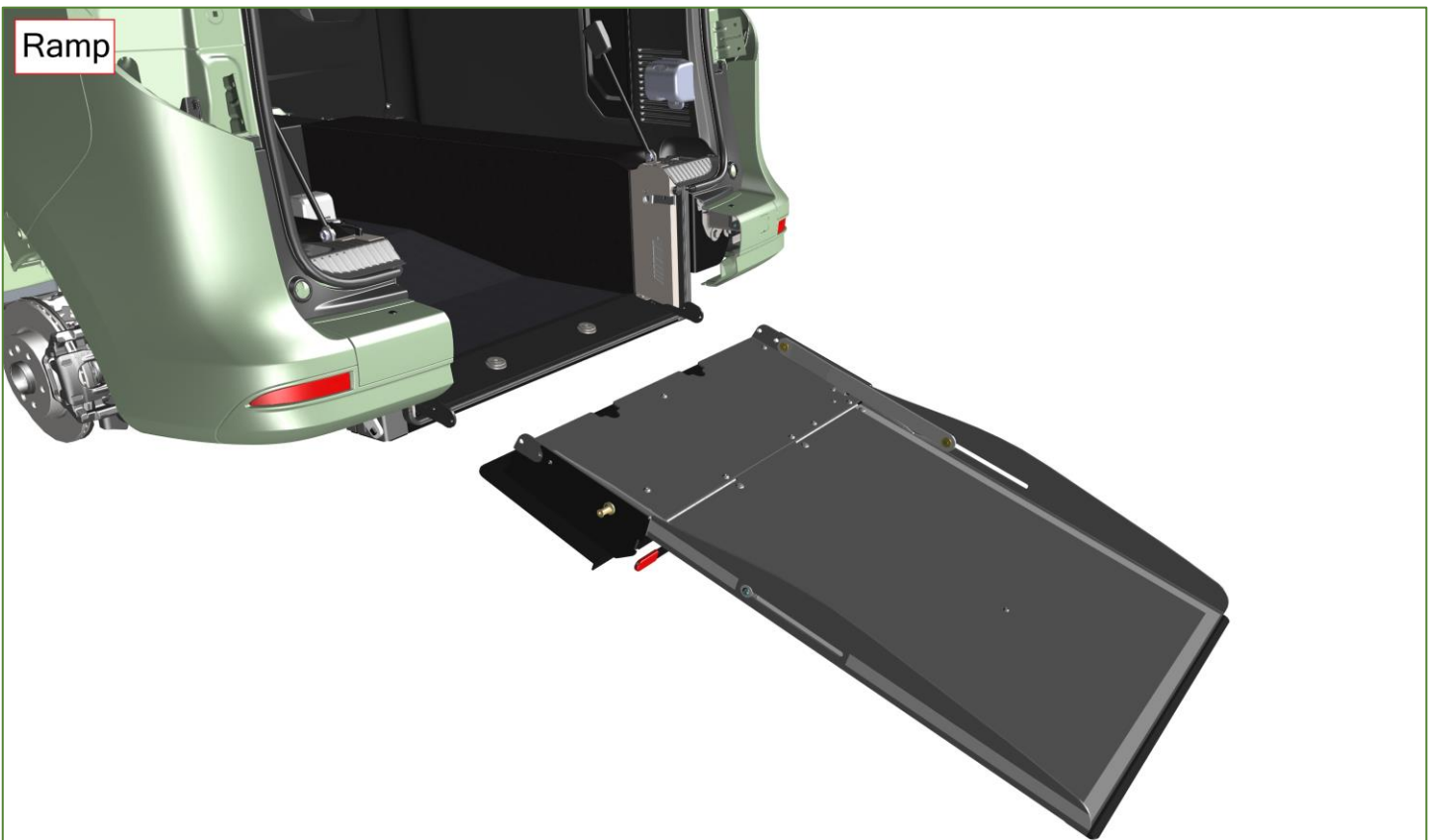

Install the clearview ramp or the taxi ramp.  
Both are installed in the same way.

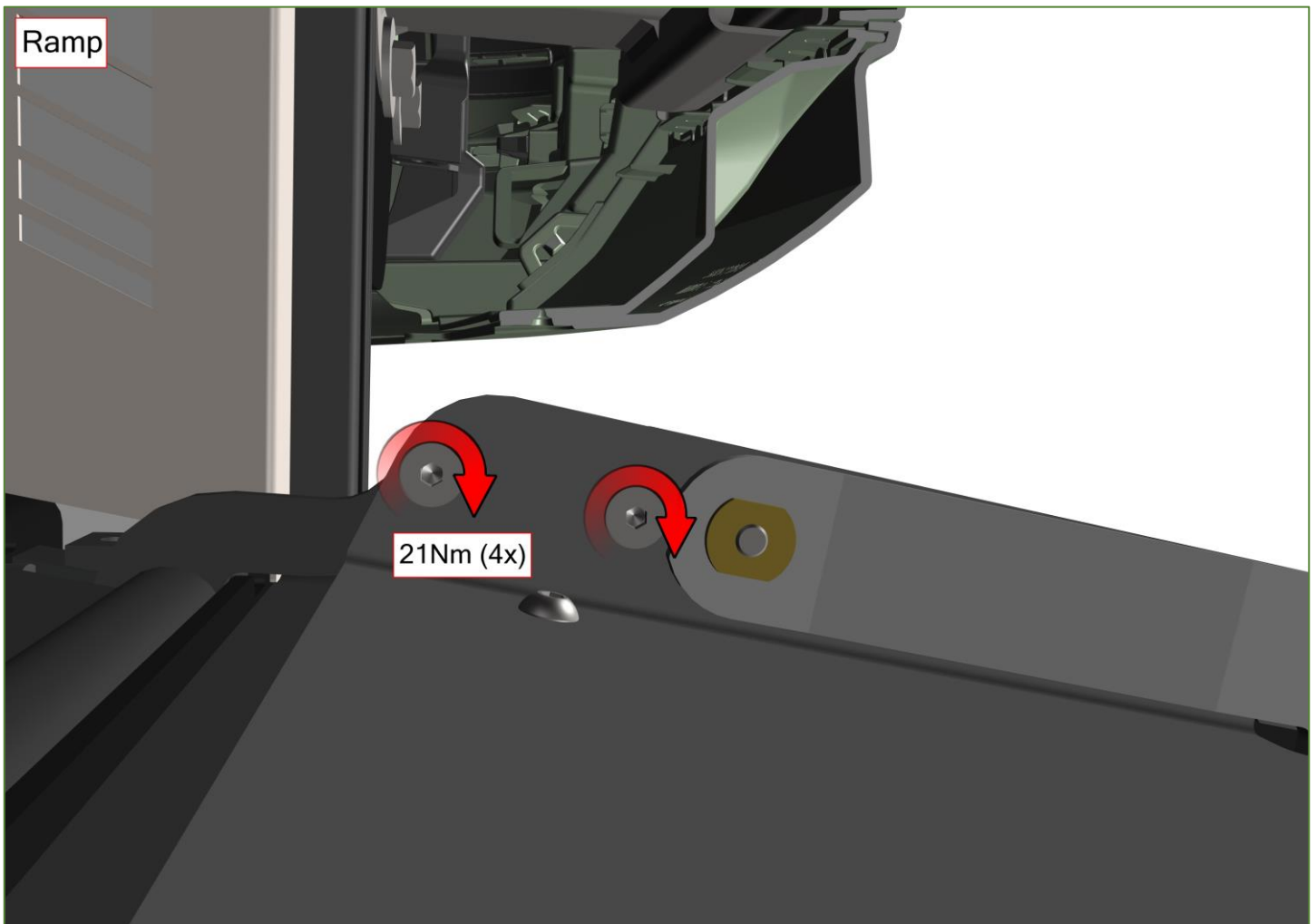
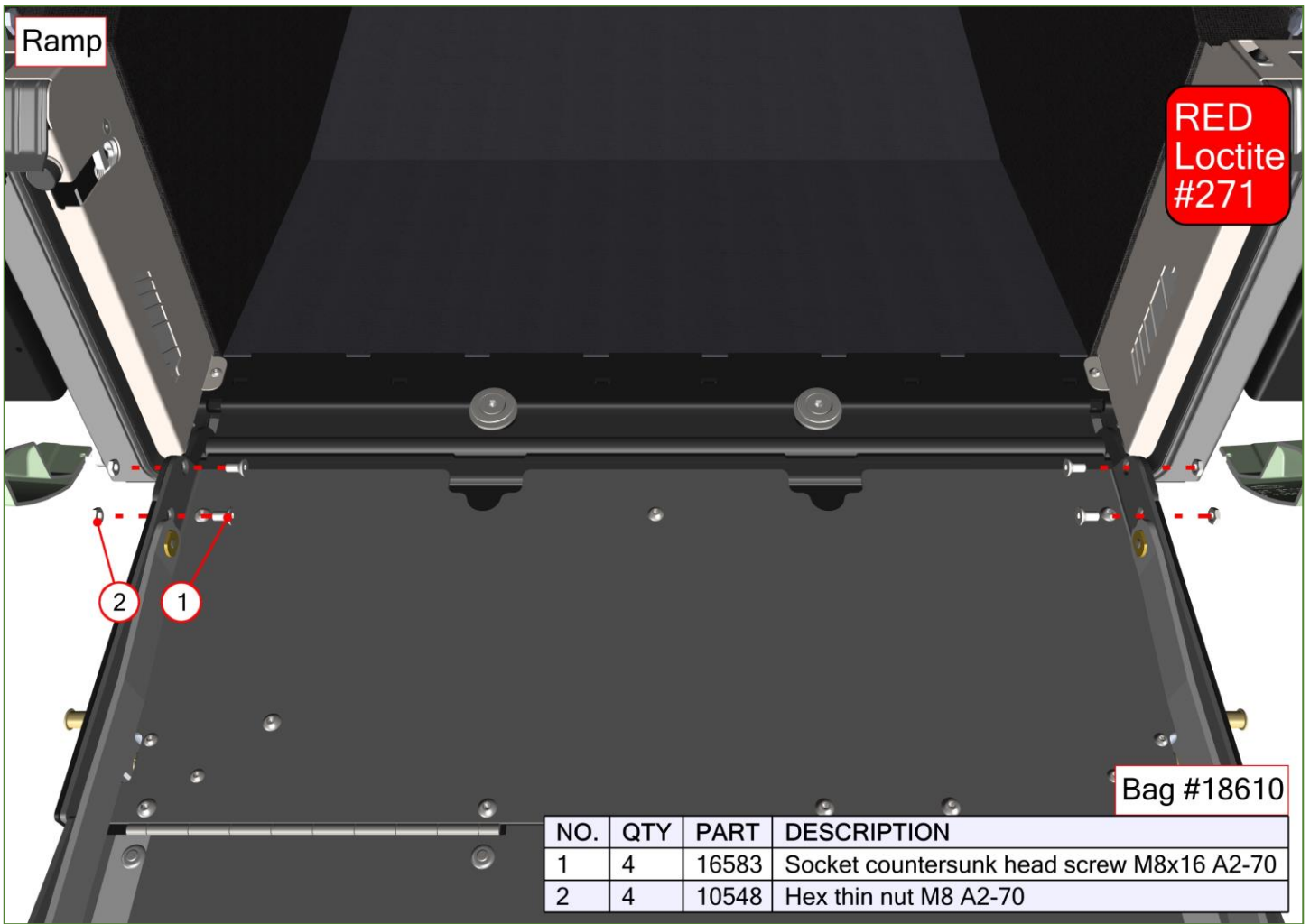



Ramp

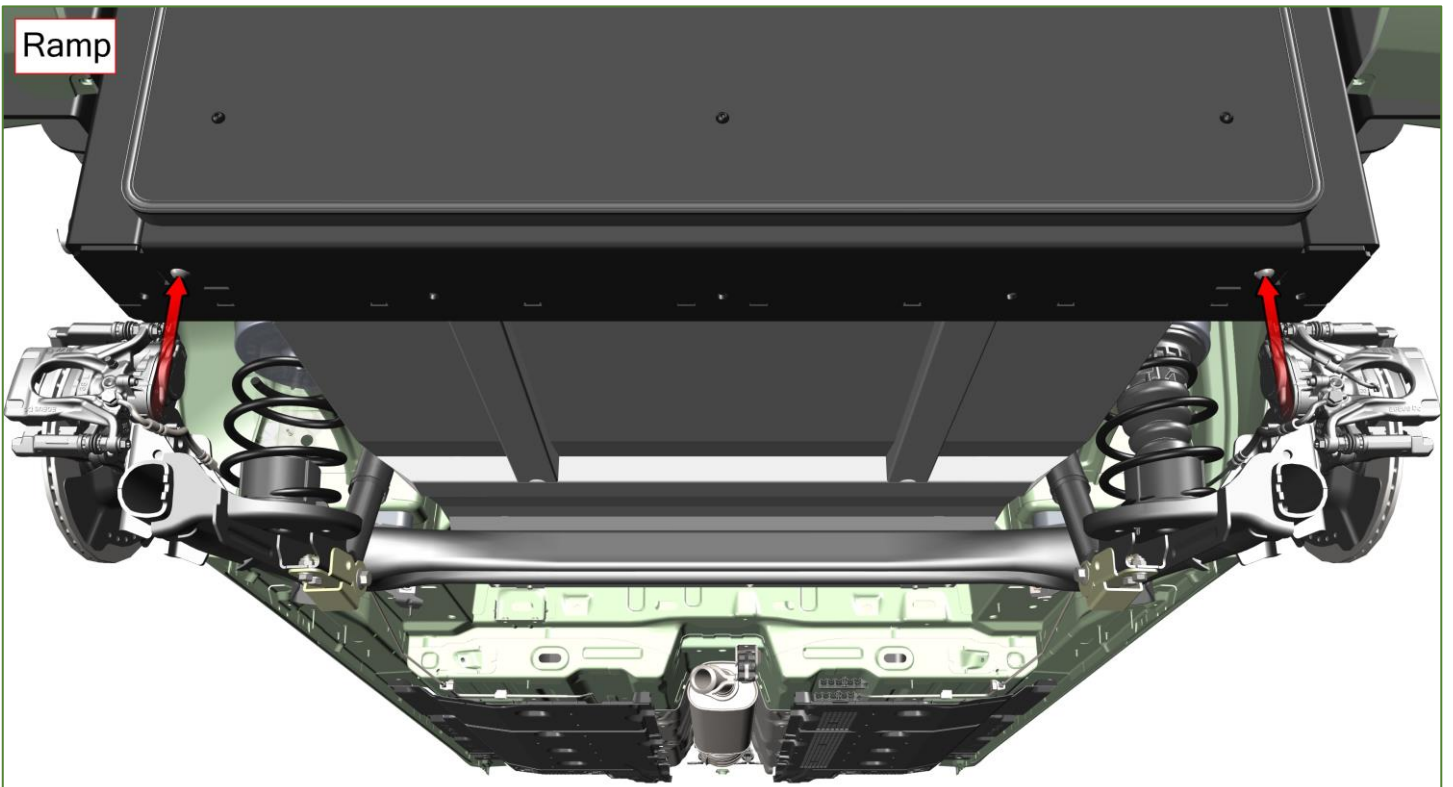

If the ramp is not centered correctly adjust it by loosening these 2 screws, 2 full turns maximum!

Ramp

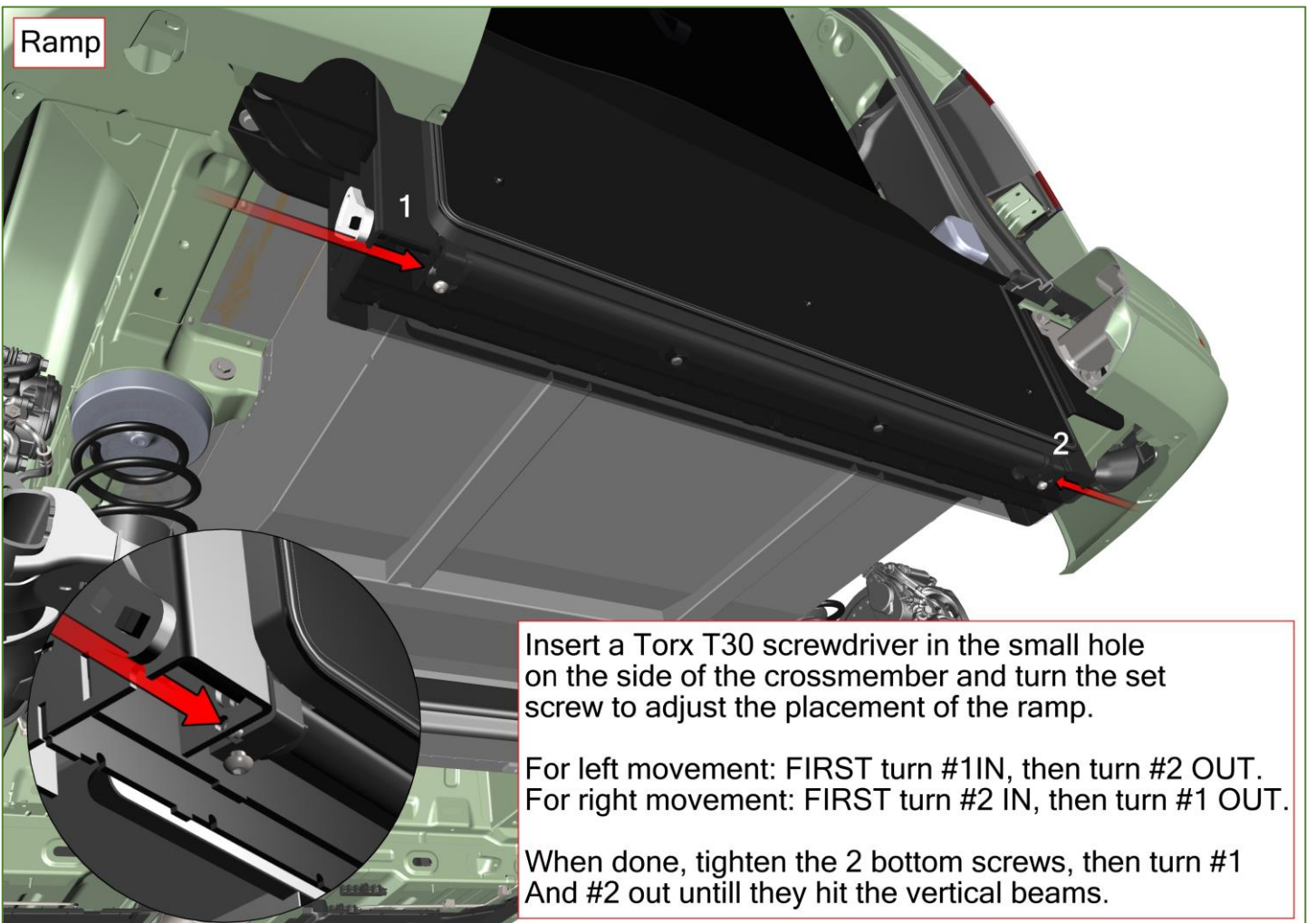

Insert a Torx T30 screwdriver in the small hole on the side of the crossmember and turn the set screw to adjust the placement of the ramp.

For left movement: FIRST turn #1 IN, then turn #2 OUT.  
For right movement: FIRST turn #2 IN, then turn #1 OUT.

When done, tighten the 2 bottom screws, then turn #1 And #2 out until they hit the vertical beams.

Ramp



With the ramp in upright position, turn the torsion spring as far counter clockwise as possible. Like shown.

Ramp

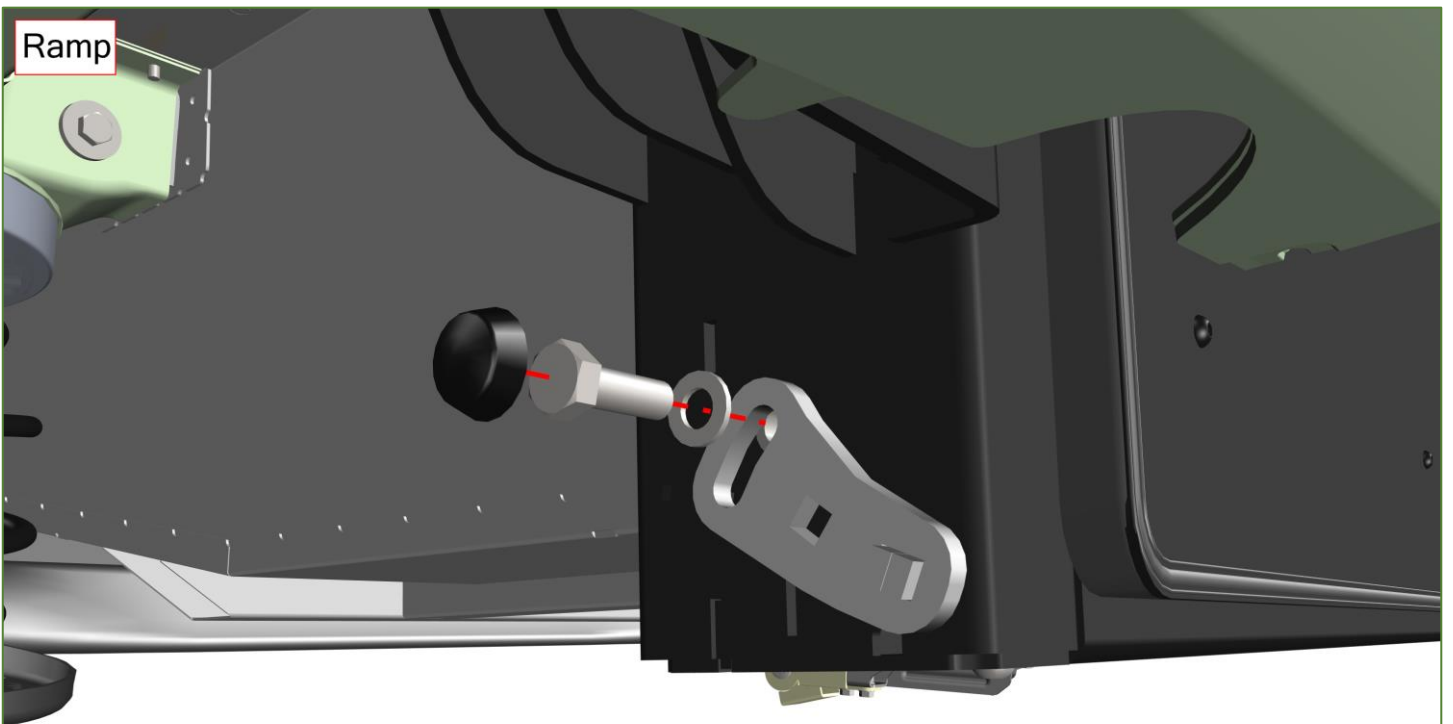

Reinstall the mounting parts of the torsion spring as shown.

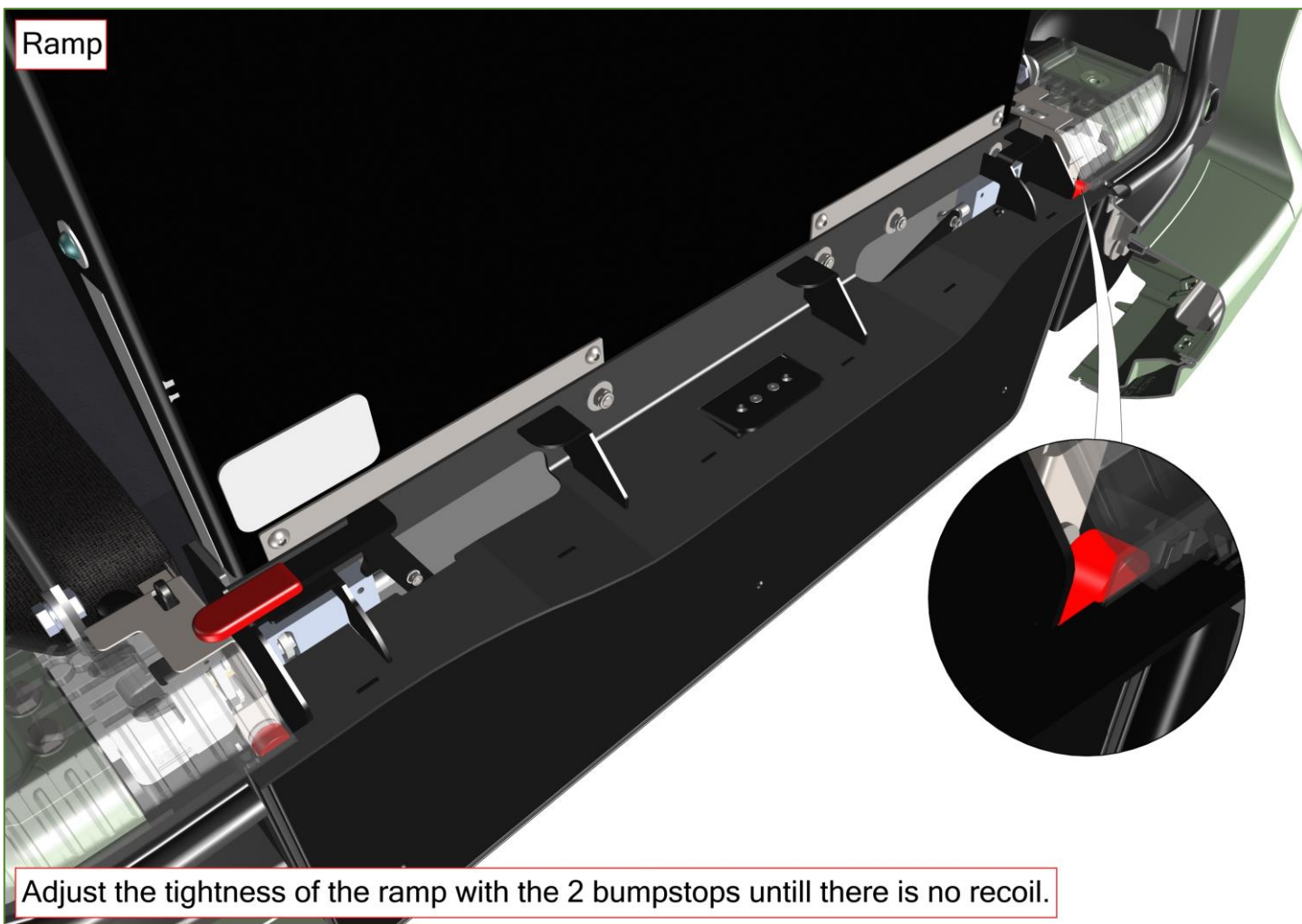
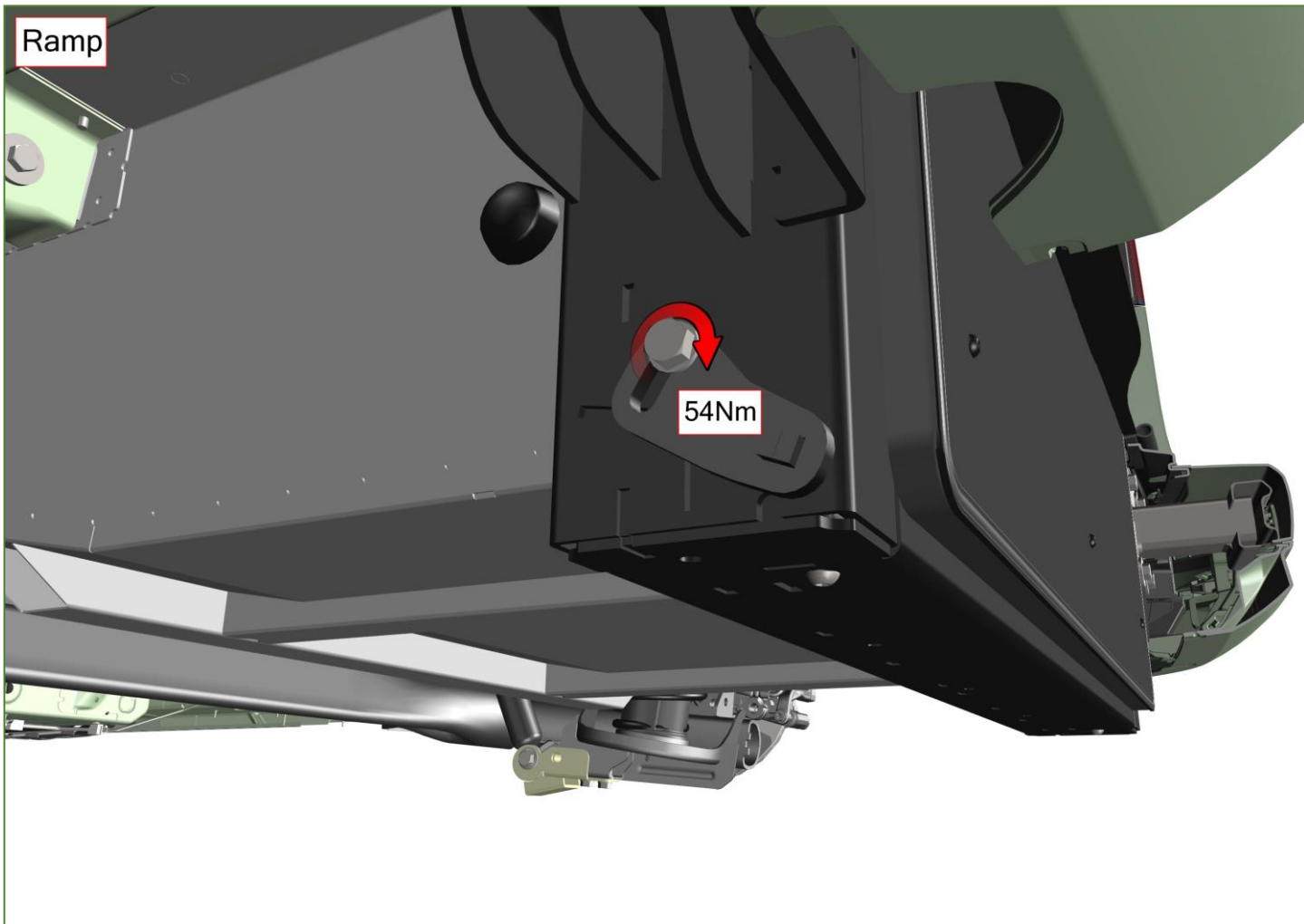



Ramp

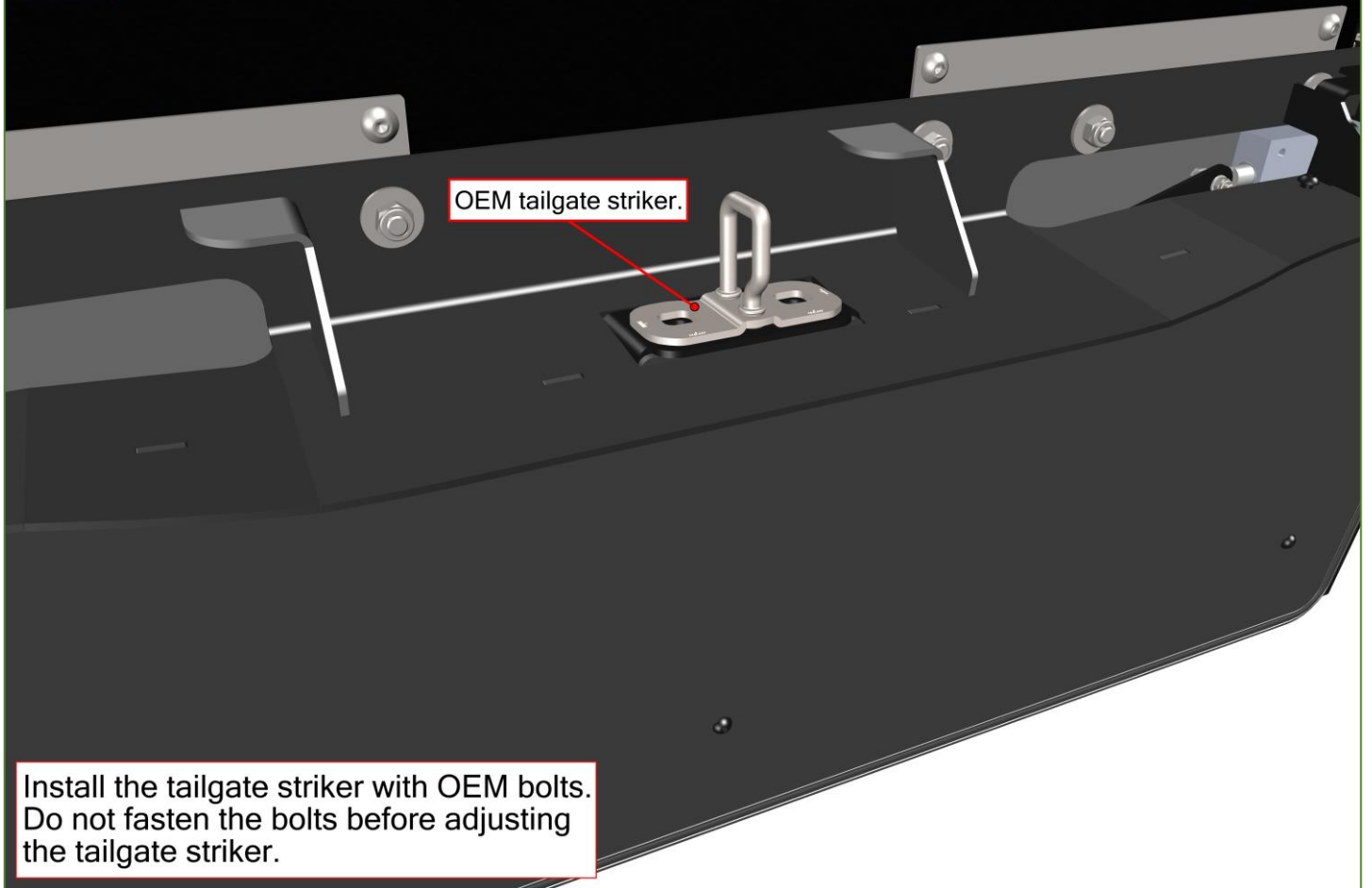

OEM tailgate striker.

Install the tailgate striker with OEM bolts.  
Do not fasten the bolts before adjusting  
the tailgate striker.

Ramp

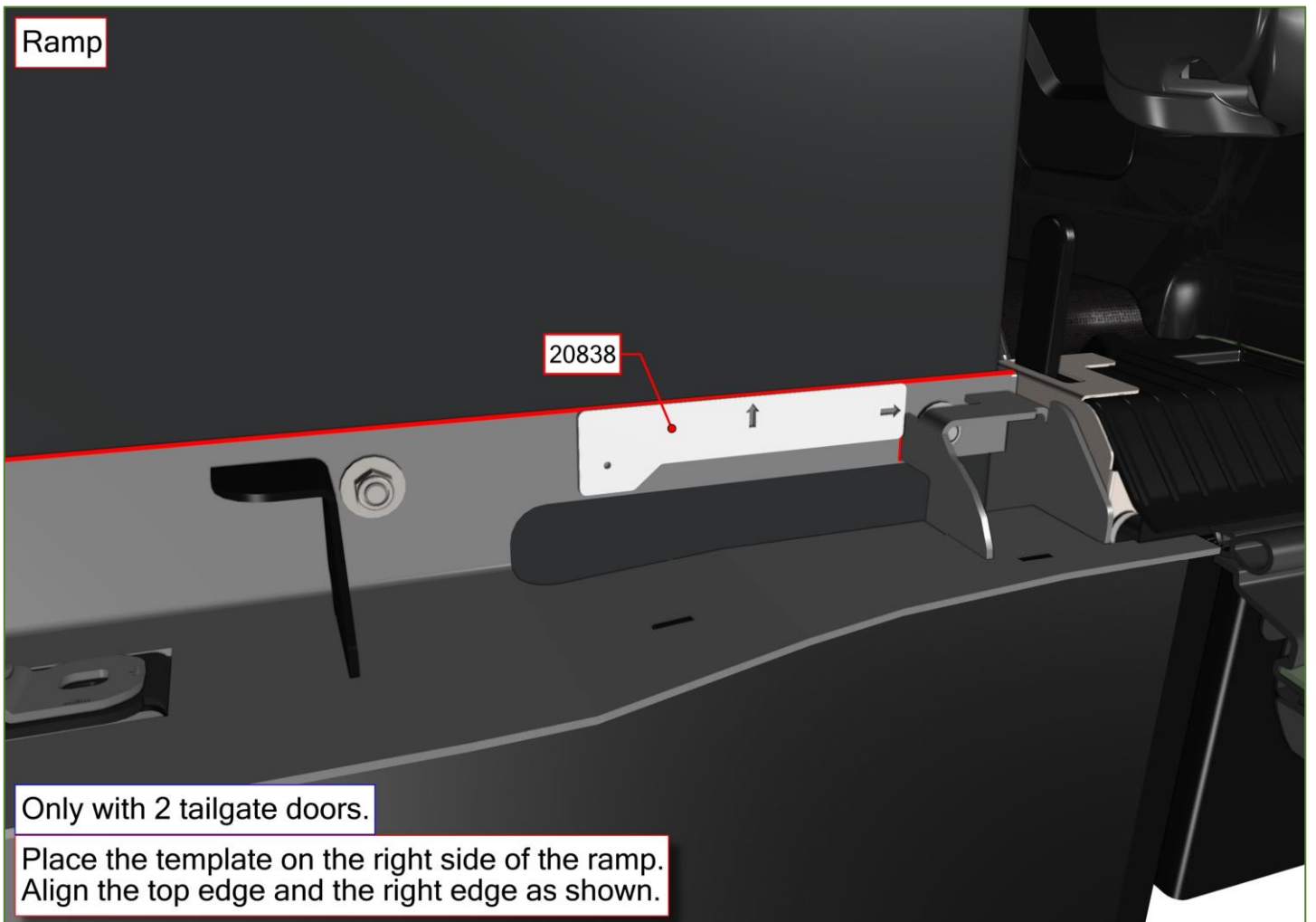

20838

Only with 2 tailgate doors.

Place the template on the right side of the ramp.  
Align the top edge and the right edge as shown.

Ramp

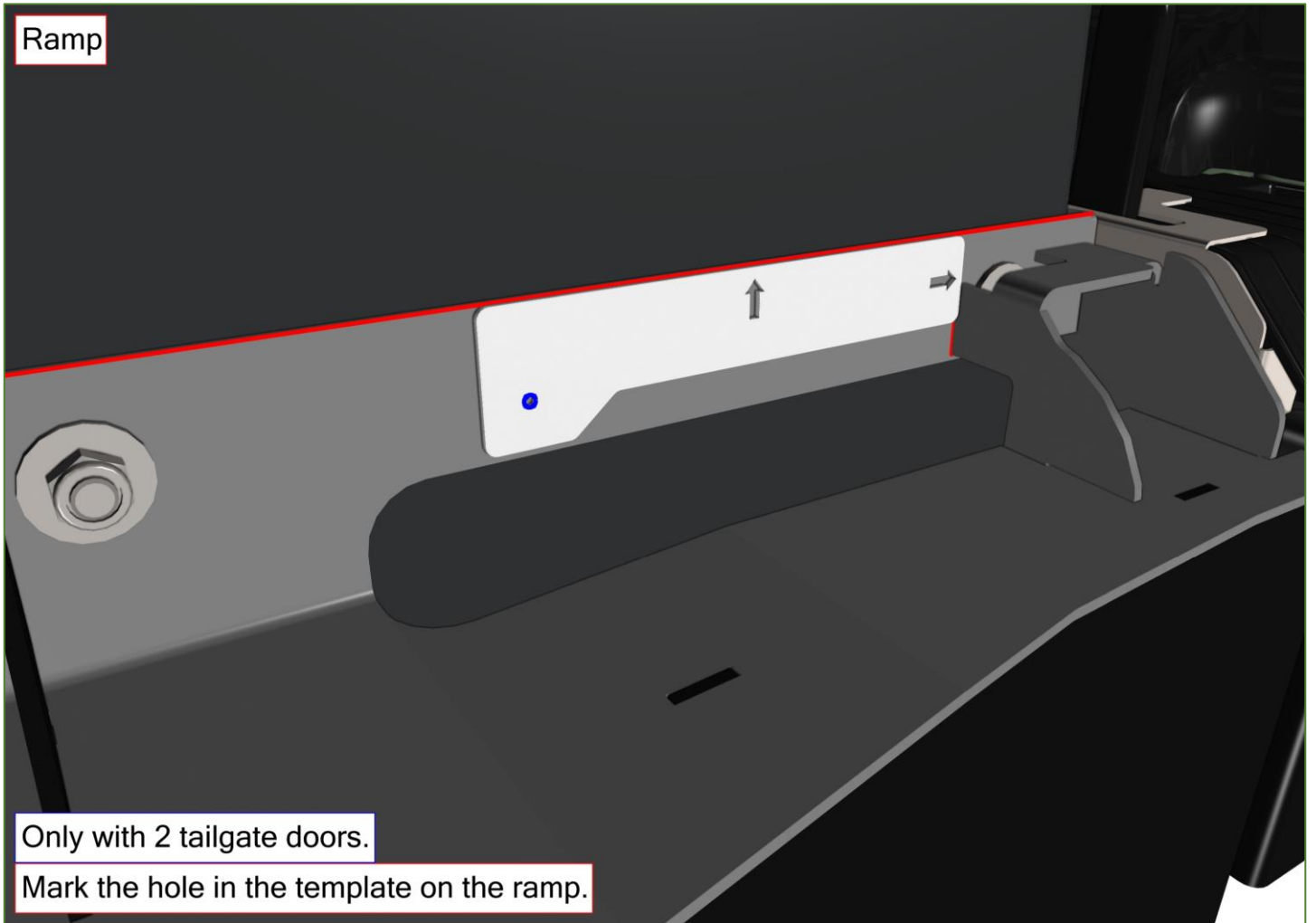

Only with 2 tailgate doors.

Mark the hole in the template on the ramp.

Ramp

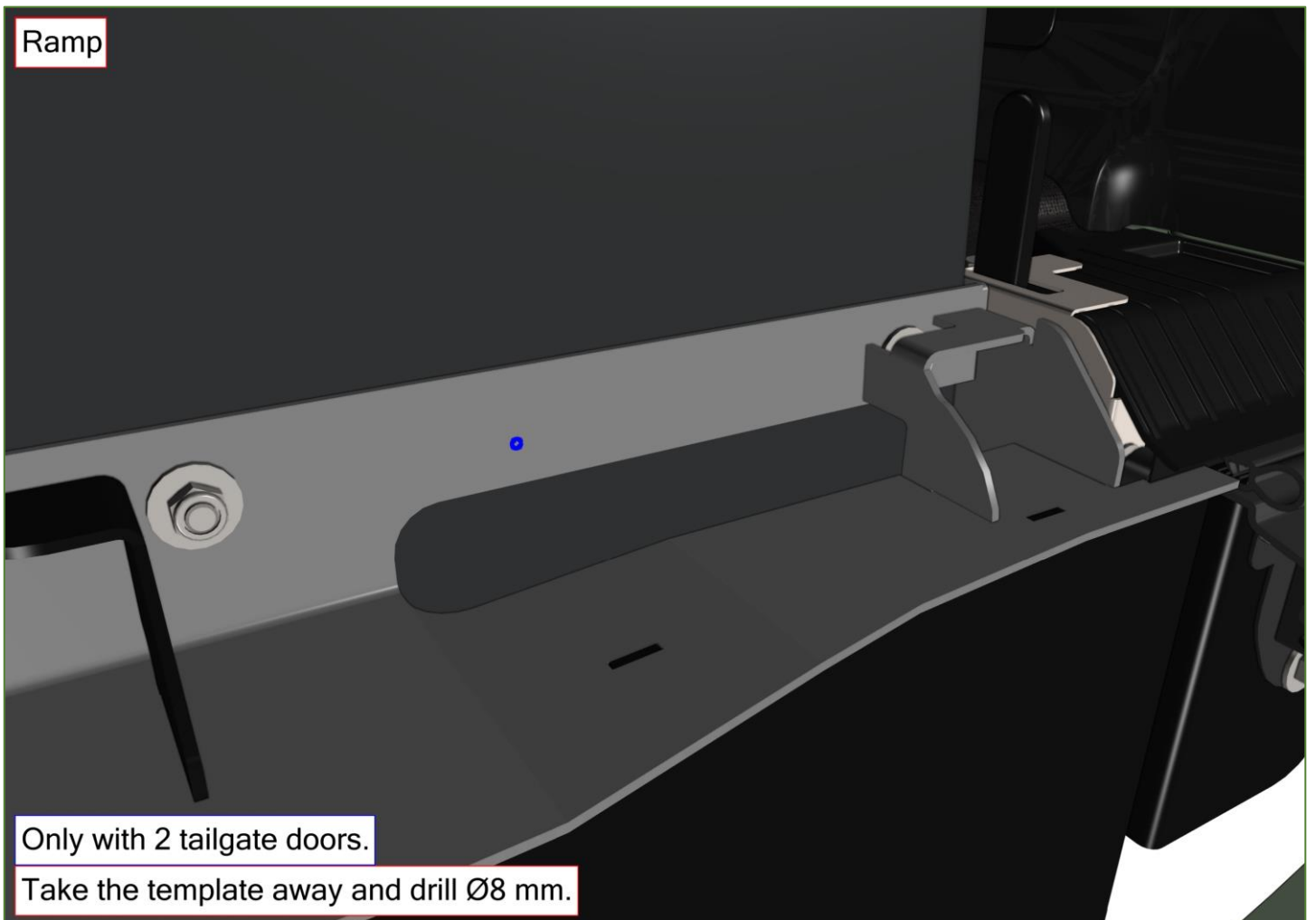

Only with 2 tailgate doors.

Take the template away and drill Ø8 mm.

Ramp

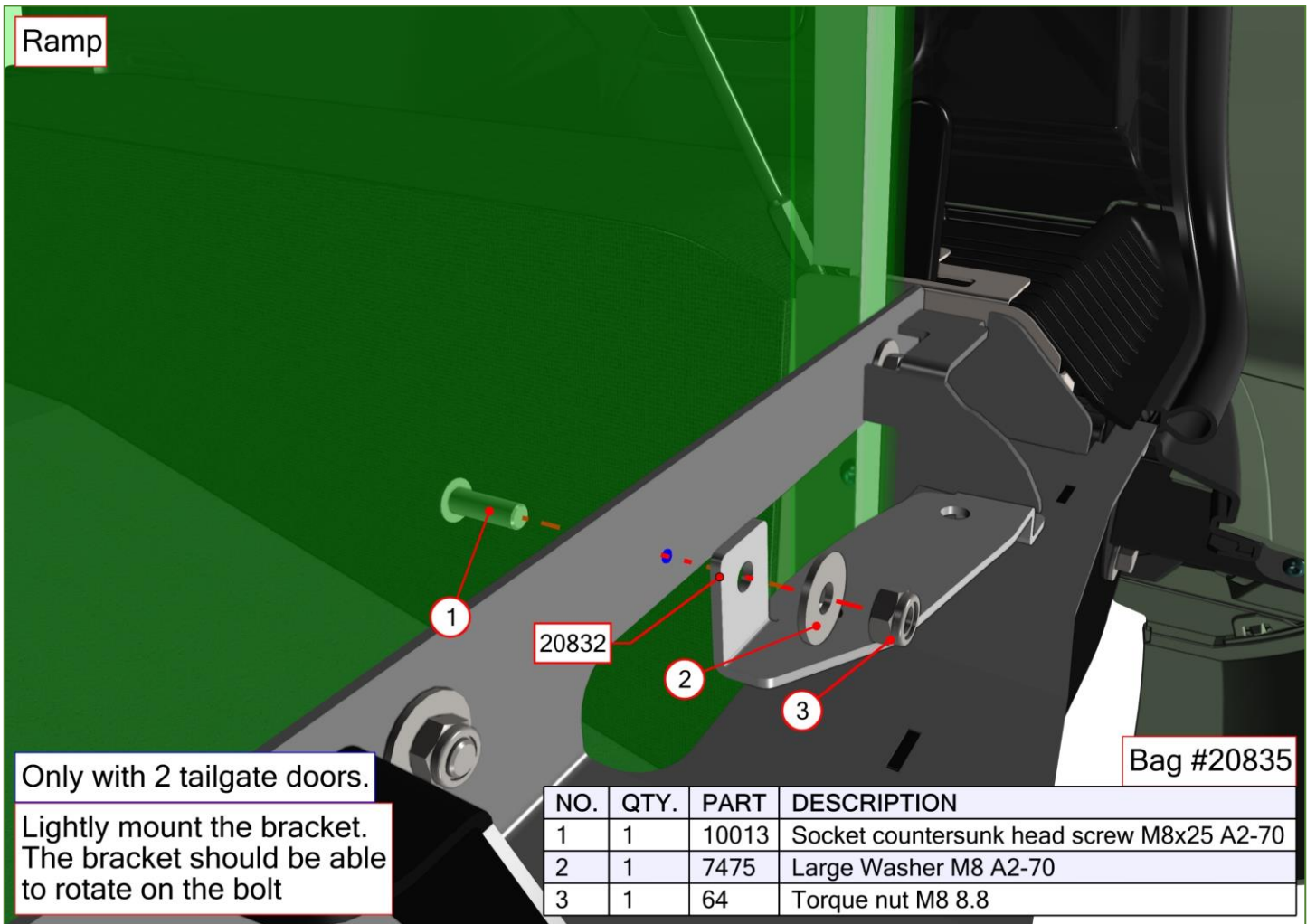

Only with 2 tailgate doors.

Lightly mount the bracket.  
The bracket should be able  
to rotate on the bolt

NO.	QTY.	PART	DESCRIPTION
1	1	10013	Socket countersunk head screw M8x25 A2-70
2	1	7475	Large Washer M8 A2-70
3	1	64	Torque nut M8 8.8

Ramp

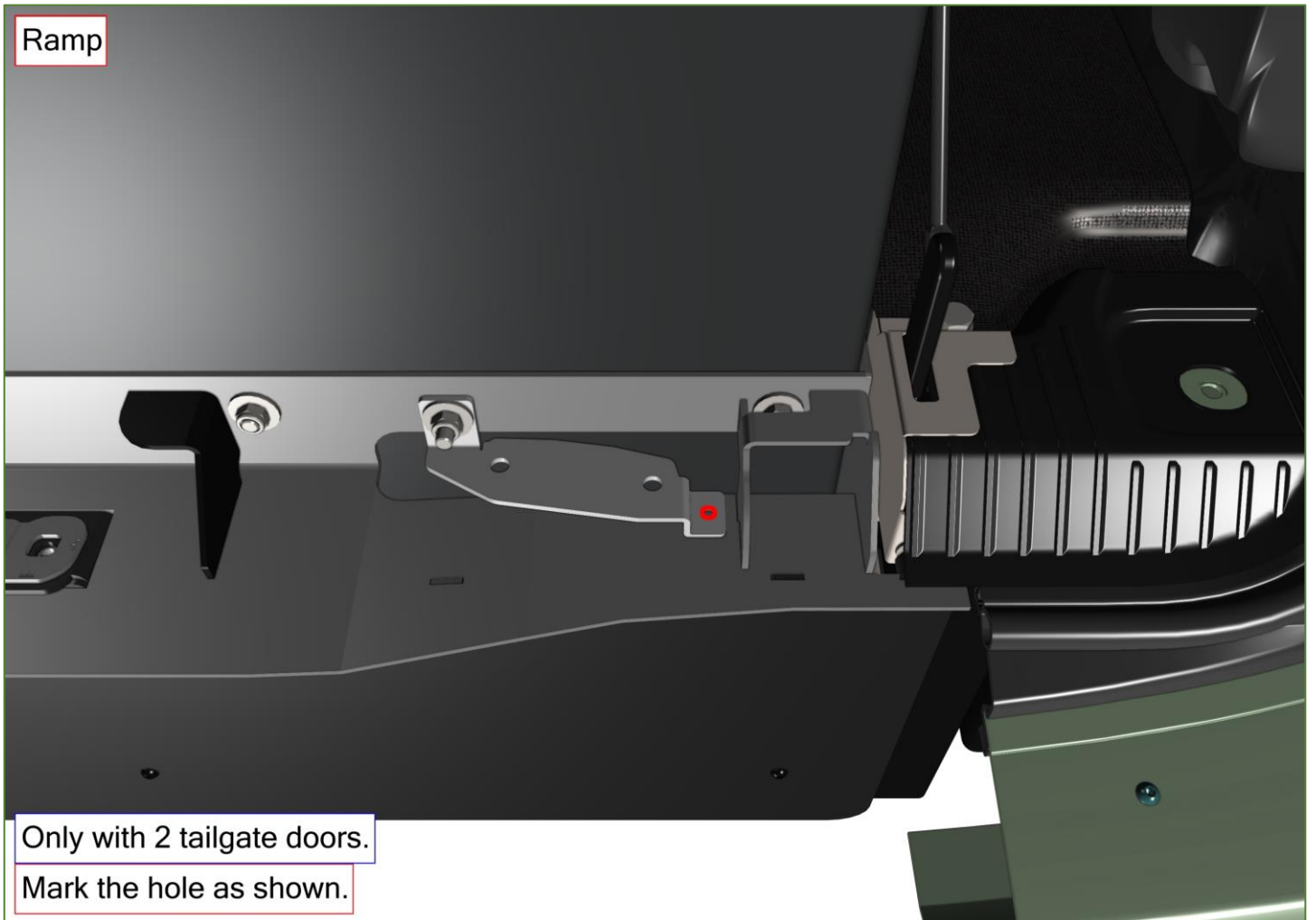

Only with 2 tailgate doors.

Mark the hole as shown.



Ramp

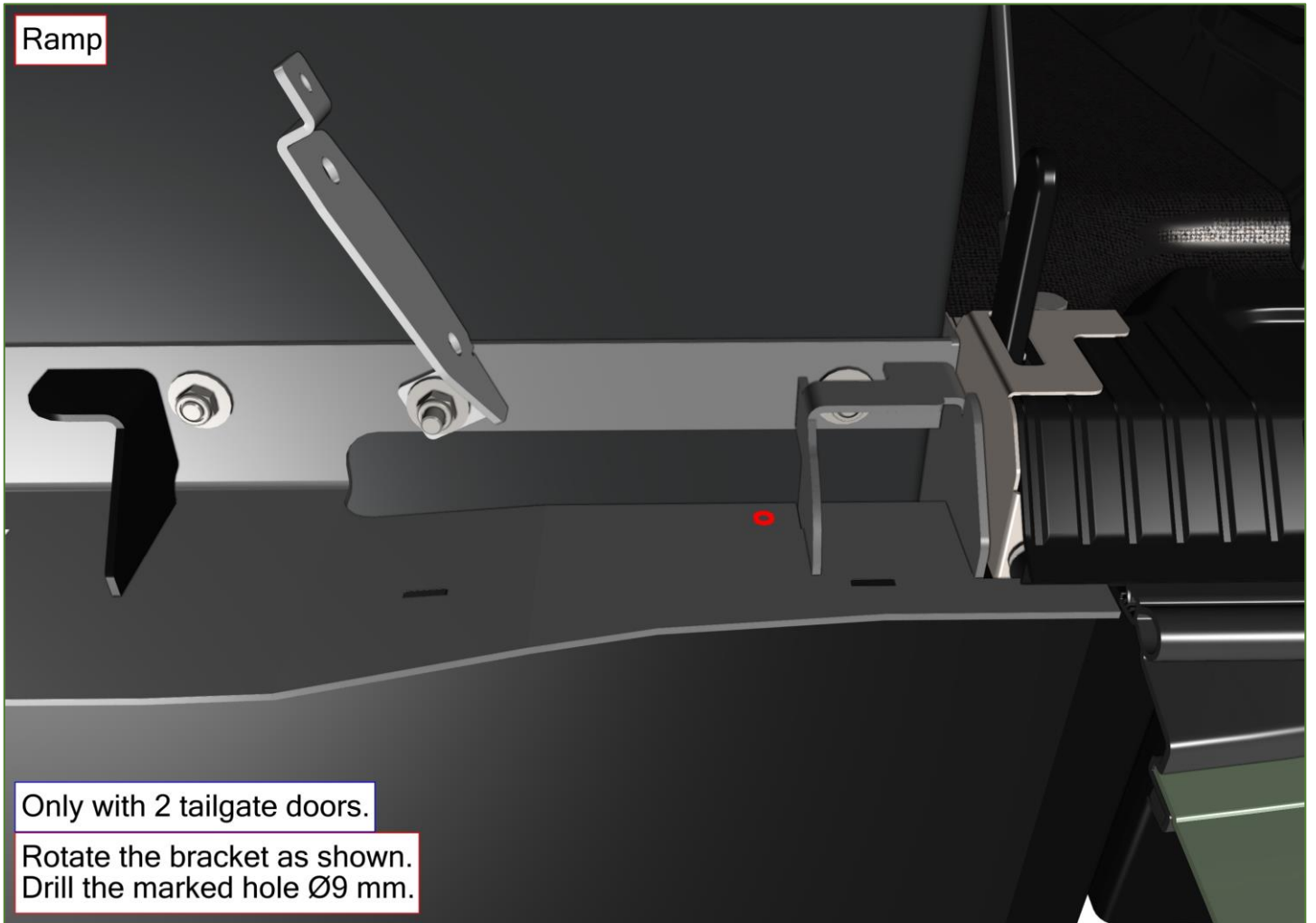

Only with 2 tailgate doors.

Rotate the bracket as shown.  
Drill the marked hole Ø9 mm.

Ramp

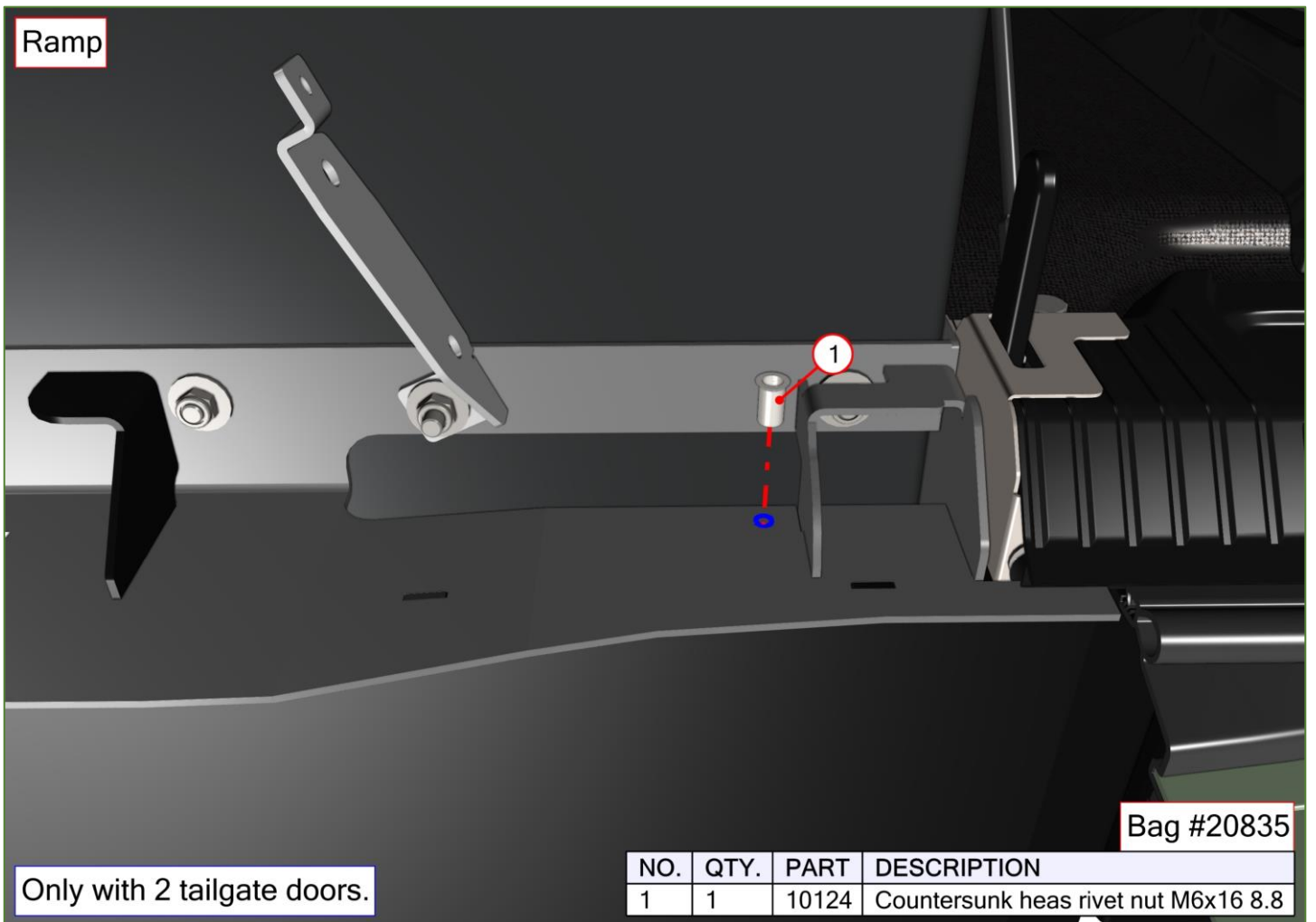

Bag #20835

Only with 2 tailgate doors.

NO.	QTY.	PART	DESCRIPTION
1	1	10124	Countersunk head rivet nut M6x16 8.8

Ramp

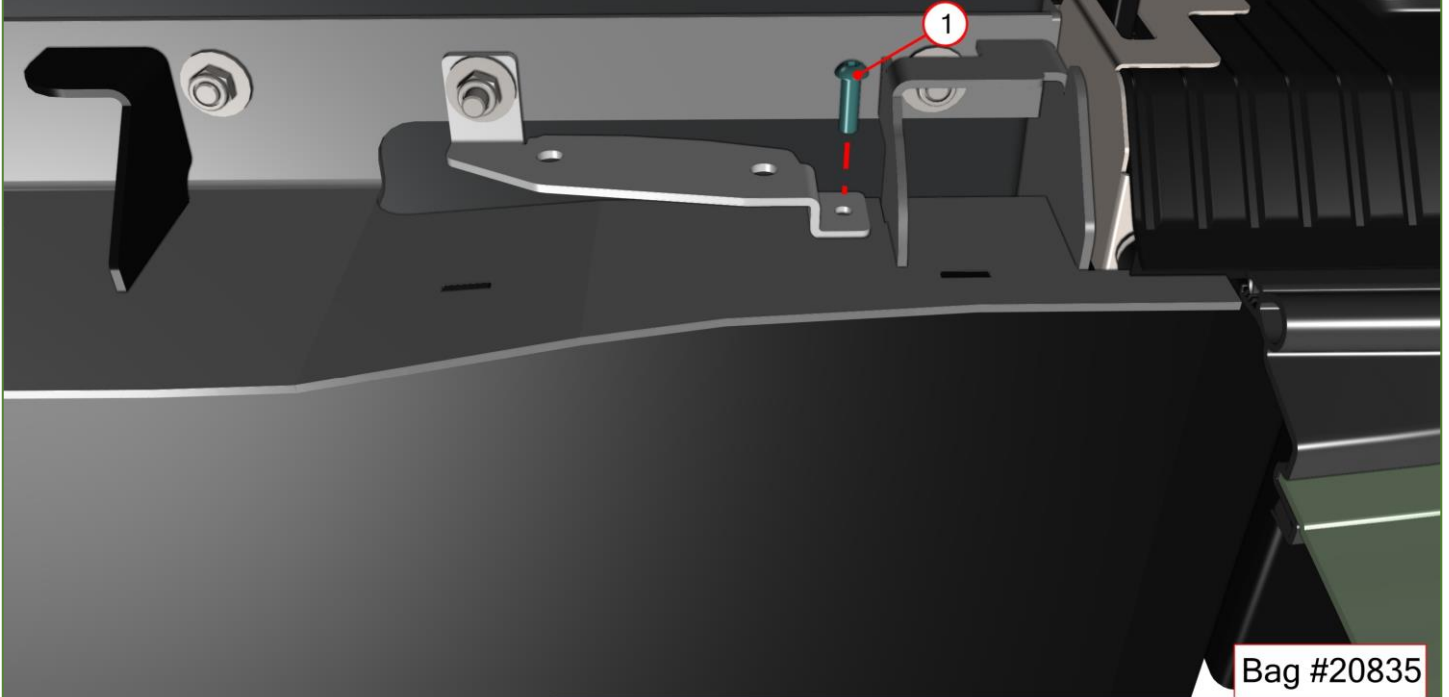

Bag #20835

Only with 2 tailgate doors.

NO.	QTY.	PART	DESCRIPTION
1	1	11655	Socket button head FLANGE screw M6x20 A2-70

Ramp

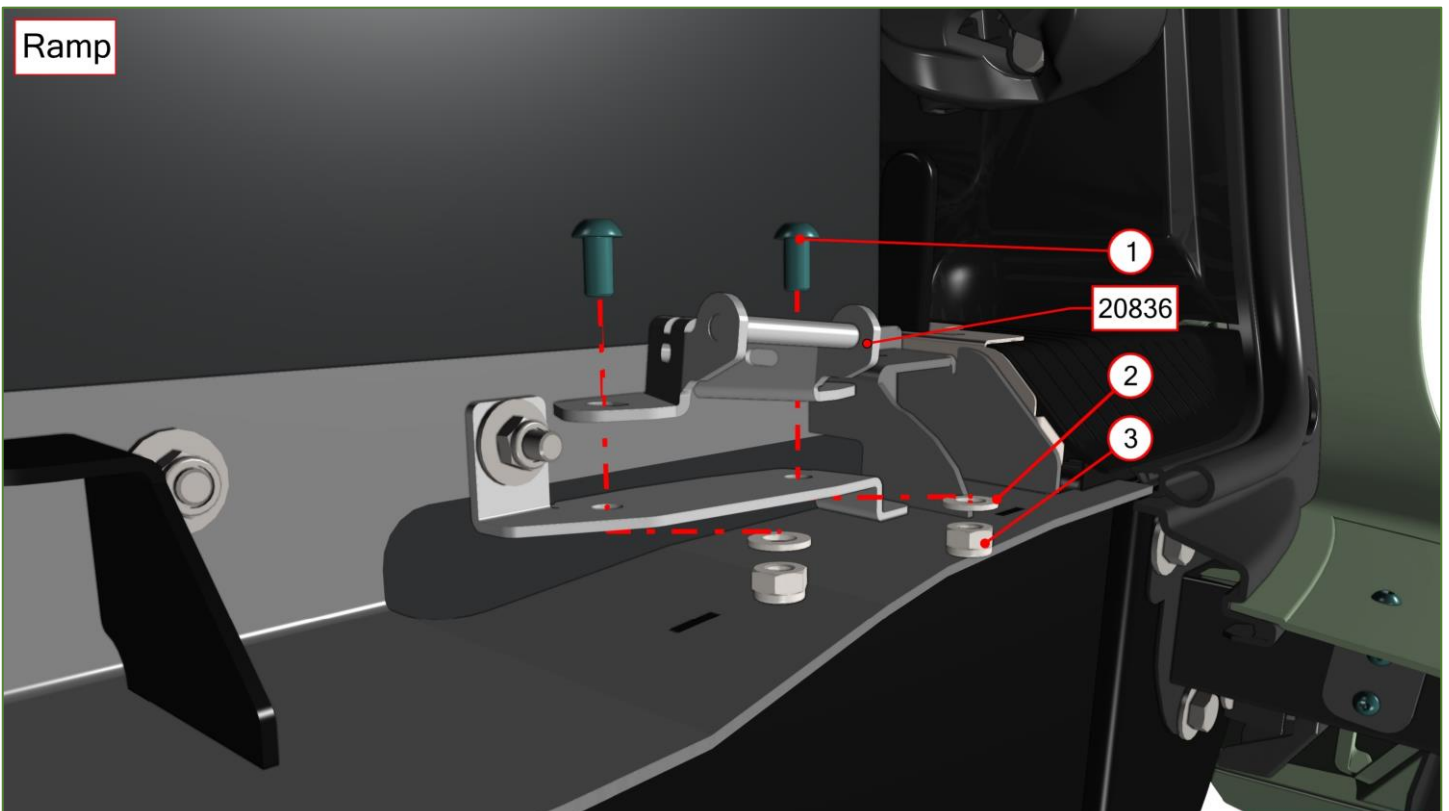

Bag #20835

Only with 2 tailgate doors.

NO.	QTY.	PART	DESCRIPTION
1	2	16066	Socket button head FLANGE screw M8x16 A2-70
2	2	8081	Washer M8 A2-70
3	2	64	Torque nut M8 8.8

## Ramp

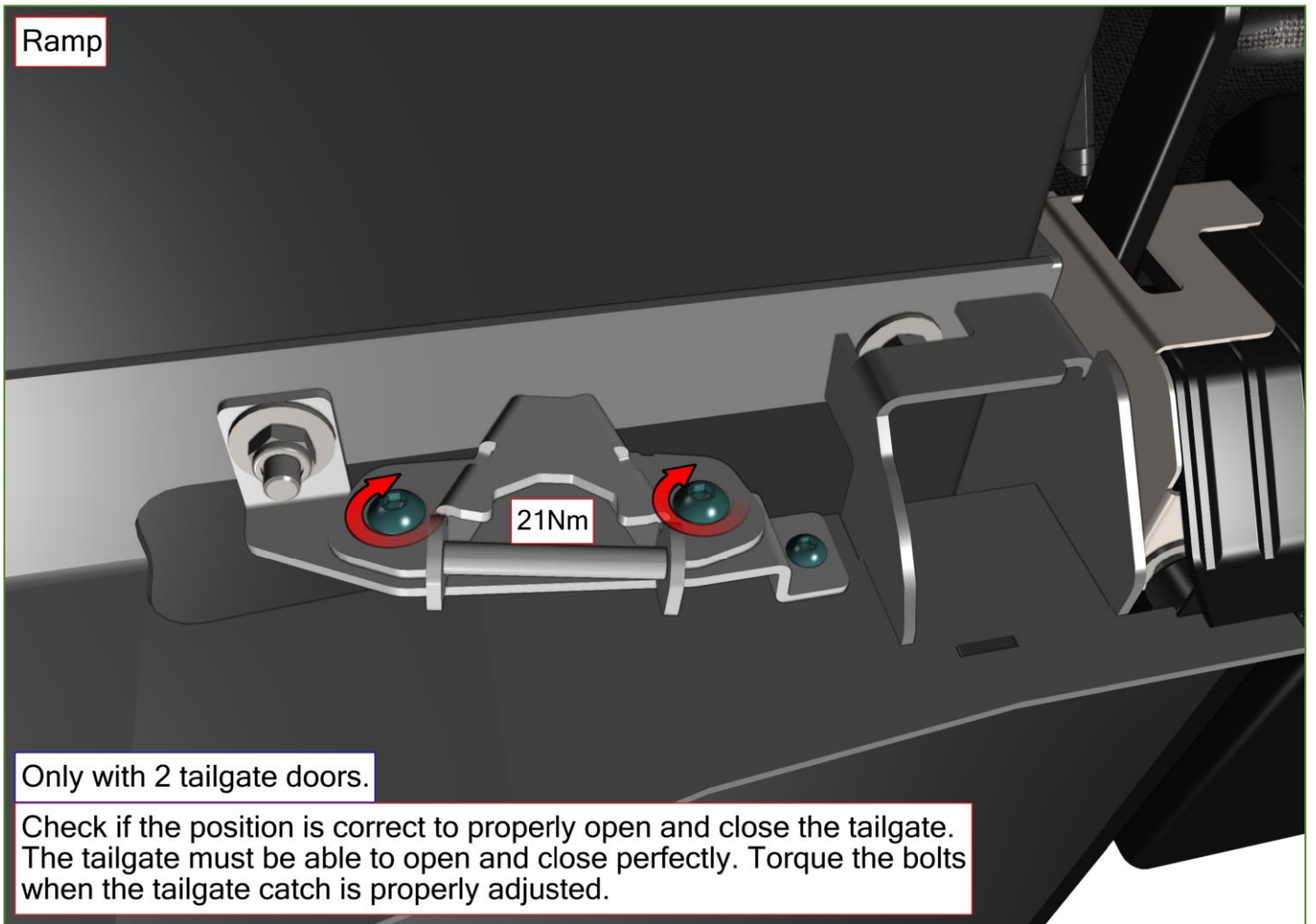

Only with 2 tailgate doors.

Check if the position is correct to properly open and close the tailgate. The tailgate must be able to open and close perfectly. Torque the bolts when the tailgate catch is properly adjusted.

## Ramp

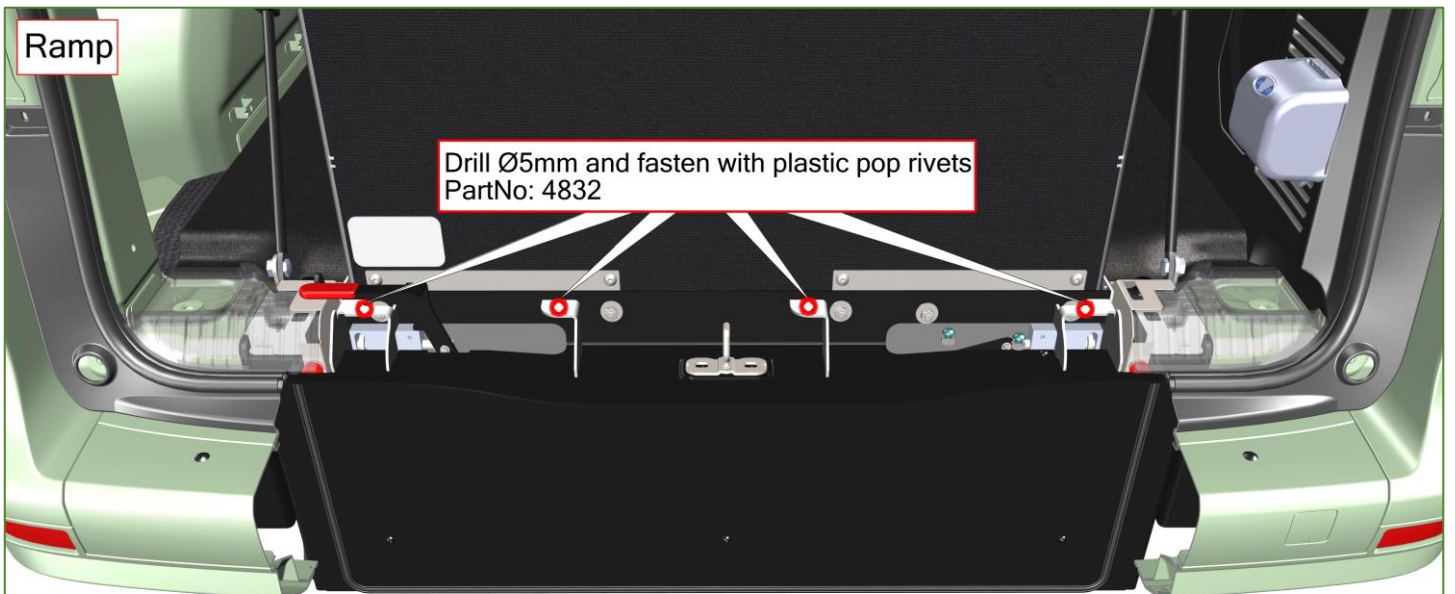

Install the rear cover on the ramp. Make sure the fitment is good. If not, remove any plastic necessary.



2nd row OEM seats

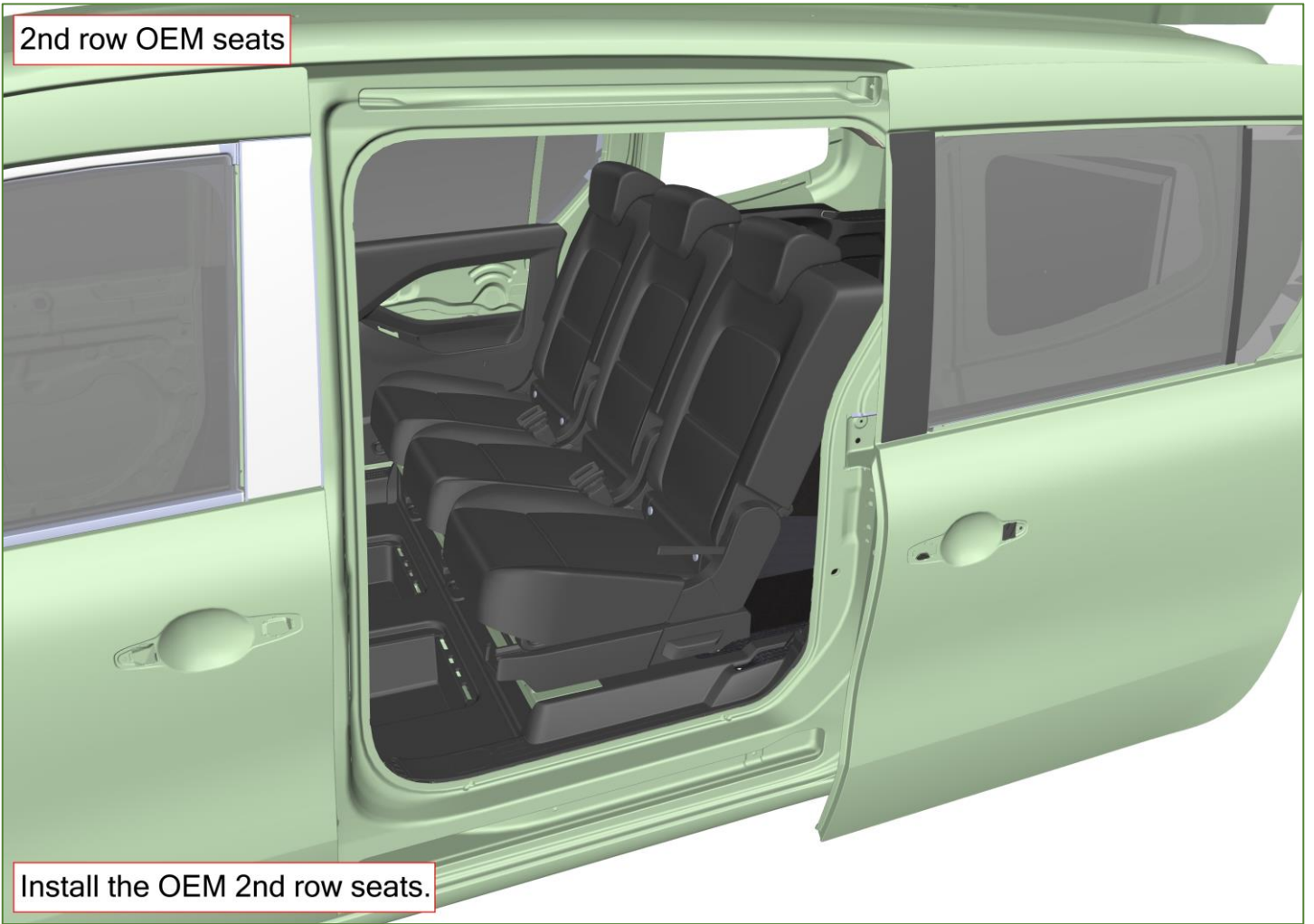

Install the OEM 2nd row seats.

3rd row TriflexAir seats



Remove the rear cover of the TriflexAIR seat, then remove the swivel plate.

3rd row TriflexAir seats

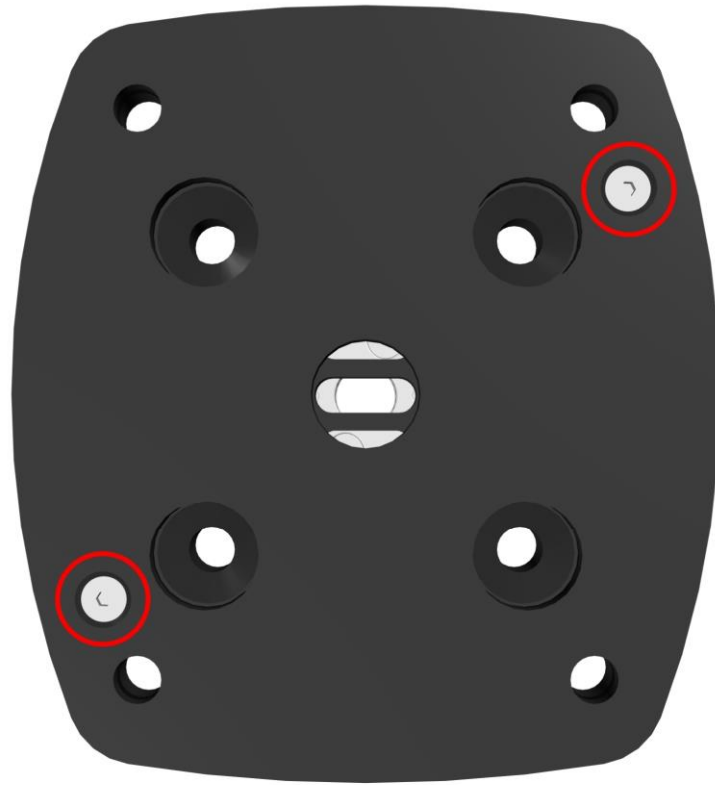

Remove the bottom of the swivel plate by taking the marked bolts out. If one of the bolts doesn't come loose, follow the next step.

3rd row TriflexAir seats

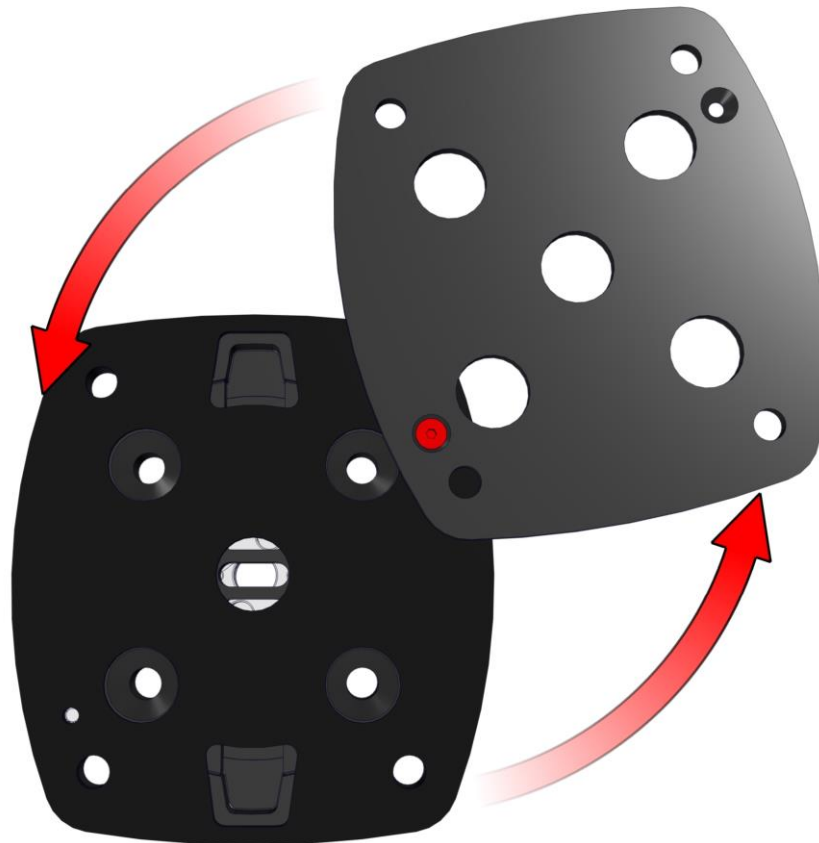

If one of the bolts won't come loose, try the other bolt and use the bottom part to rotate the stuck bolt to open the swivel plate as shown.

3rd row TriflexAir seats

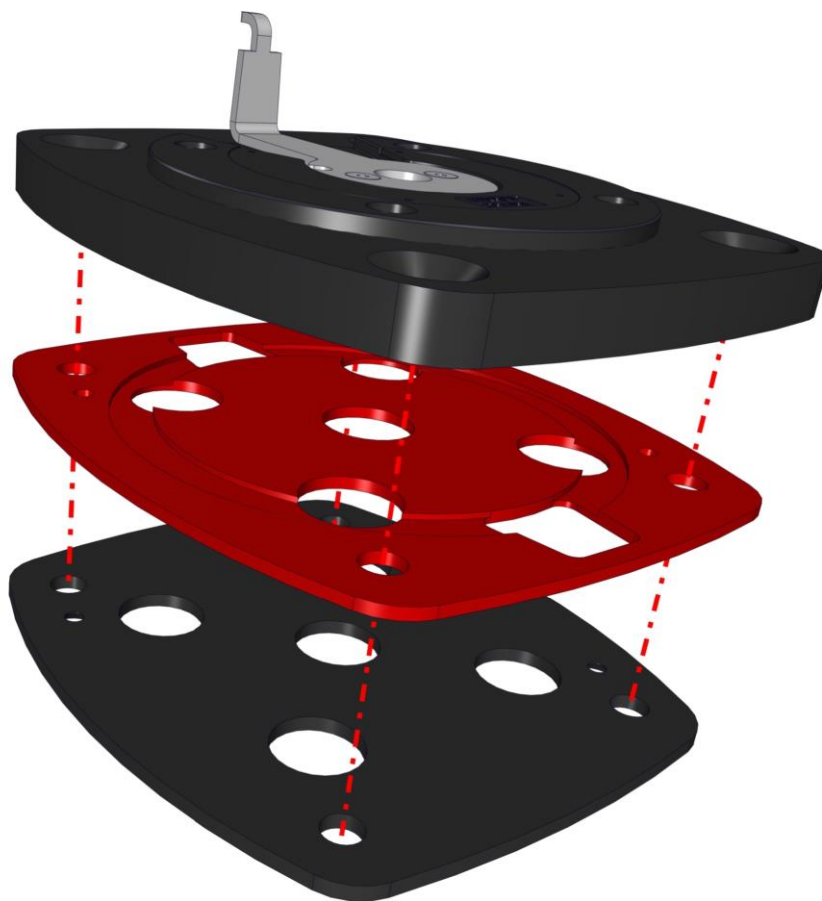

Remove the thin plate from the bottom and take out the alignment plate.

3rd row TriflexAir seats

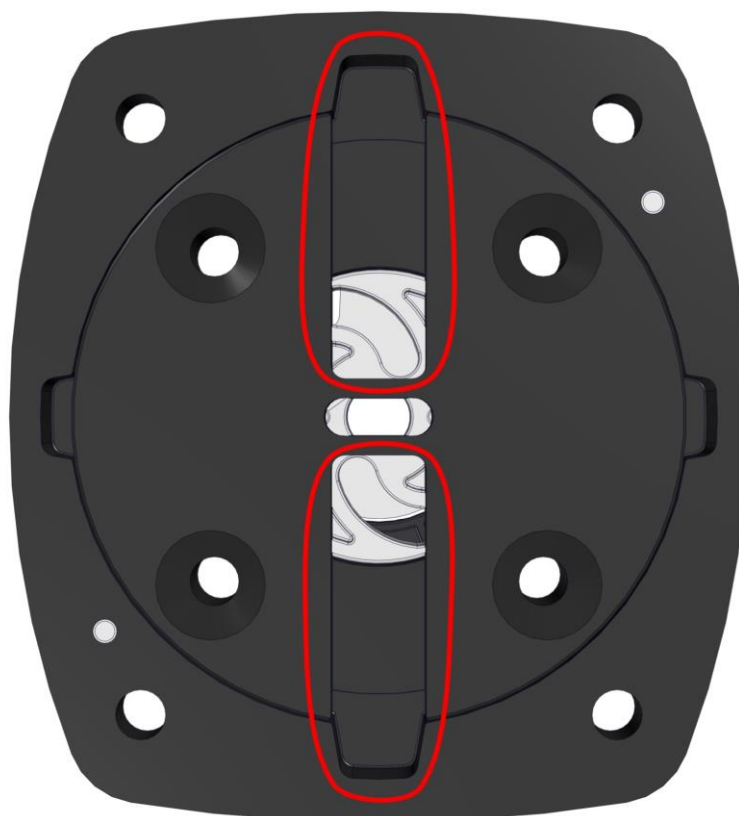

In the marked slots there are 2 strips, take these out.



3rd row TriflexAir seats

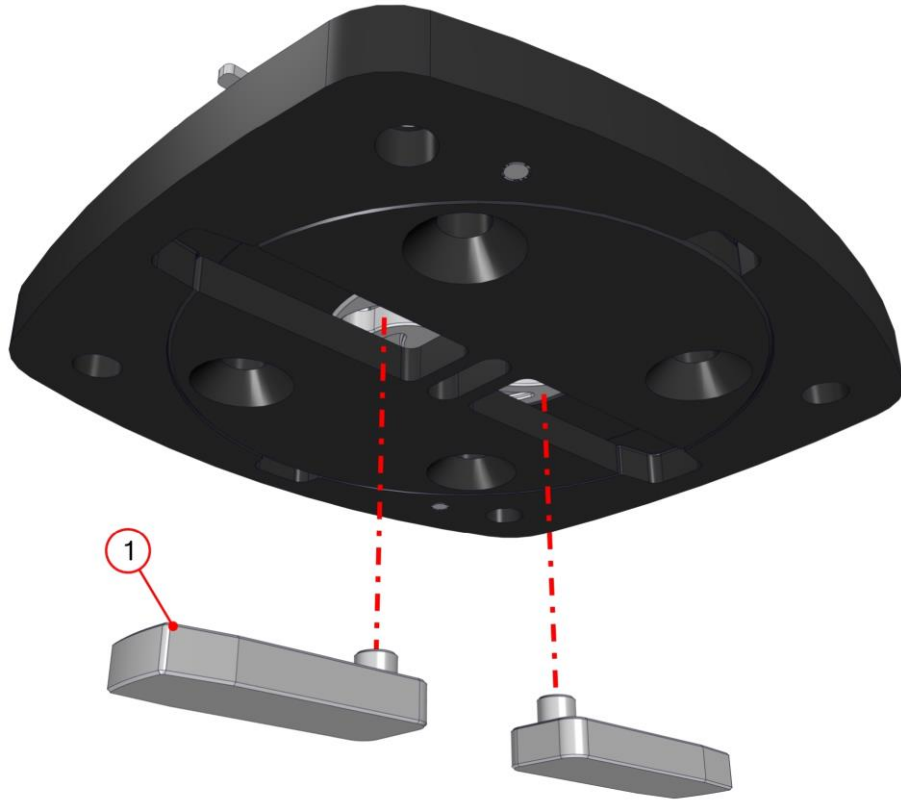

Bag #21515

Install the new lock strips.

NO.	QTY.	PART	DESCRIPTION
1	2	20262	TriflexAIR lock strip

3rd row TriflexAir seats

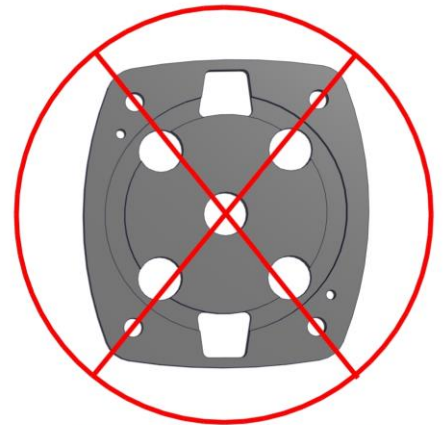
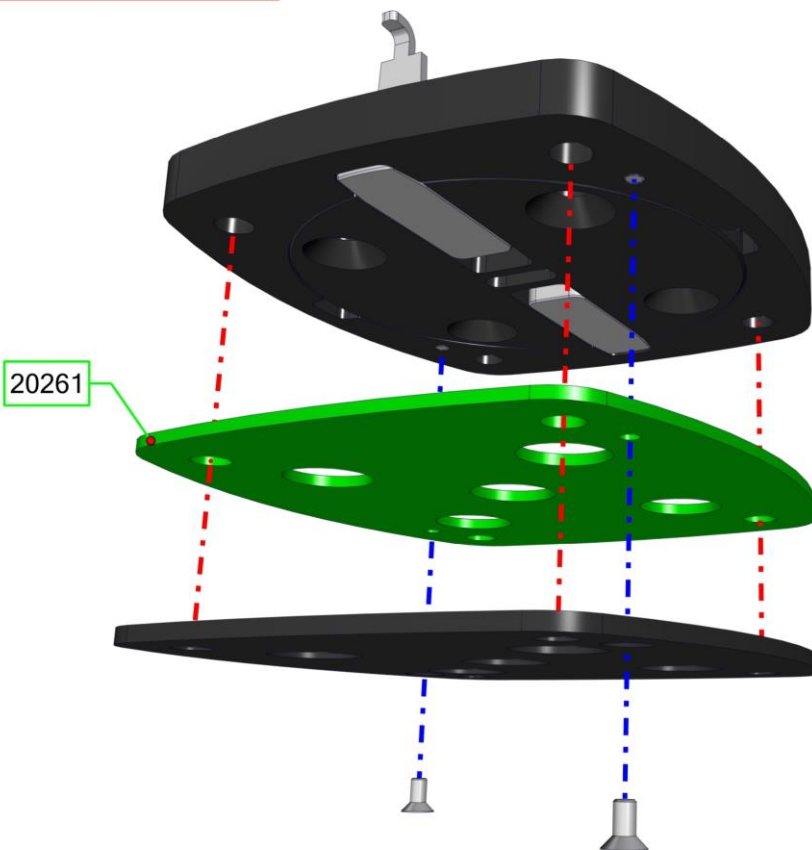

Be sure to NOT use the original alignment plate.

Reassemble the TriflexAir swivel plate with the NEW alignment plate.

3rd row TriflexAir seats

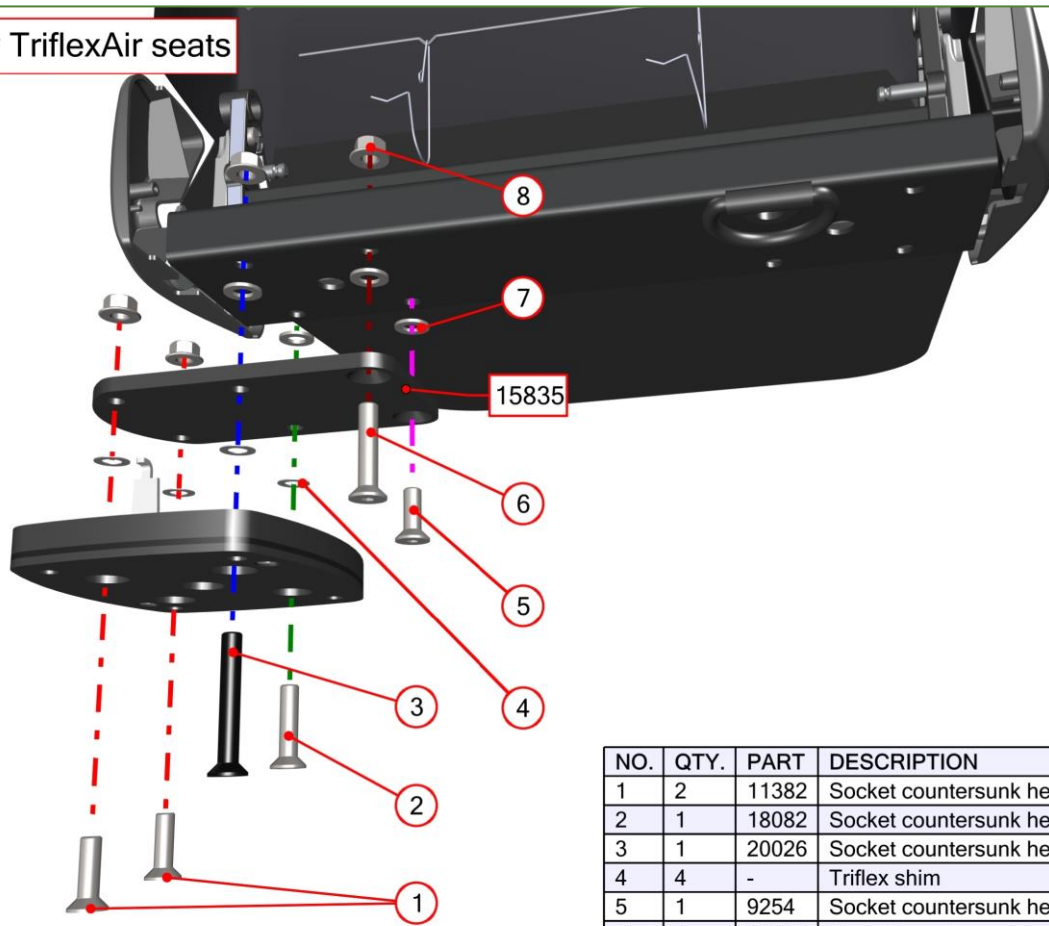

Bag #21491

NO.	QTY.	PART	DESCRIPTION
1	2	11382	Socket countersunk head screw M10x35 010.9
2	1	18082	Socket countersunk head screw M10x45 010.9
3	1	20026	Socket countersunk head screw M10x70 012.9
4	4	-	Triflex shim
5	1	9254	Socket countersunk head screw M10x30 010.9
6	1	11954	Socket countersunk head screw M10x50 010.9
7	4	173	Washer M10 8.8
8	4	11339	Hex flange nut M10 10.9

3rd row TriflexAir seats

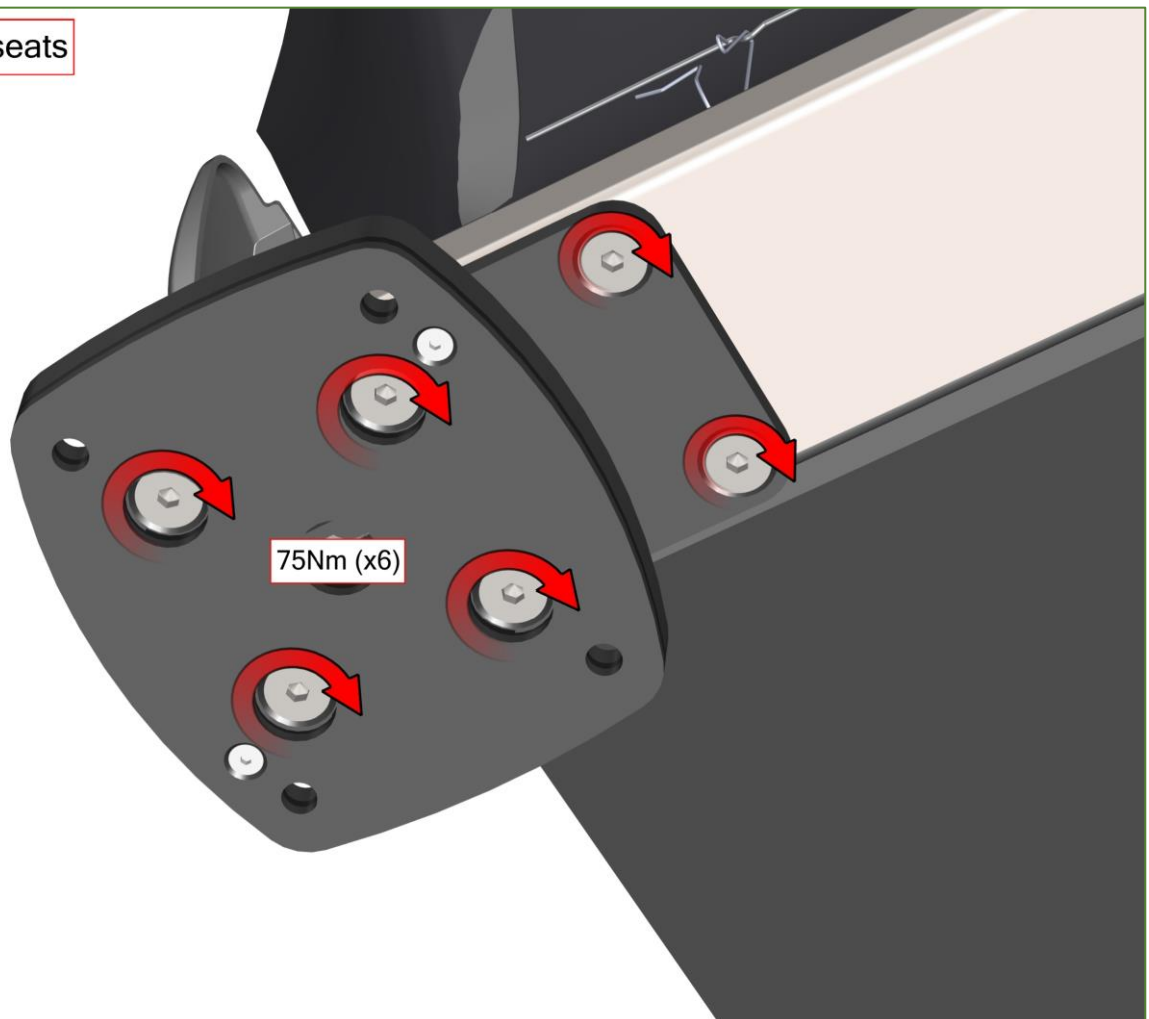

3rd row TriflexAir seats

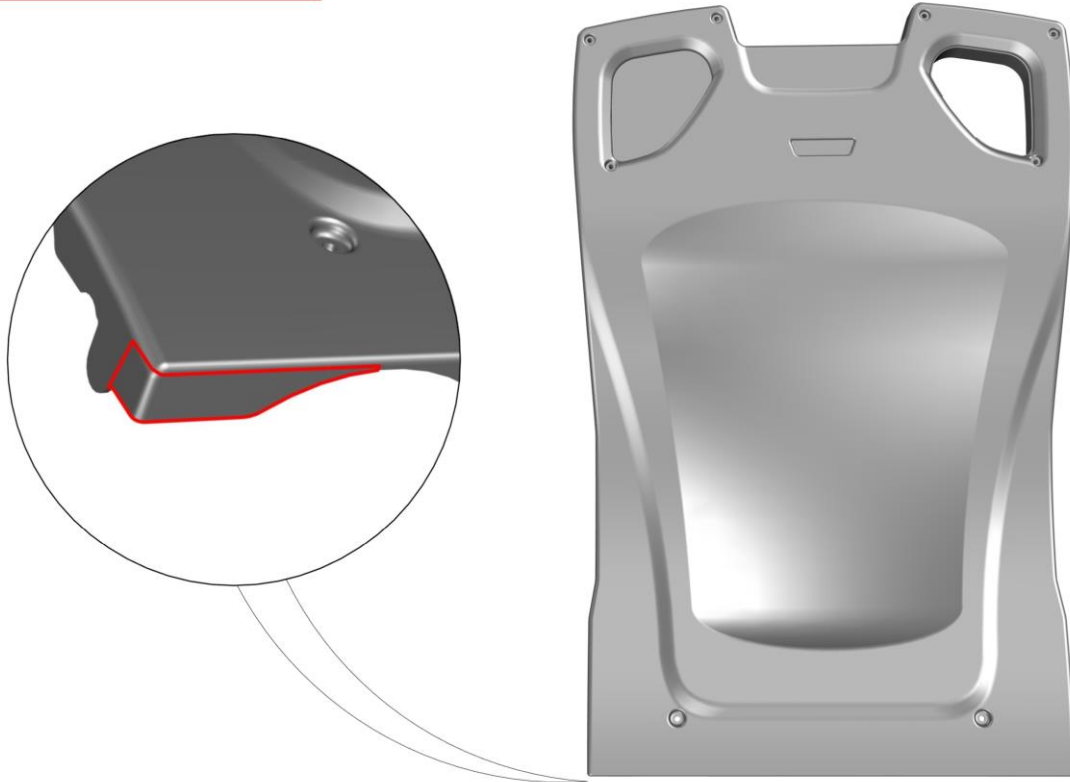

Cut the outside bottom corner as shown to make more room for the bent locking pawl.

3rd row TriflexAir seats

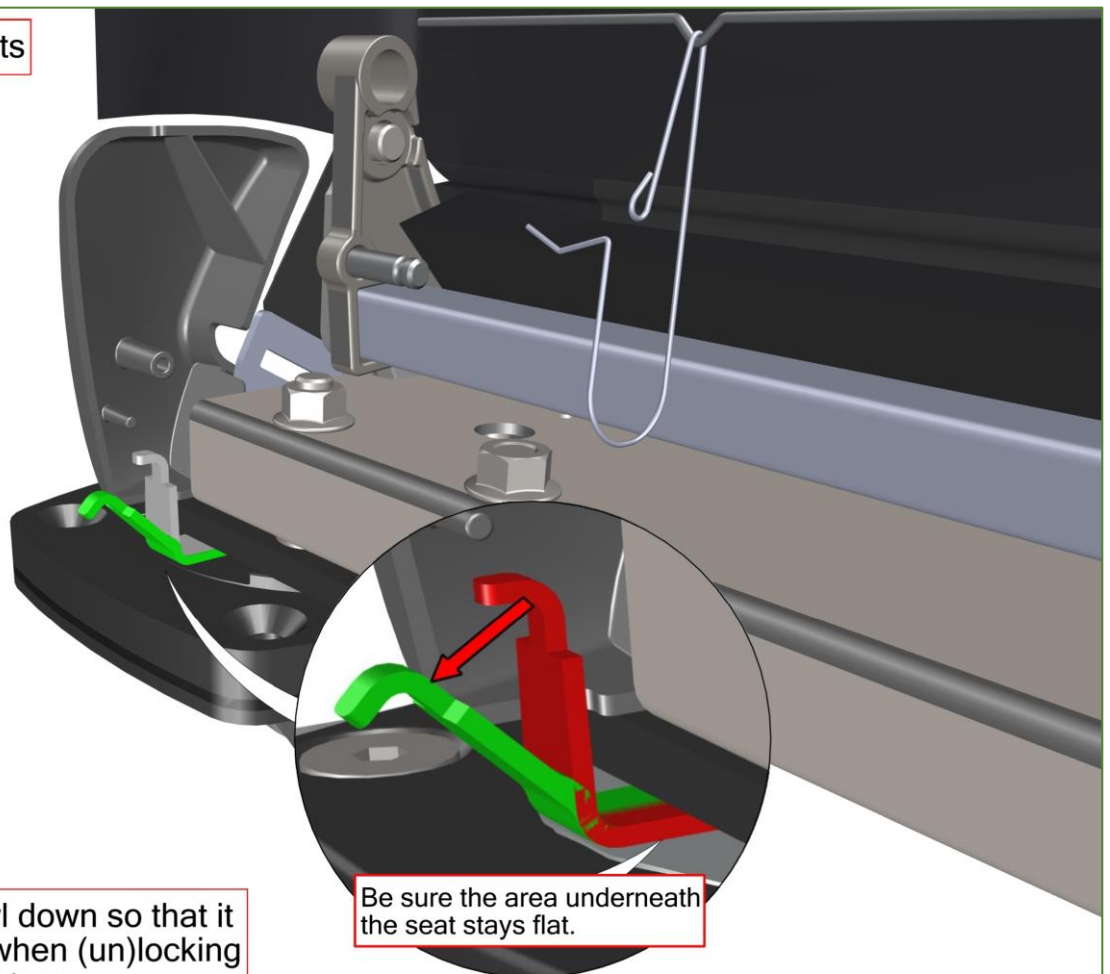

Bend the locking pawl down so that it clears all the covers when (un)locking and can make the full turn.

Be sure the area underneath the seat stays flat.



3rd row TriflexAir seats

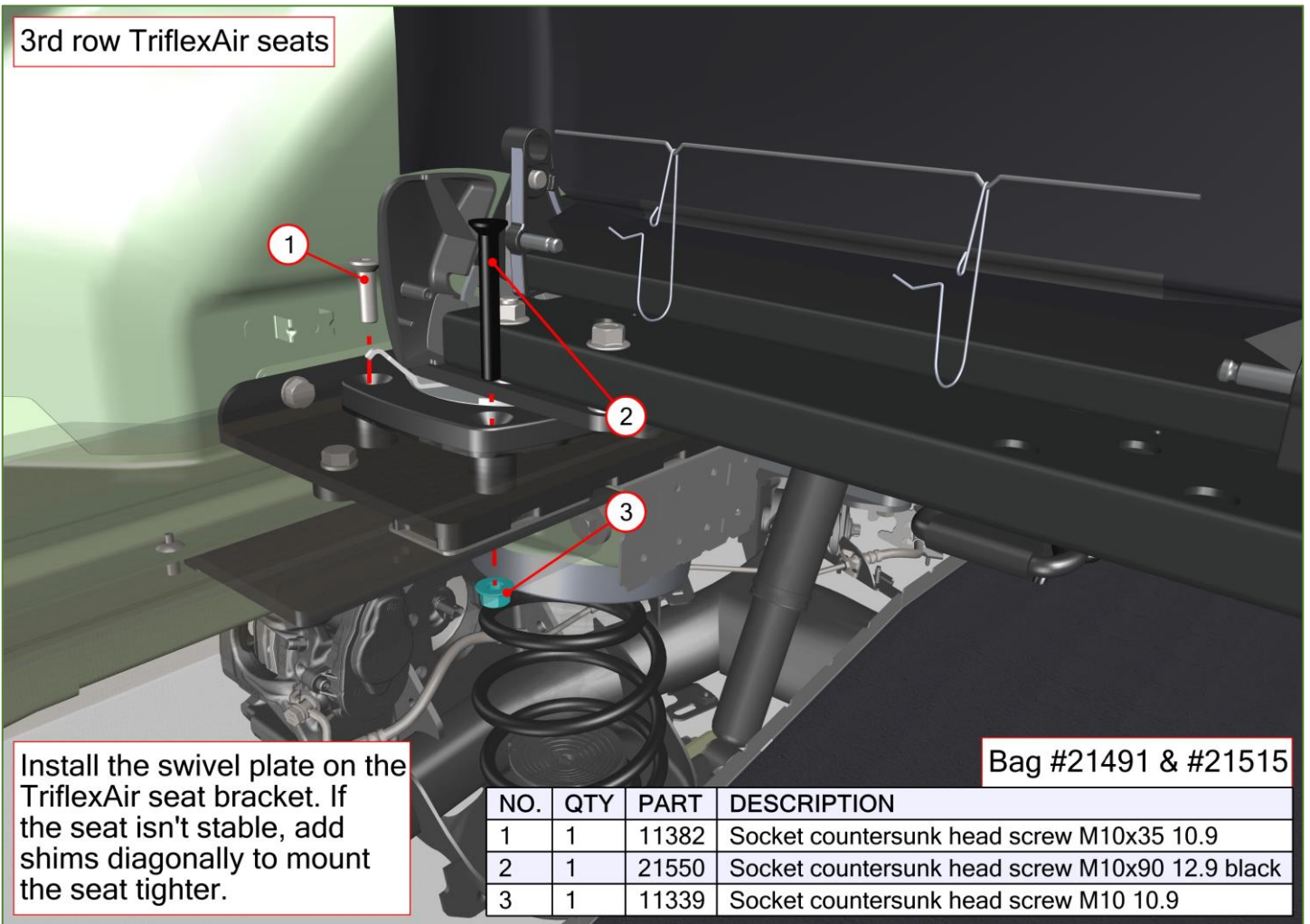

Install the swivel plate on the TriflexAir seat bracket. If the seat isn't stable, add shims diagonally to mount the seat tighter.

Bag #21491 & #21515

NO.	QTY	PART	DESCRIPTION
1	1	11382	Socket countersunk head screw M10x35 10.9
2	1	21550	Socket countersunk head screw M10x90 12.9 black
3	1	11339	Socket countersunk head screw M10 10.9

3rd row TriflexAir seats

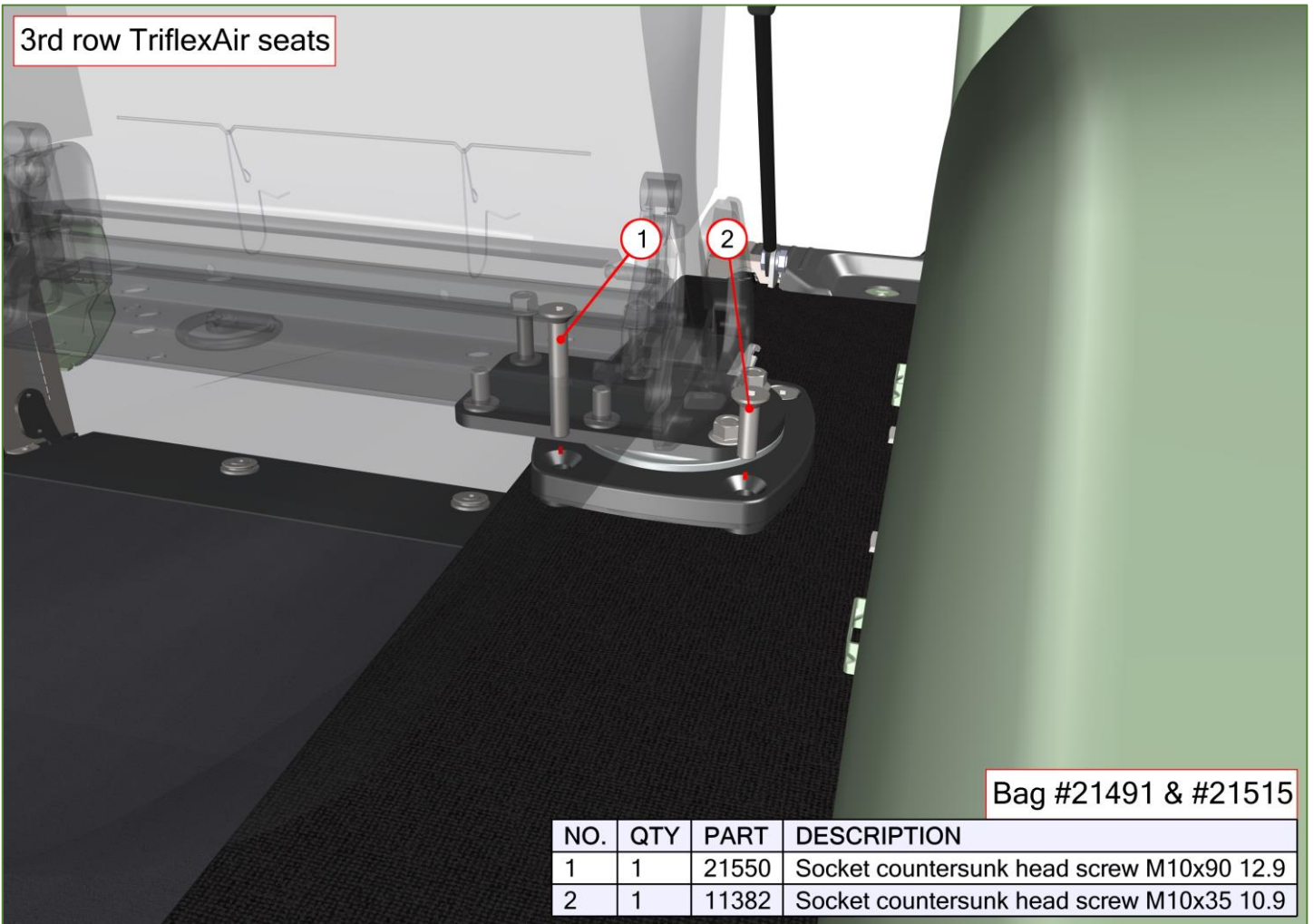

Bag #21491 & #21515

NO.	QTY	PART	DESCRIPTION
1	1	21550	Socket countersunk head screw M10x90 12.9
2	1	11382	Socket countersunk head screw M10x35 10.9

3rd row TriflexAir seats

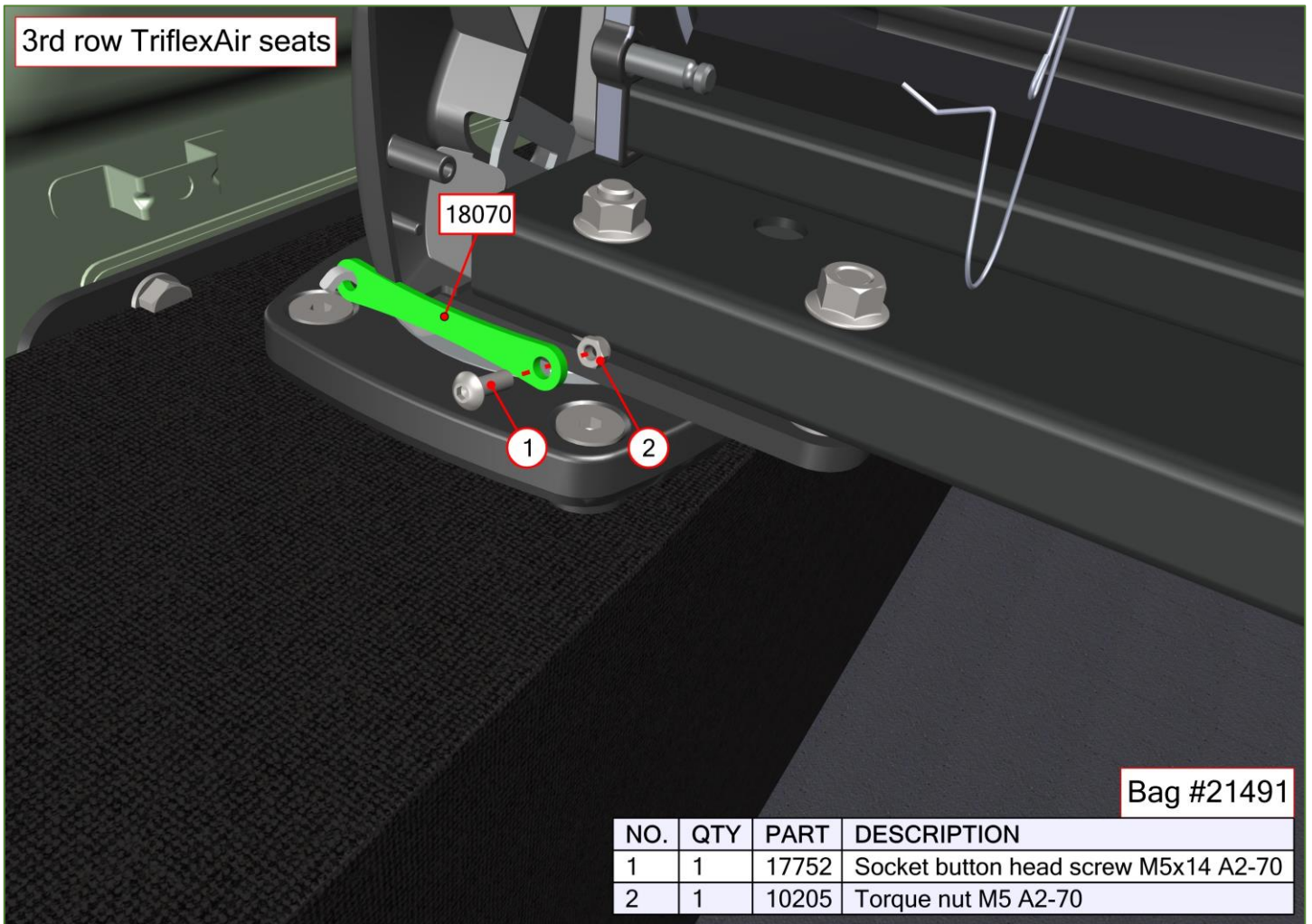

Bag #21491

NO.	QTY	PART	DESCRIPTION
1	1	17752	Socket button head screw M5x14 A2-70
2	1	10205	Torque nut M5 A2-70

3rd row TriflexAir seats



Make sure the (un)locking mechanism functions properly and does not hook on any of the covers. Also make sure there is absolutely no play.



3rd row TriflexAir seats

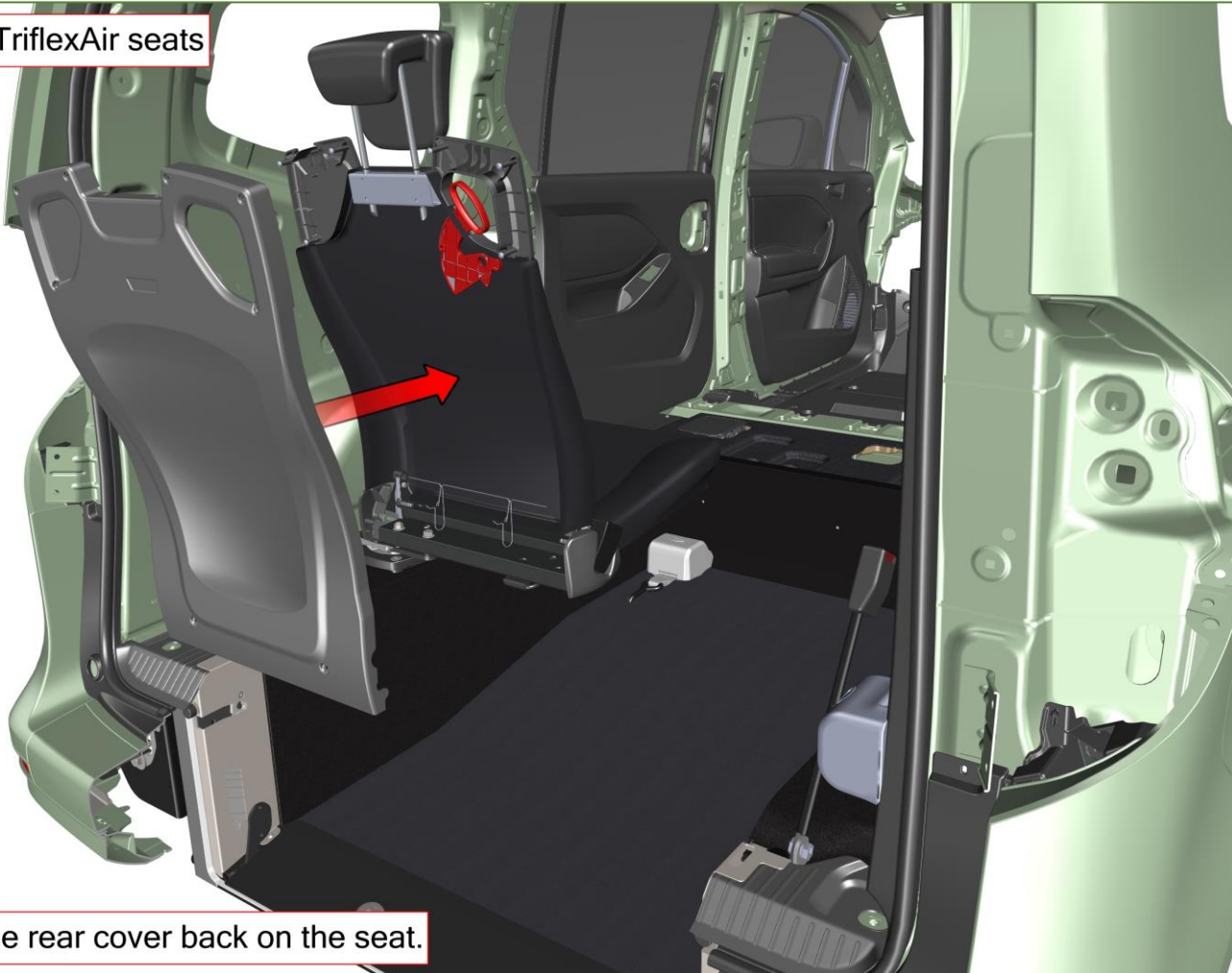

Mount the rear cover back on the seat.

Taillights



Reinstall the taillights.



Rear bumper



Replace the gas struts with the new ones.

Rear bumper

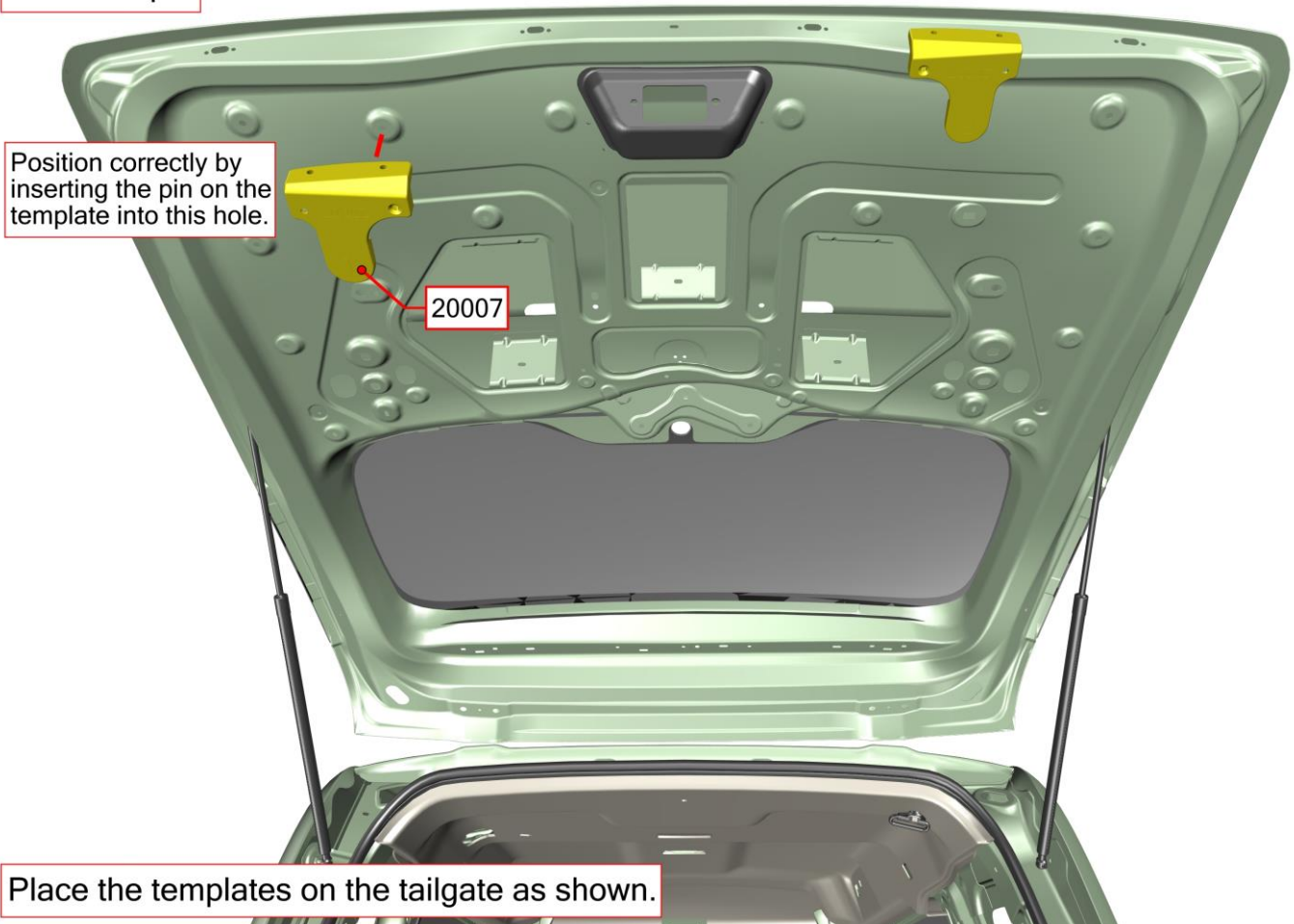

Place the templates on the tailgate as shown.

Rear bumper

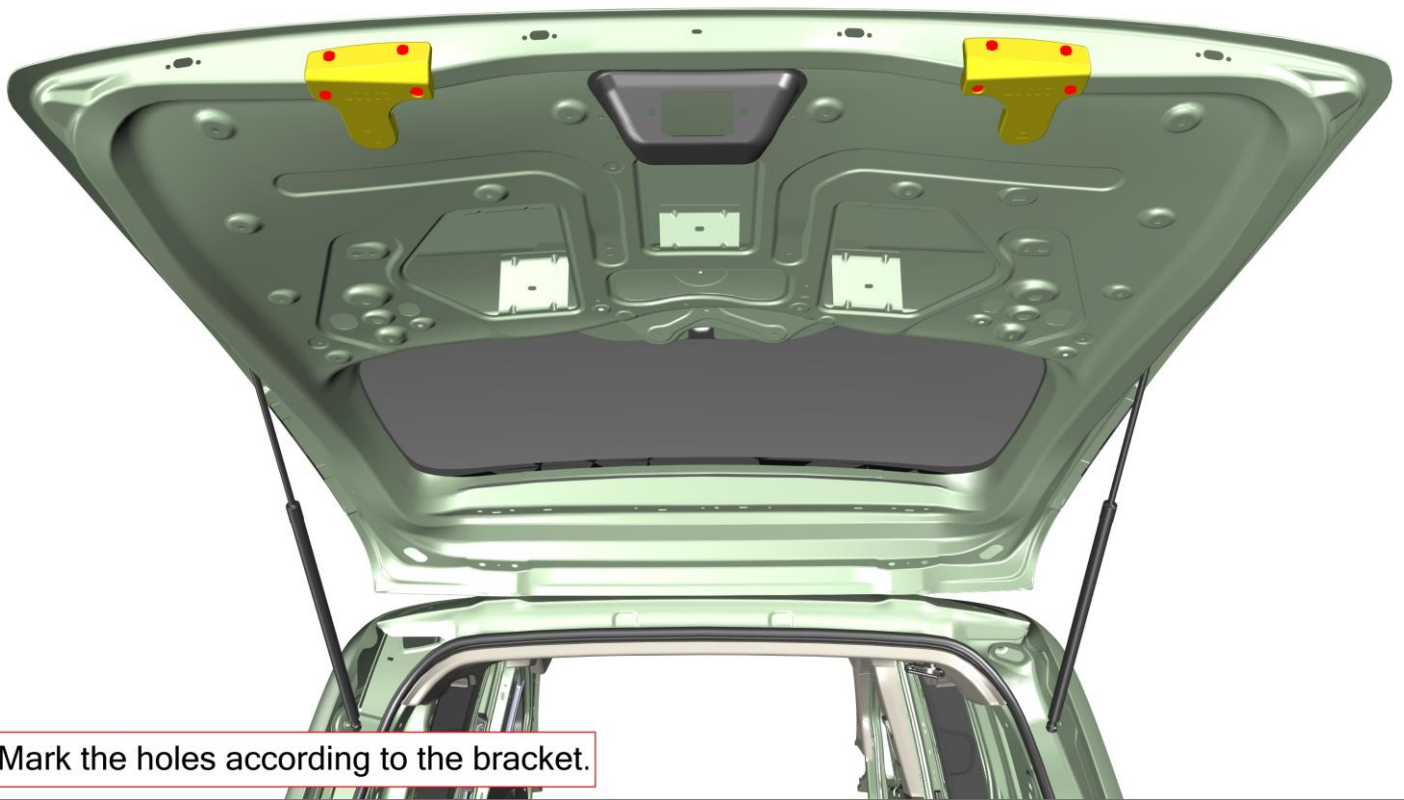

Rear bumper

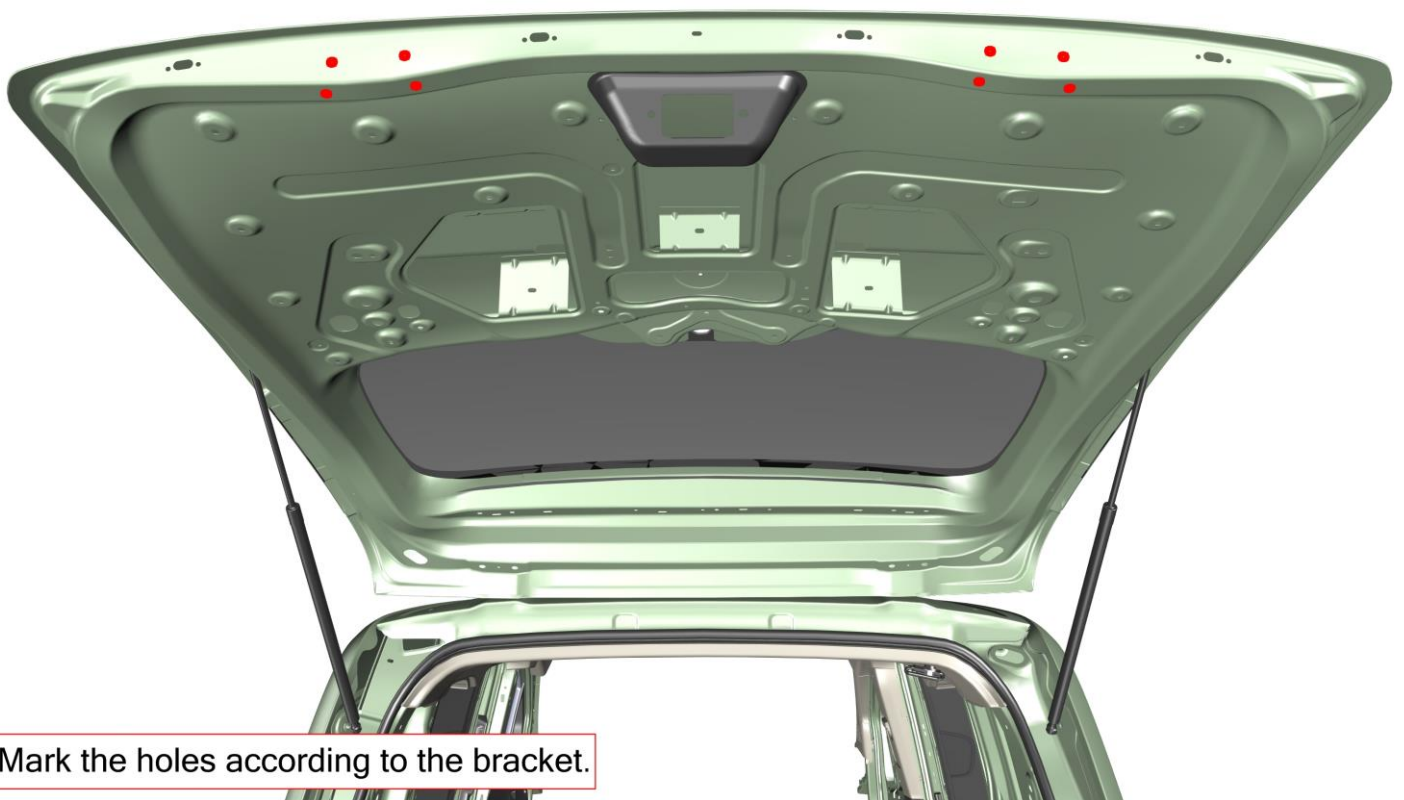

Rear bumper

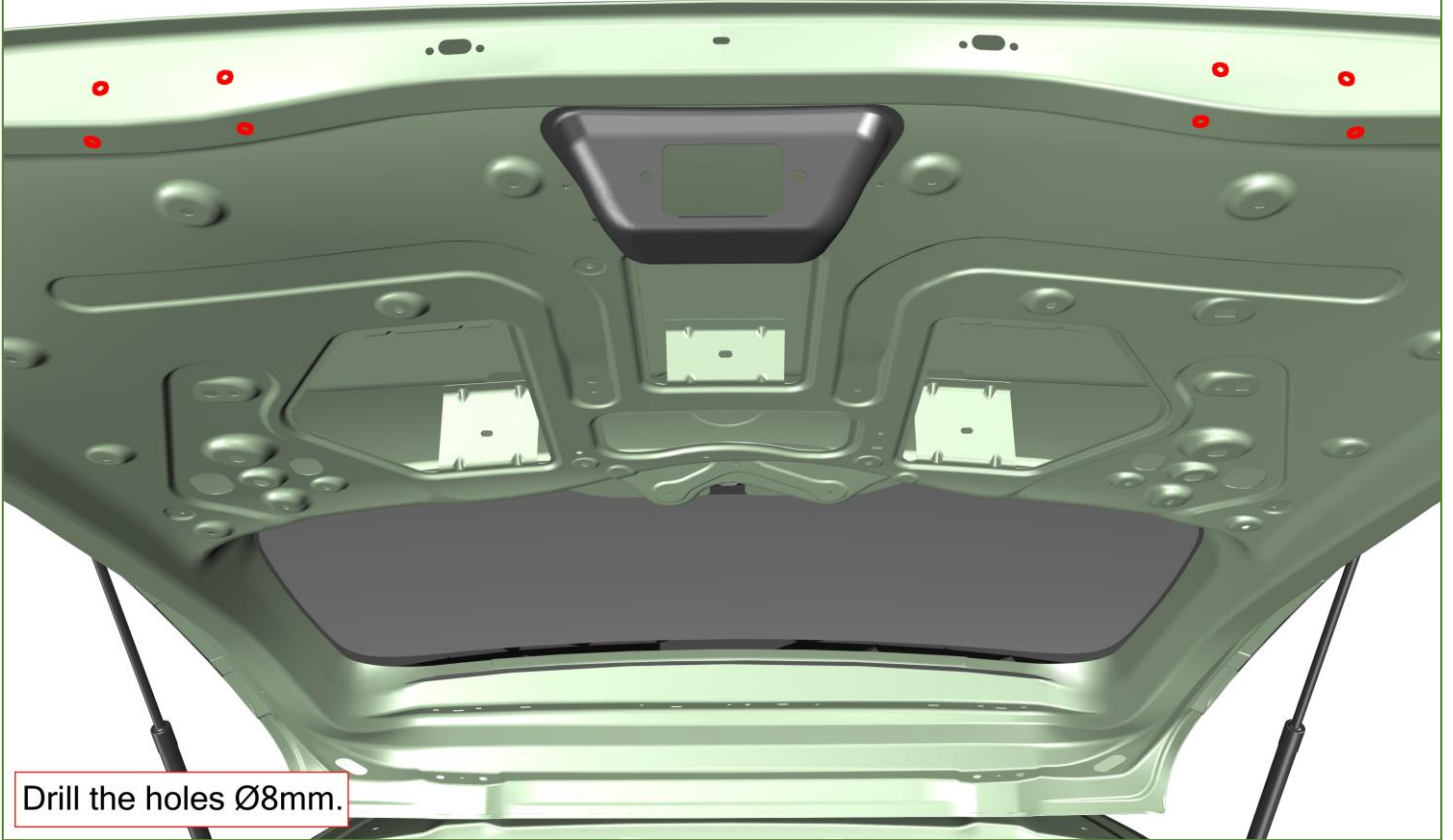

Rear bumper

This part can be bent upward so it's easier to position correctly.

19868

19870

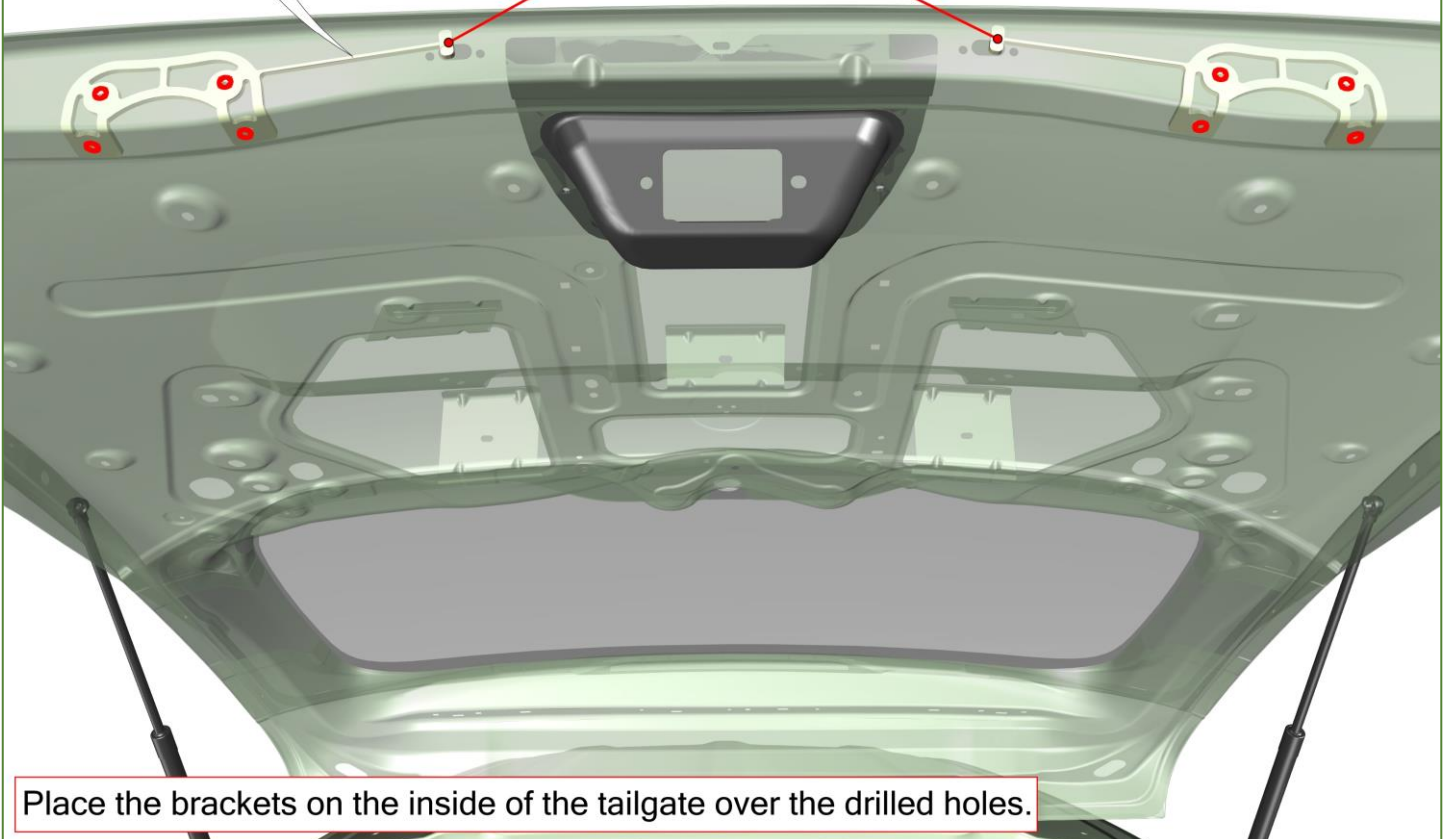



## Rear bumper

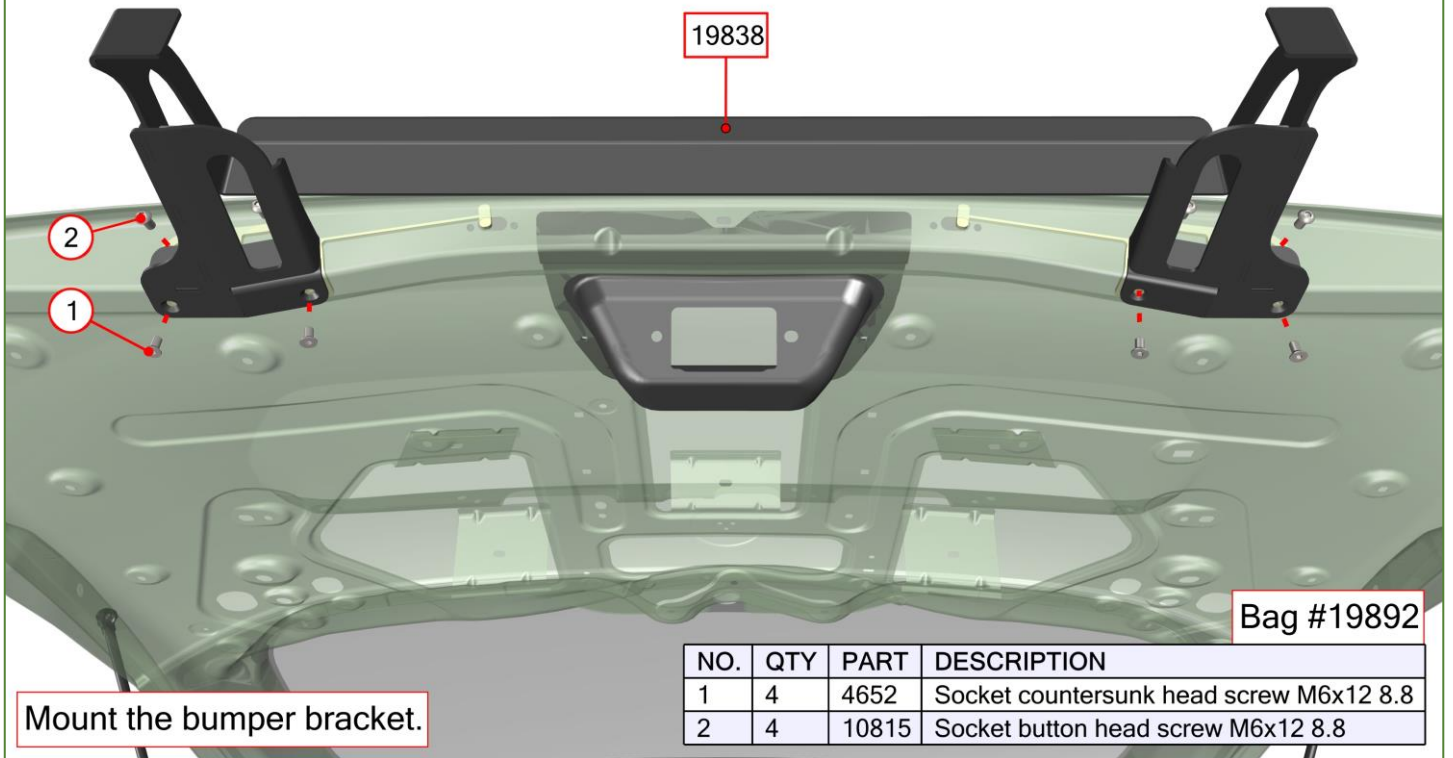

## Rear bumper

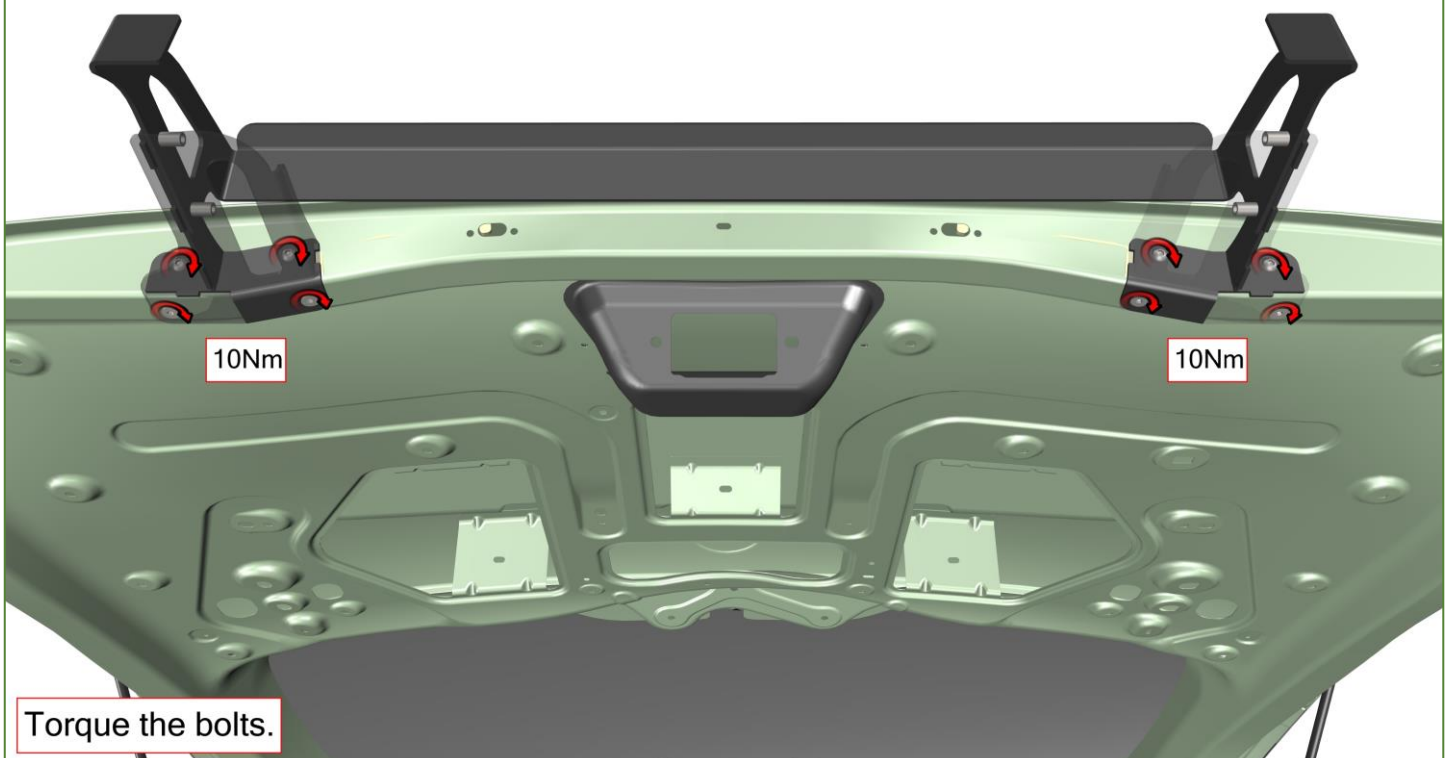

## Rear bumper

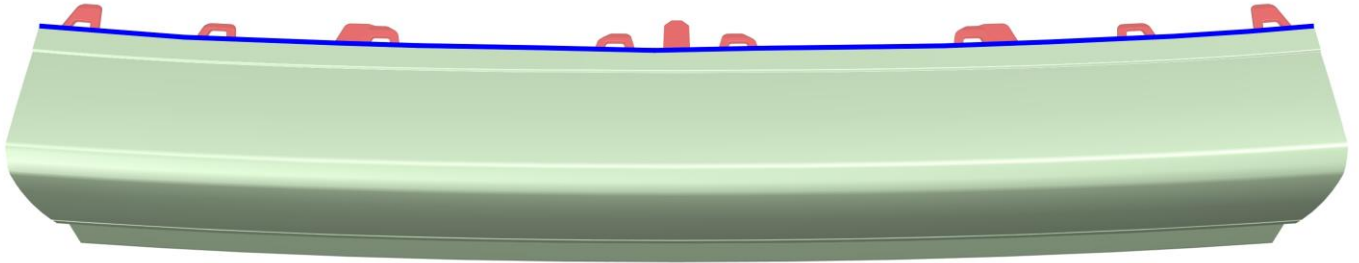

On the middle part of the bumper.  
Make the top inside edge smooth by removing any clip/bracket.

## Rear bumper

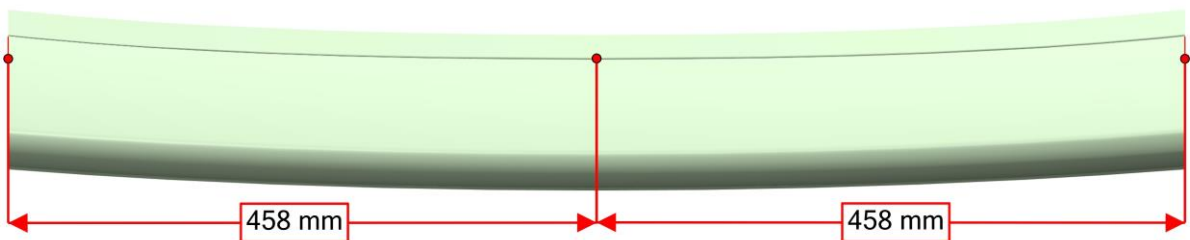

Modify the middle part of the bumper so the edges are perfectly straight. Use the measurement as reference. Check the width by placing the bumper in front of the ramp. The bumper should be at least equally wide or slightly wider than the ramp cover. Be sure not to cut off too much to prevent bad fitment to the side bumpers.

Rear bumper

Try testfitting the bumper caps.  
If it doesn't fit, this corner can  
be flattened for better fitment.



Cut off a bit from all 4 corners so the covers fit nicely. Check by placing the covers.

Rear bumper

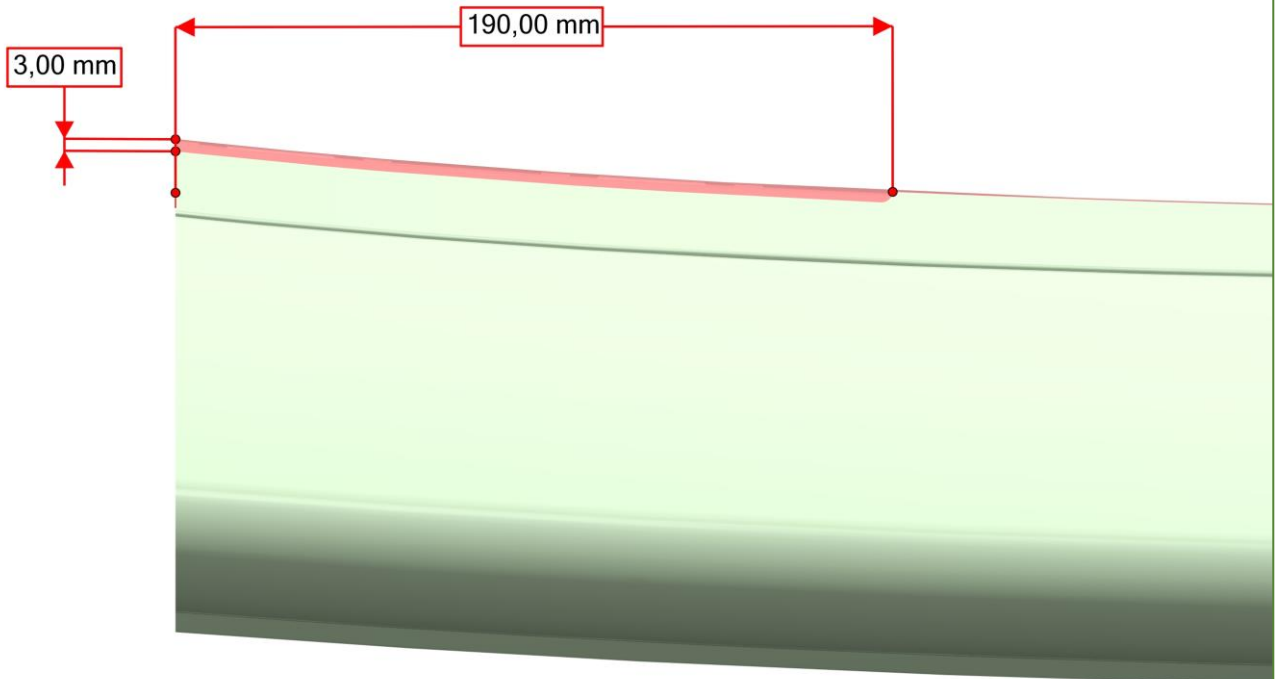

On the top of the bumper, modify the edge as shown, starting from the corners.  
This must be done for fitment on the rear bumper bracket. Do this left and right.



## Rear bumper



Close the ends of the middle bumper with the bumper covers. Make sure the bumper is at least as wide as the ramp cover. Check this by holding the bumper in front of the ramp.

## Rear bumper

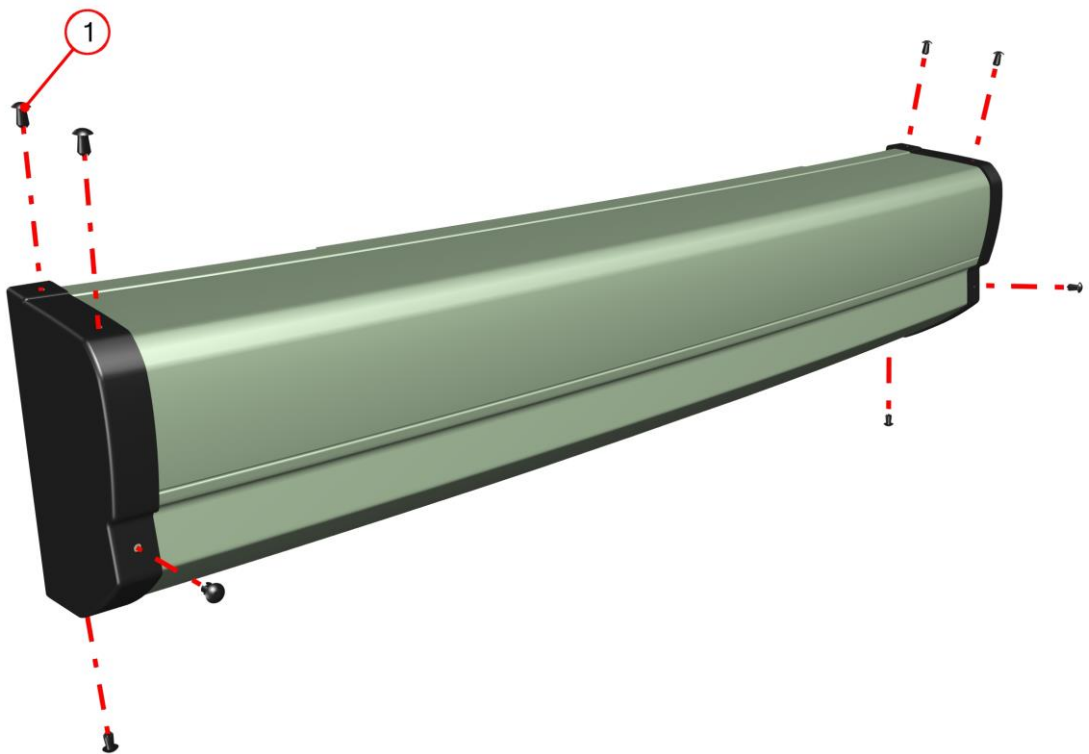

Drill the holes  $\varnothing 5\text{mm}$  on both sides as shown. Fasten the bumper covers with rivets.

Bag #19892

NO.	QTY	PART	DESCRIPTION
1	8	4832	Pop rivet PVC 5 mm

Rear bumper



Rear bumper

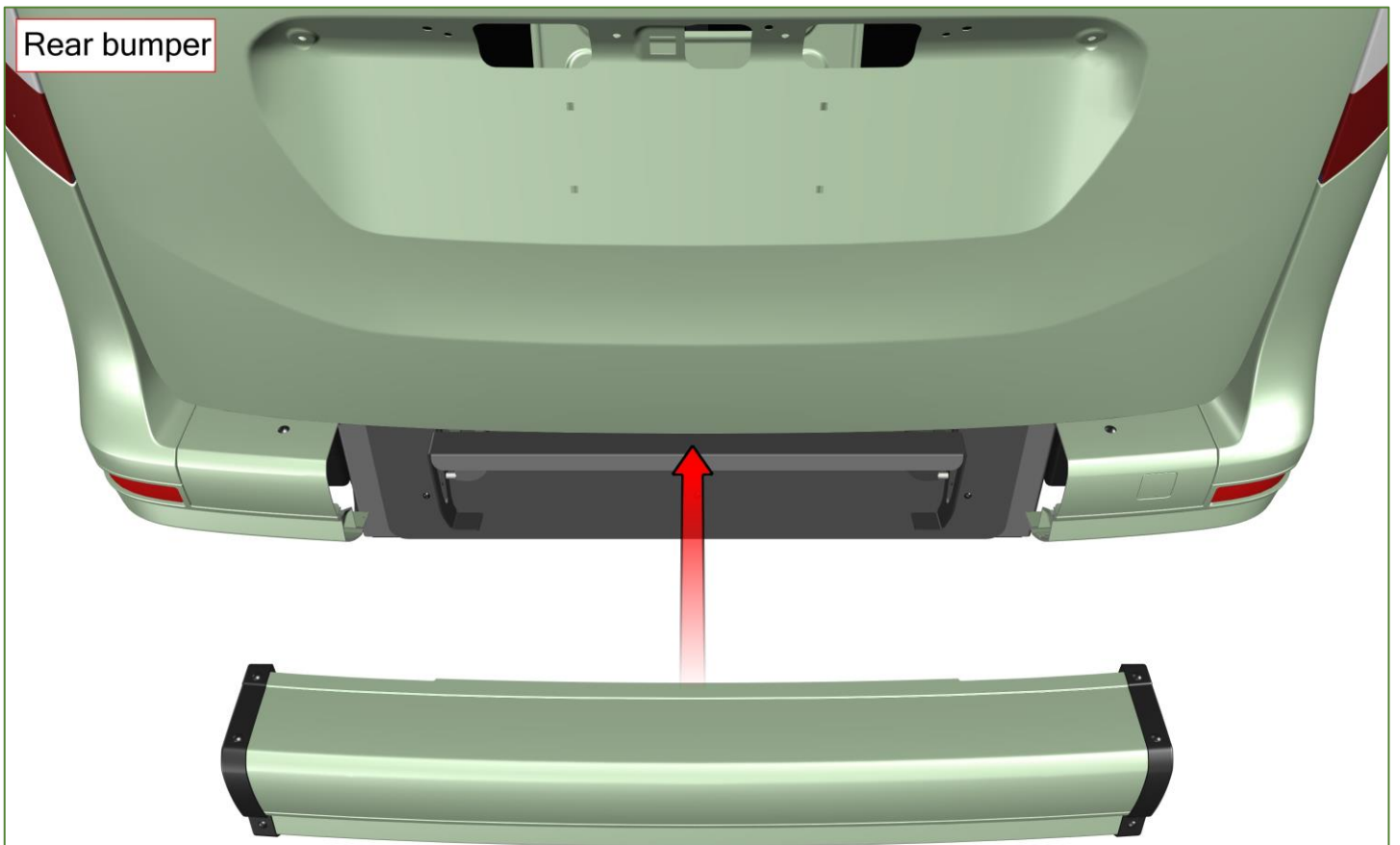

Position the middle bumper on the bracket.  
Plug in the parking sensors.

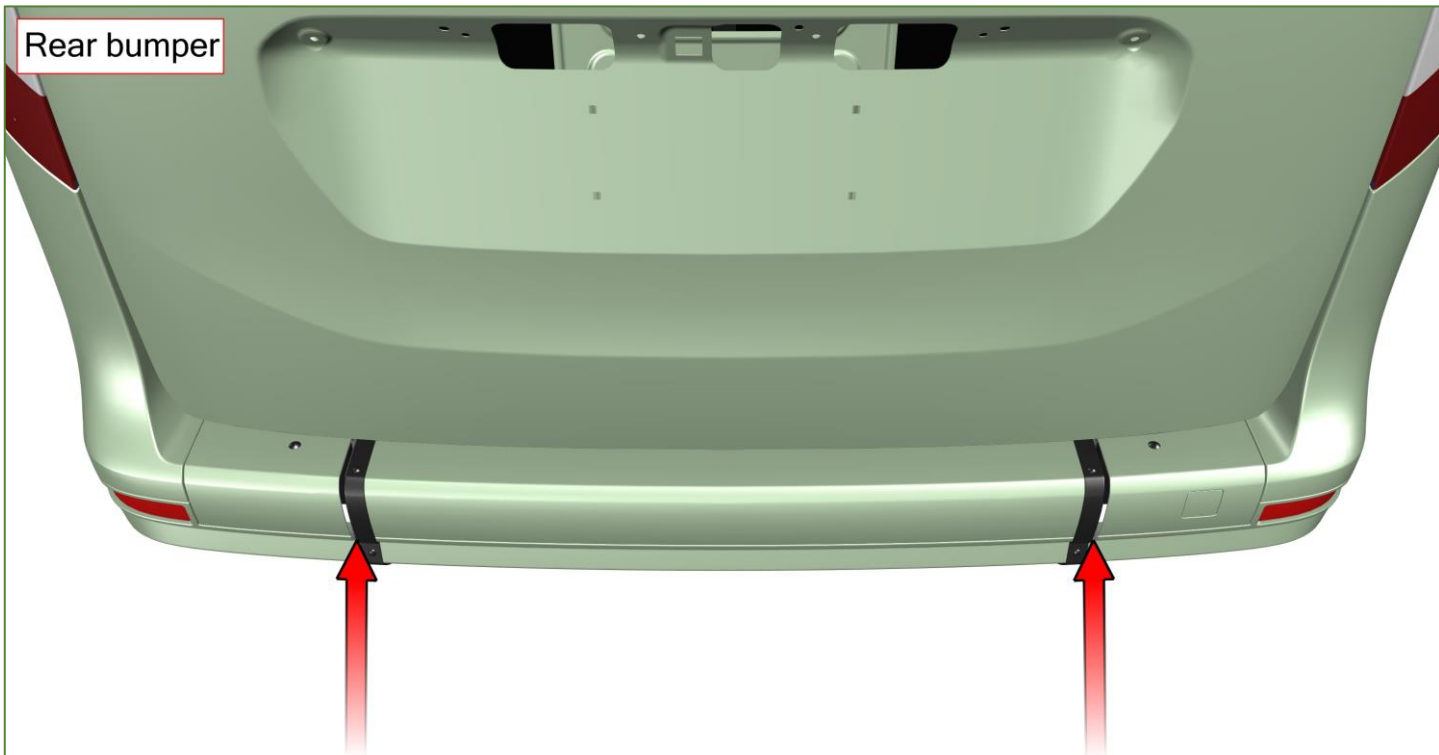

Center the middle bumper on the bracket.

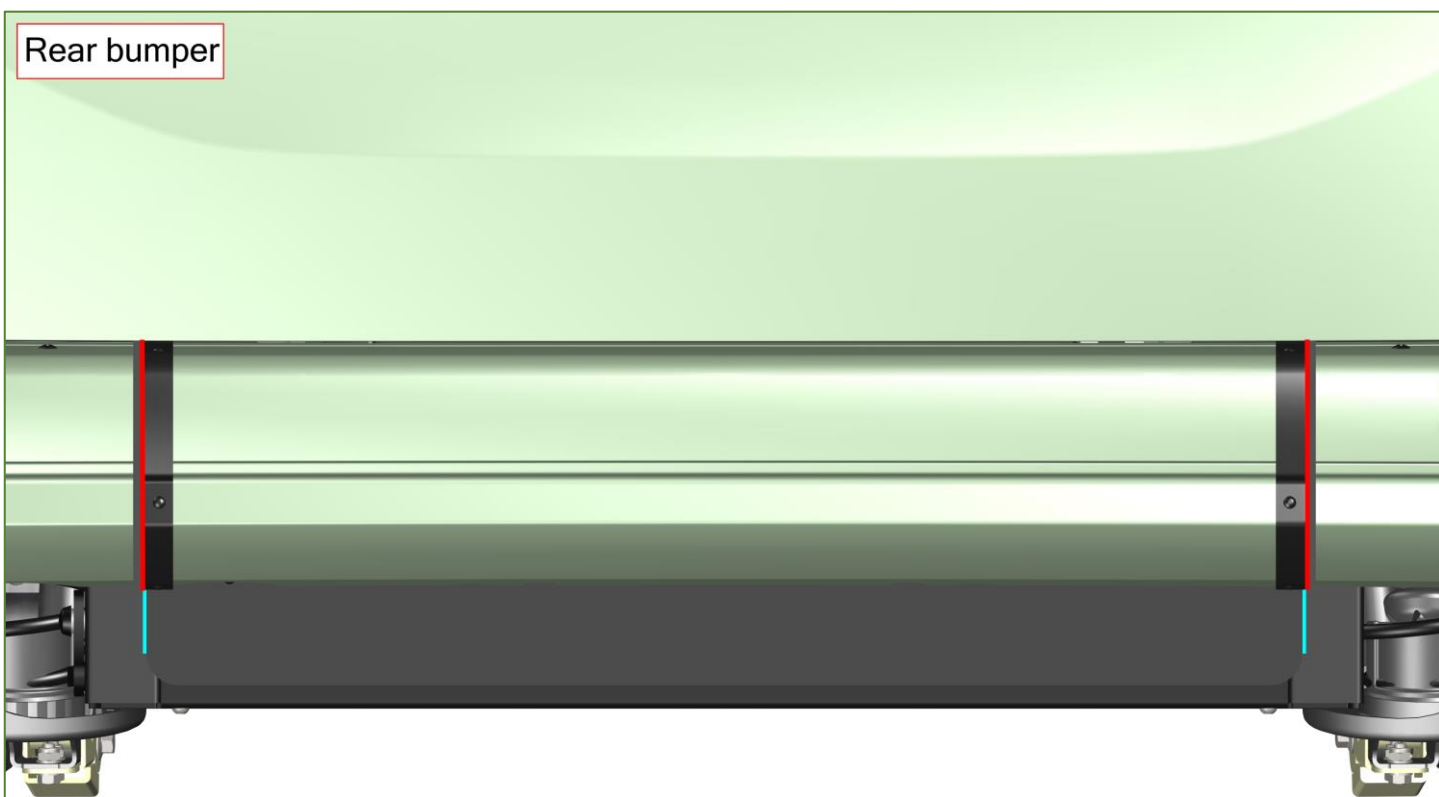

Use the marked edge (ramp cover) as reference to center the middle bumper.



Rear bumper



Drill and thread 2x M6 through the bumper and the middle bumper bracket. If the bumper and the bracket are not touching, use washers to adjust the fitment. Fasten with bolts.

Bag #19892

NO.	QTY	PART	DESCRIPTION
1	2	10387	Nylon button head screw M6x16 PA6

Rear bumper

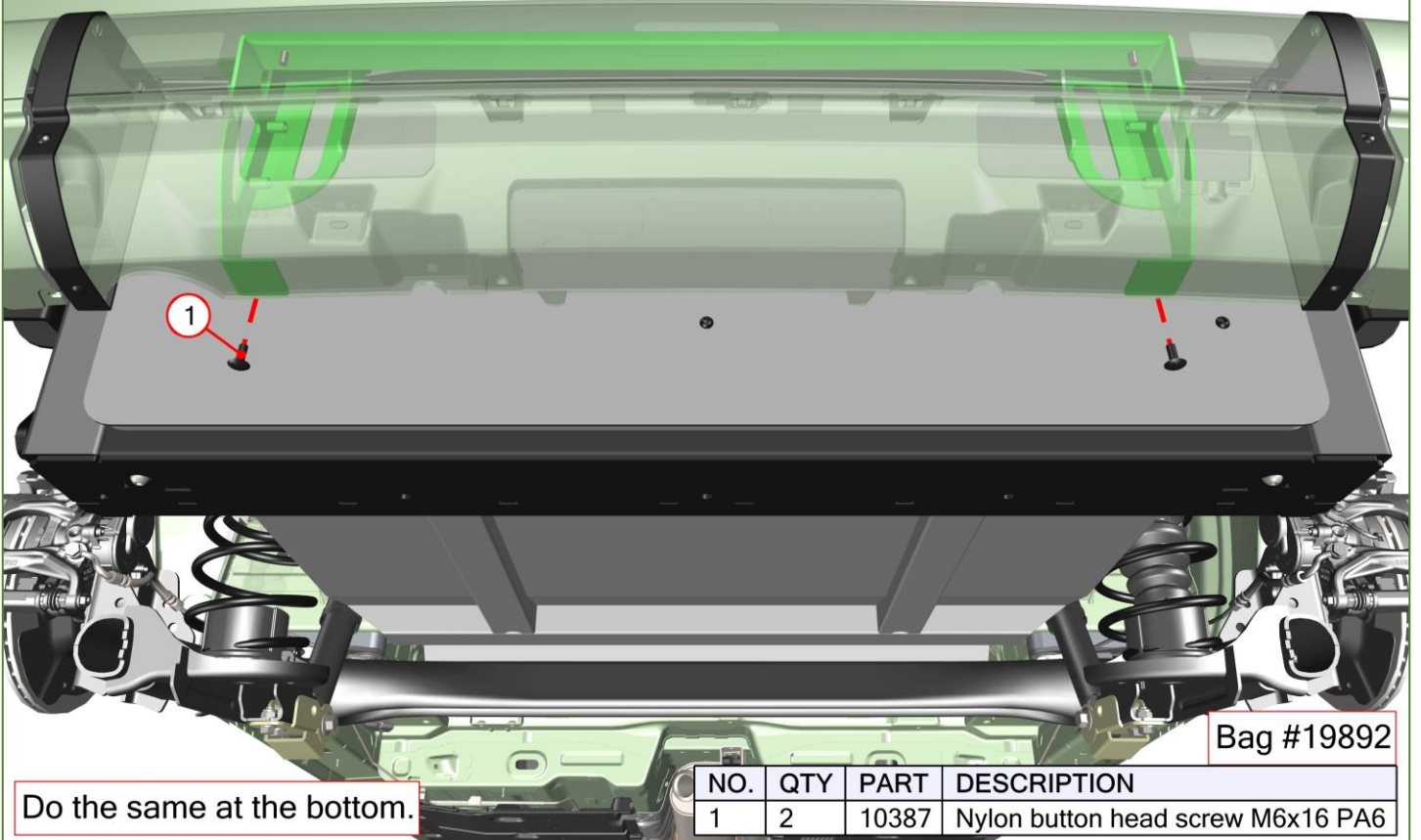

Do the same at the bottom.

Bag #19892

NO.	QTY	PART	DESCRIPTION
1	2	10387	Nylon button head screw M6x16 PA6

Rear bumper

5,00 mm

A technical diagram showing the rear bumper assembly. Two black bumper covers are being positioned on either side of a central metal bar. A red double-headed arrow indicates a 5.00 mm gap between the inner edges of the two covers. The car's body is shown in a light green color, and a red taillight is visible on the left side.

Place the outer bumper covers. Be sure the covers are 5 mm apart and parallel towards each other. If not, modify the outer bumpers or bumper covers where necessary to achieve this.

Rear bumper

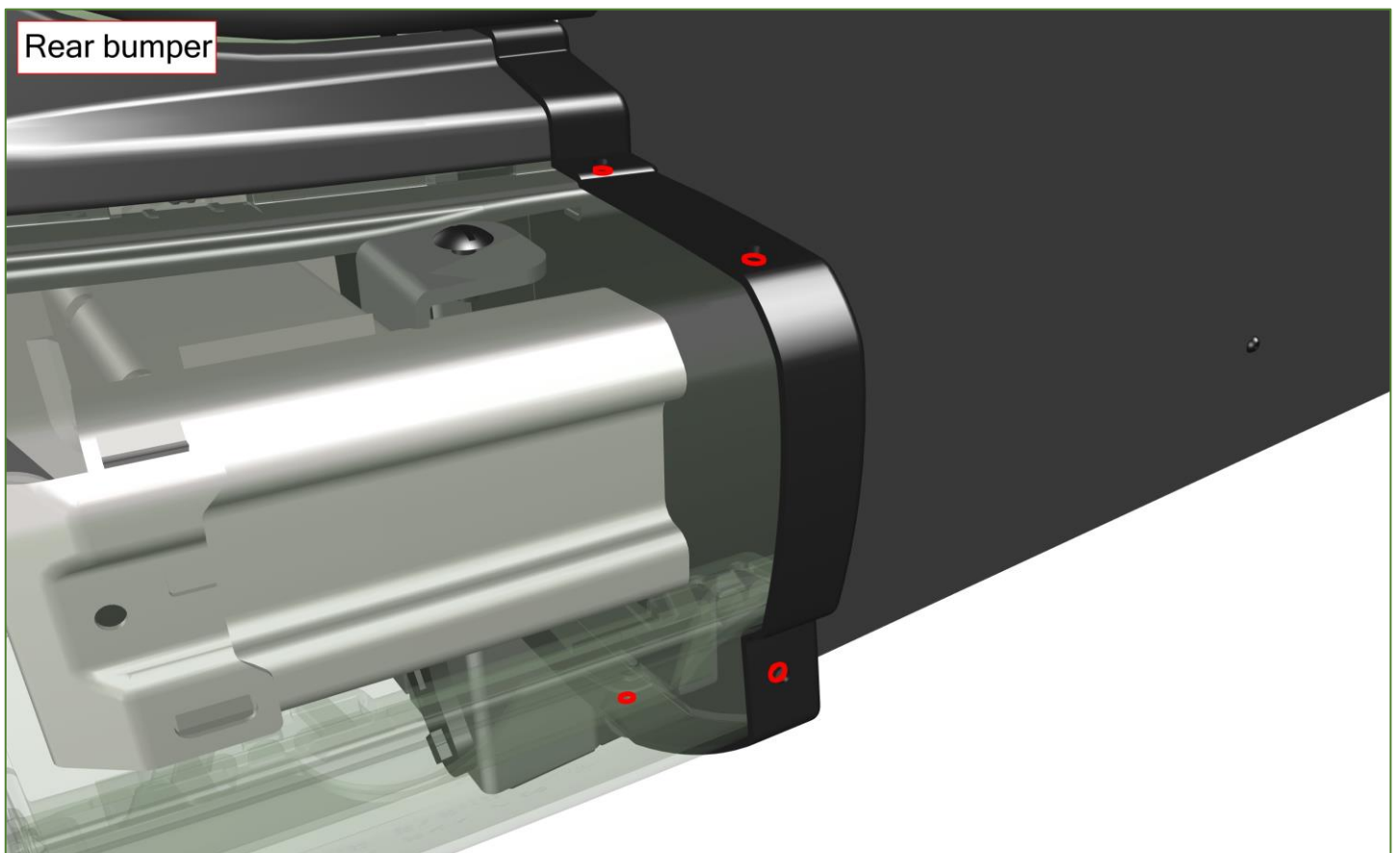

Place the bumper covers on the outer bumpers. Drill the holes through the outer bumpers  $\text{\O}5$  mm. Do this on both sides.

Rear bumper

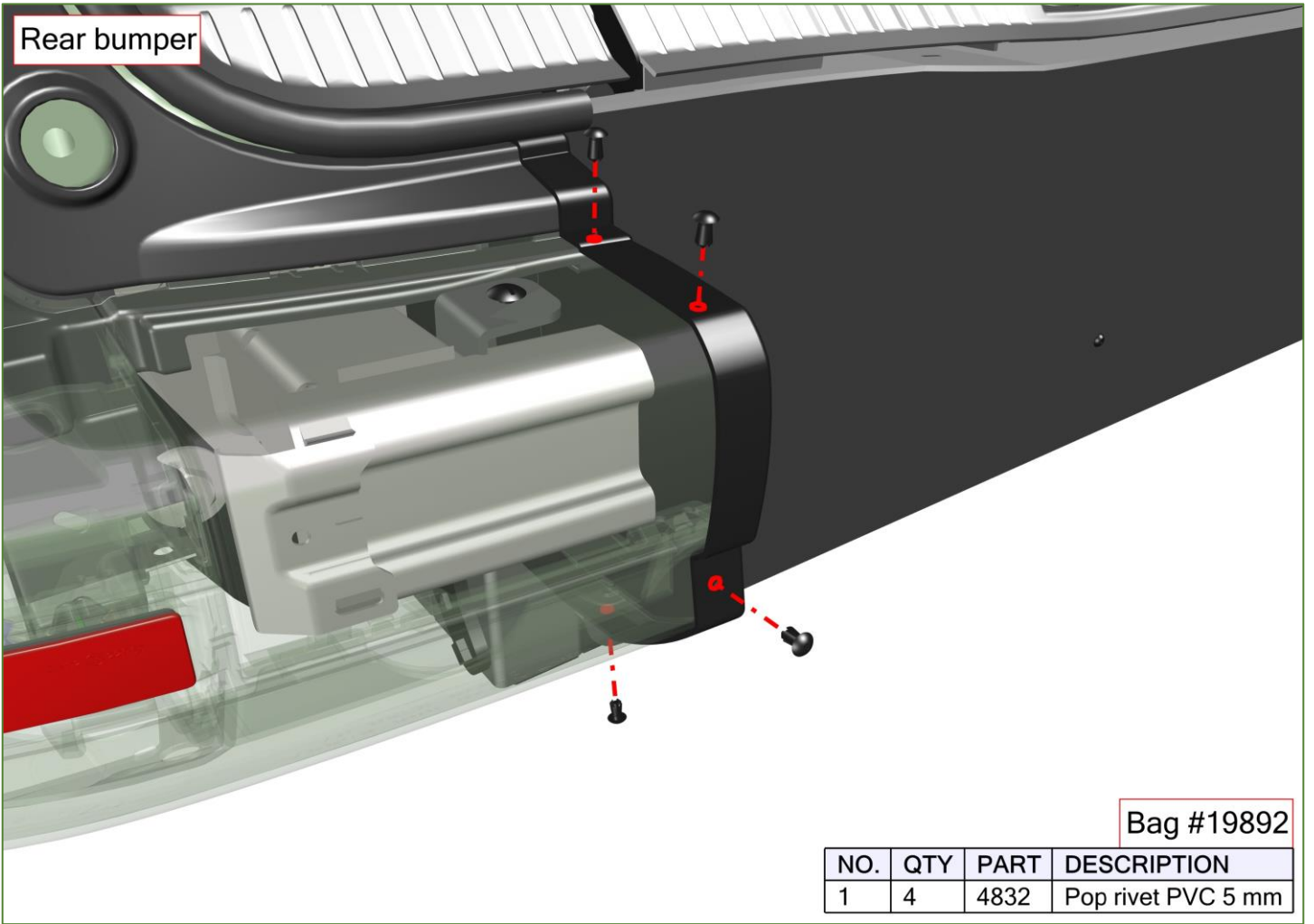

Bag #19892

NO.	QTY	PART	DESCRIPTION
1	4	4832	Pop rivet PVC 5 mm

Emergency exit

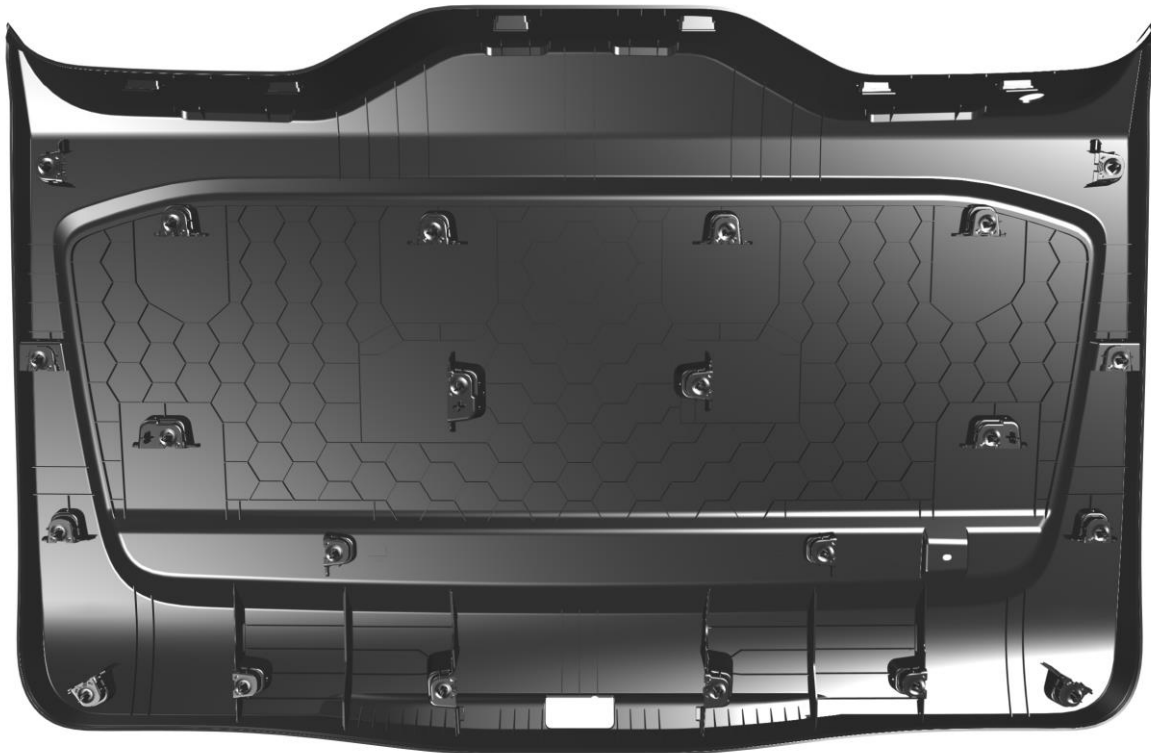

Get the tailgate cover.



Emergency exit

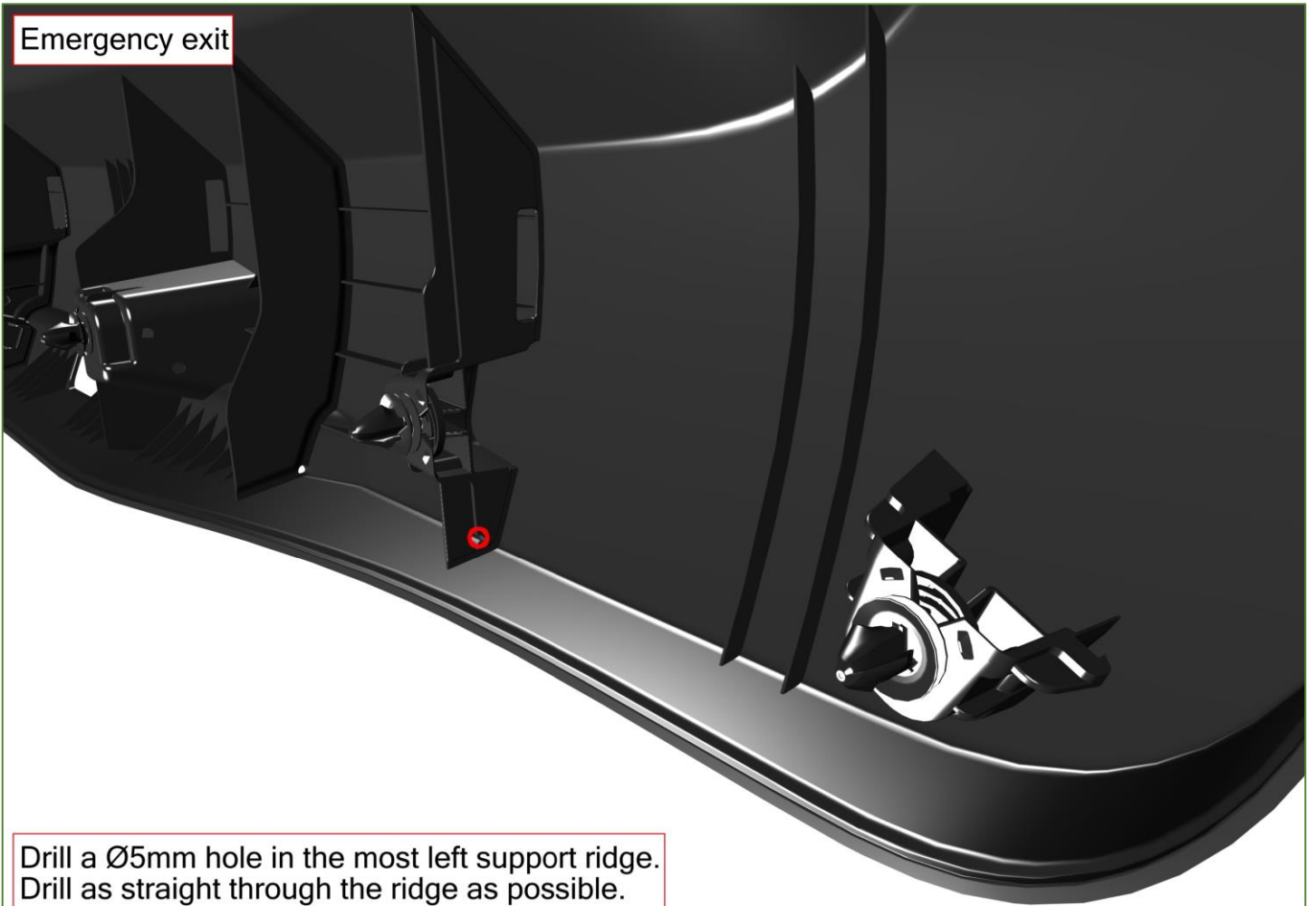

Drill a Ø5mm hole in the most left support ridge.  
Drill as straight through the ridge as possible.

Emergency exit

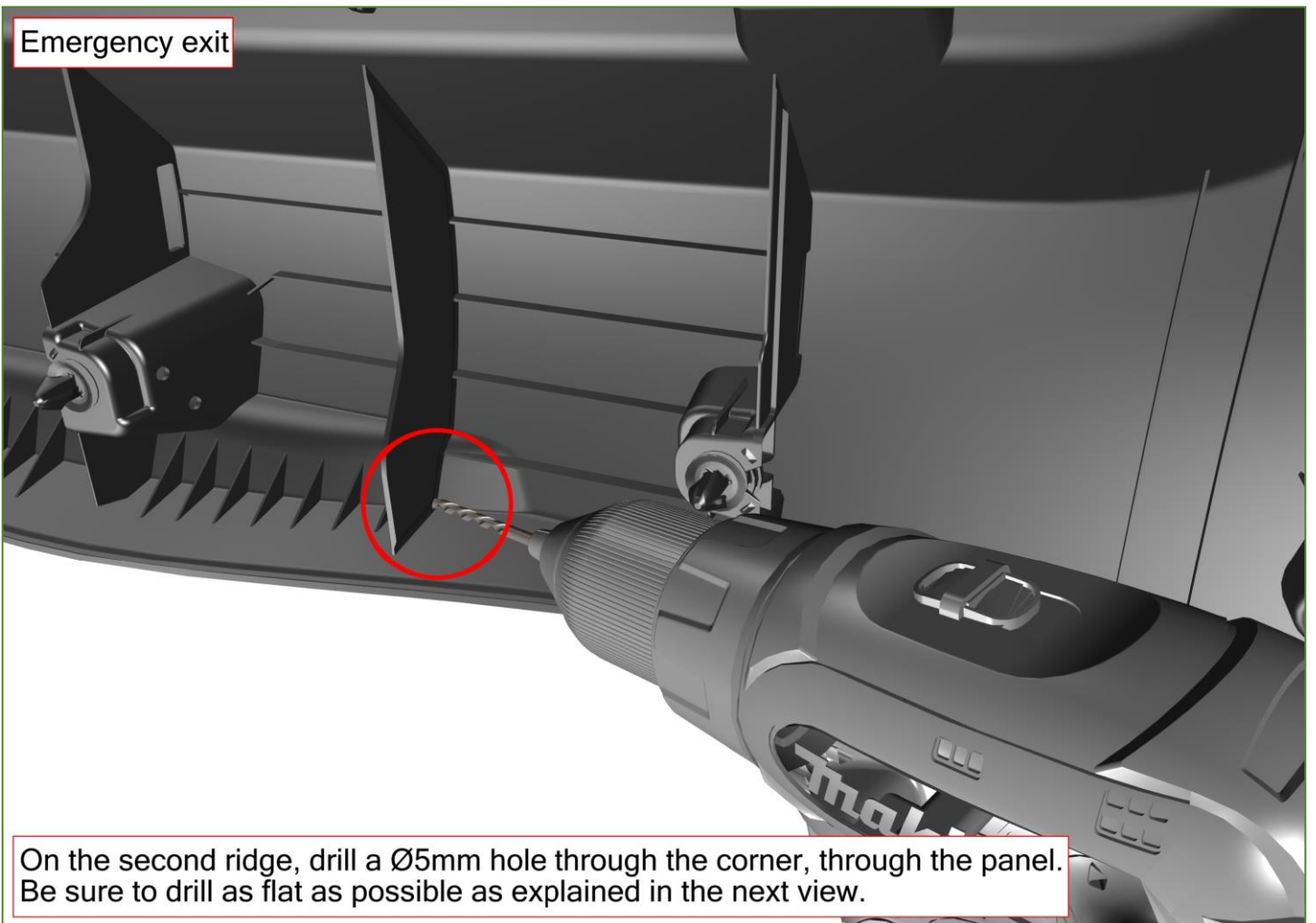

On the second ridge, drill a Ø5mm hole through the corner, through the panel.  
Be sure to drill as flat as possible as explained in the next view.

Emergency exit

Be carefull not to damage the outside of the cover with the rotating bits on the drill.

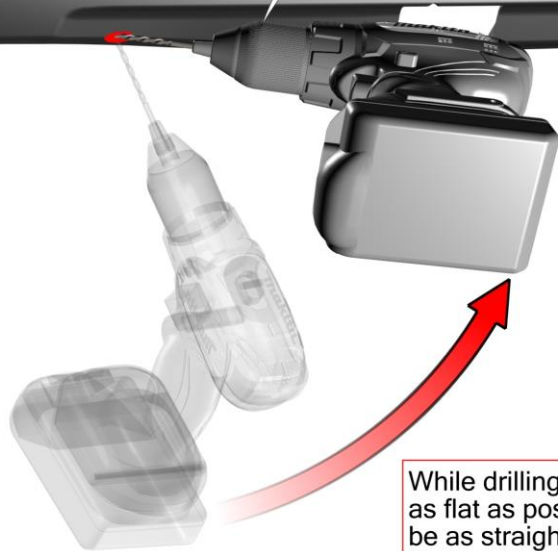

While drilling, rotate the drill up to be as flat as possible. The hole must be as straight as possible.

Drill through the other side of the hole.

Emergency exit

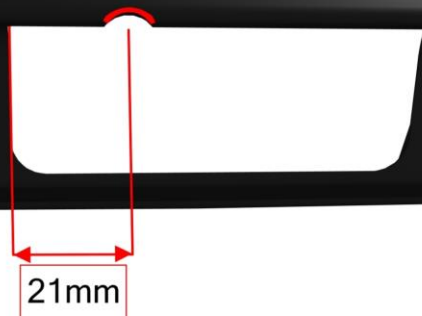

Use a  $\text{Ø}10\text{mm}$  drill to carve a slight extra bit of space in the opening for the tailgate lock. Drill where marked.

## Emergency exit

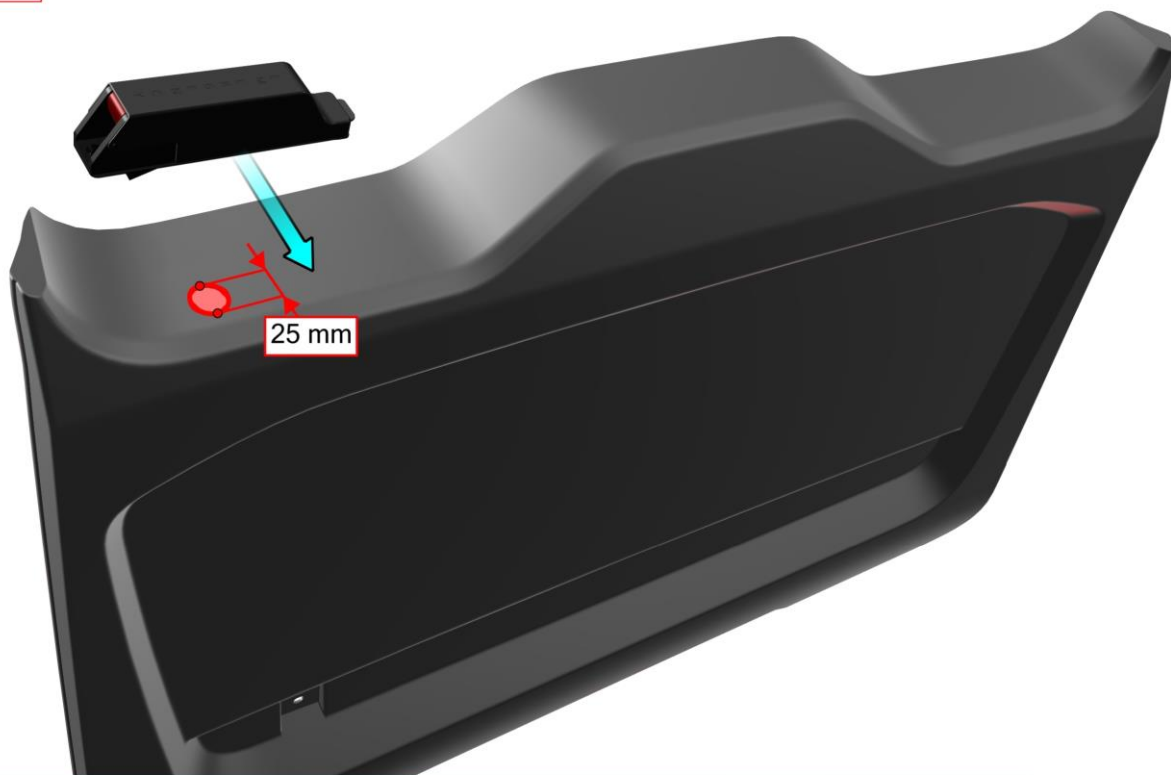

Use the latch to determine its position.  
Place the latch on the right side of the tailgate cover.  
Make sure it will be mounted on the flat surface, not on the radius.  
Mark and drill a  $\varnothing 25\text{mm}$  hole where the cable mounts will extend through the hole.

## Emergency exit

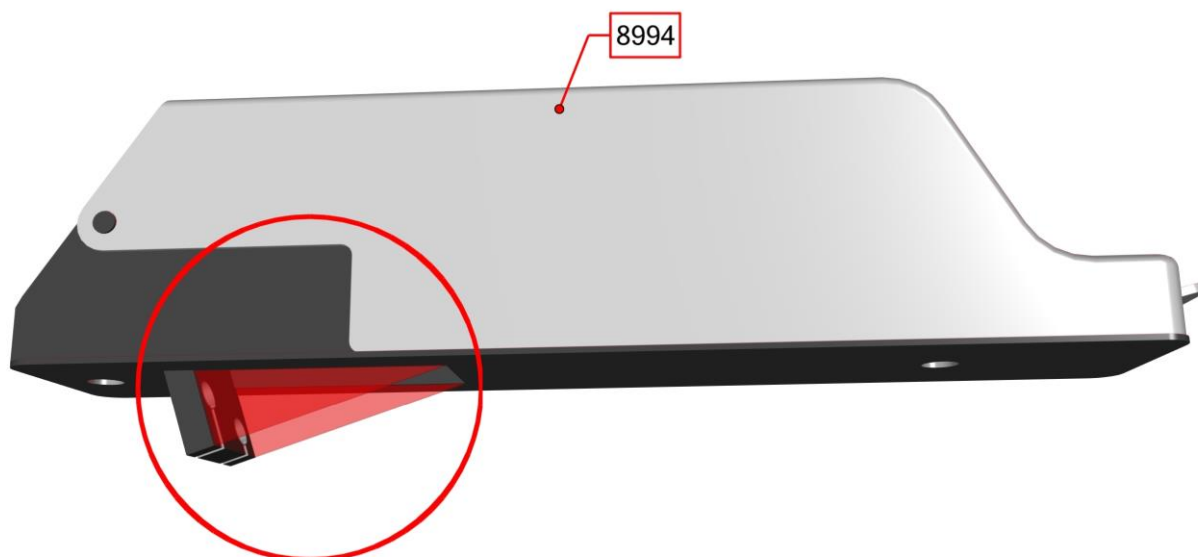

Remove the sides of the bottom black housing as shown.



Emergency exit

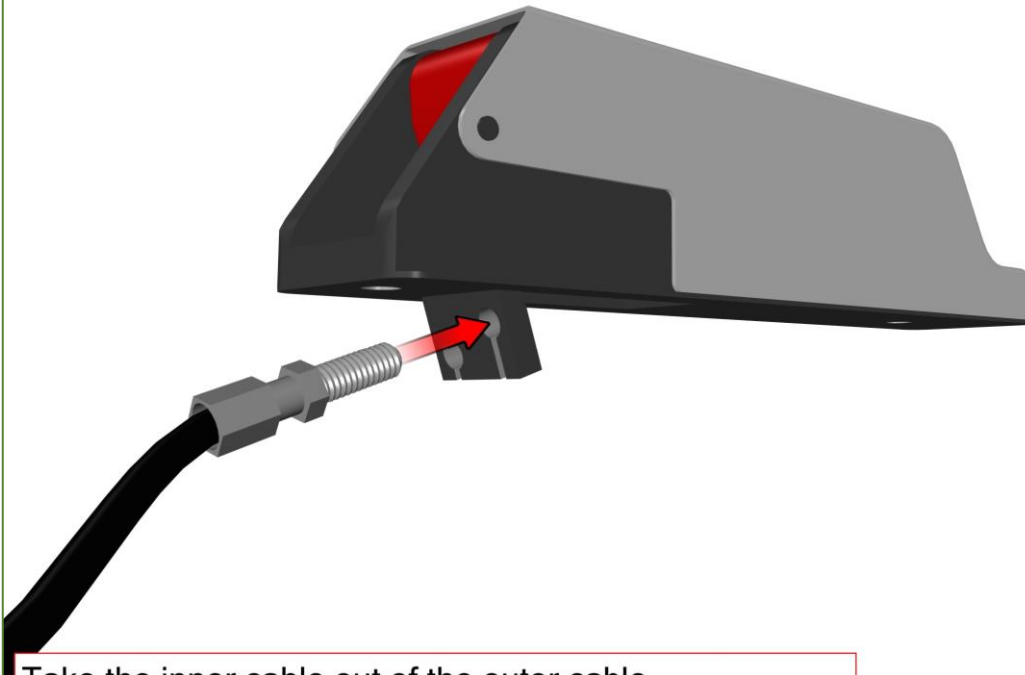

Take the inner cable out of the outer cable.  
Screw the cable adjuster all the way into the upper hole.

Emergency exit

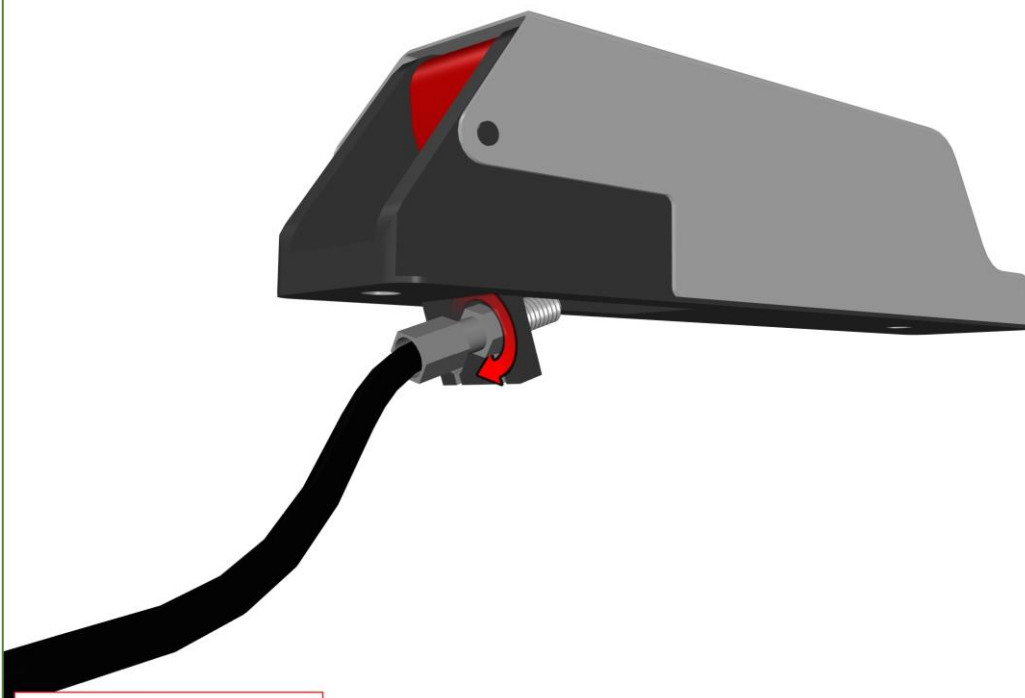

Secure with the nut.

## Emergency exit

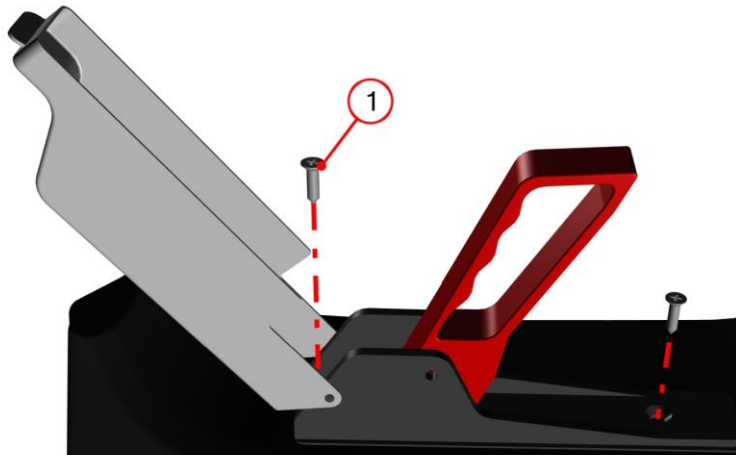

Bag #20843

Install the latch on the cover with screws.

NO.	QTY.	PART	DESCRIPTION
1	2	7657	Parker 4,8x19 verzonkenkop - A2

## Emergency exit

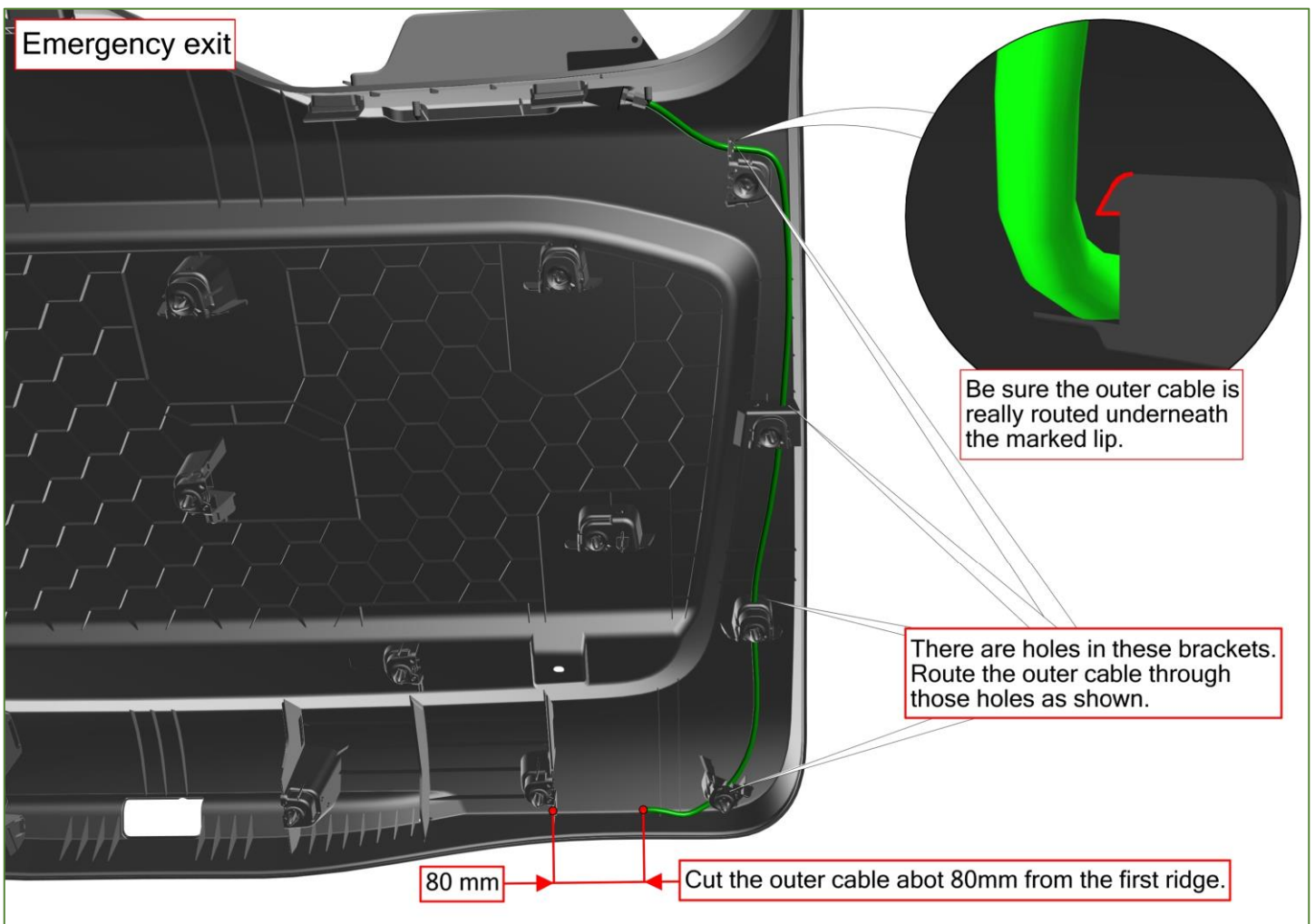

Emergency exit

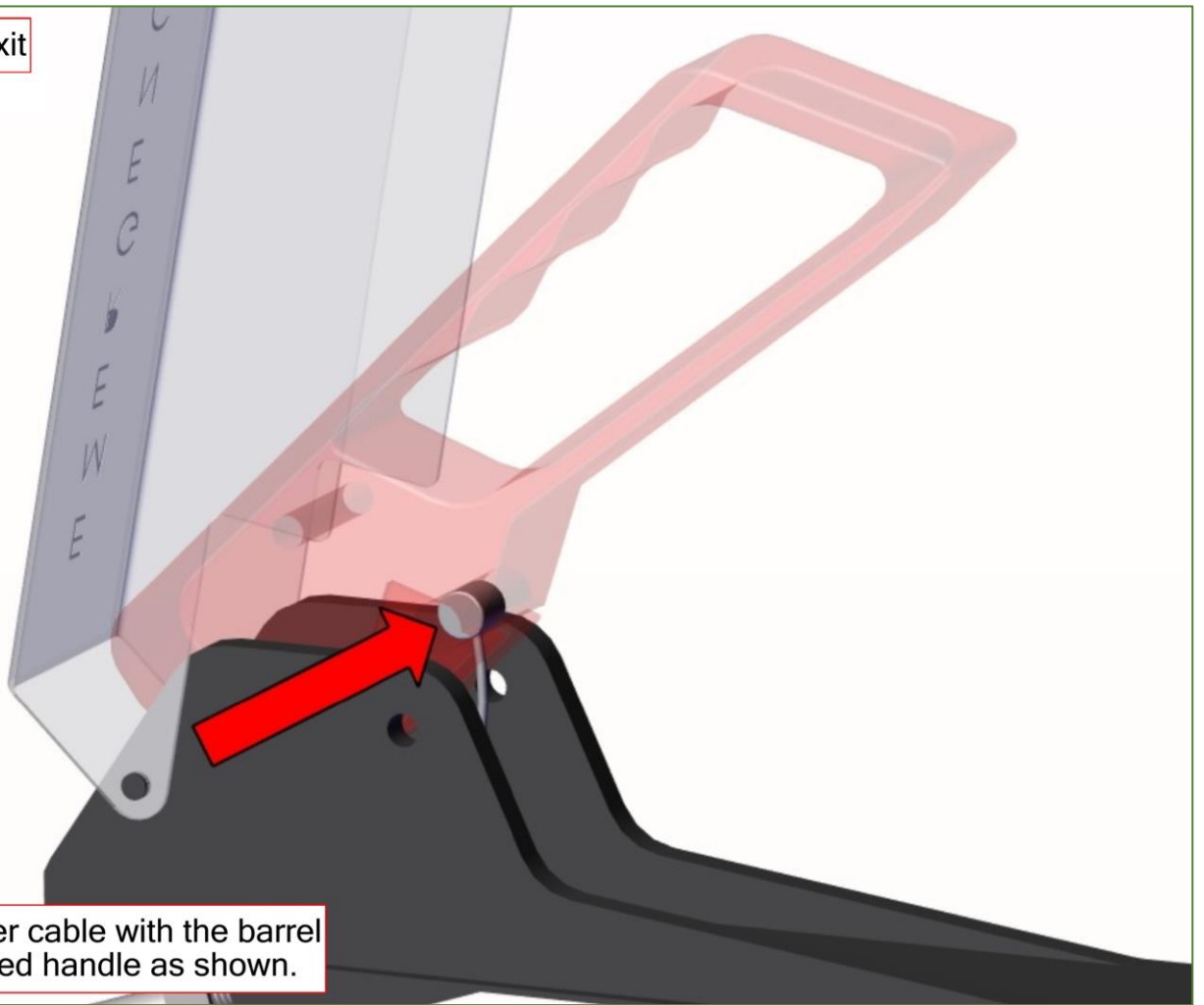

Insert the inner cable with the barrel nipple in the red handle as shown.

Emergency exit

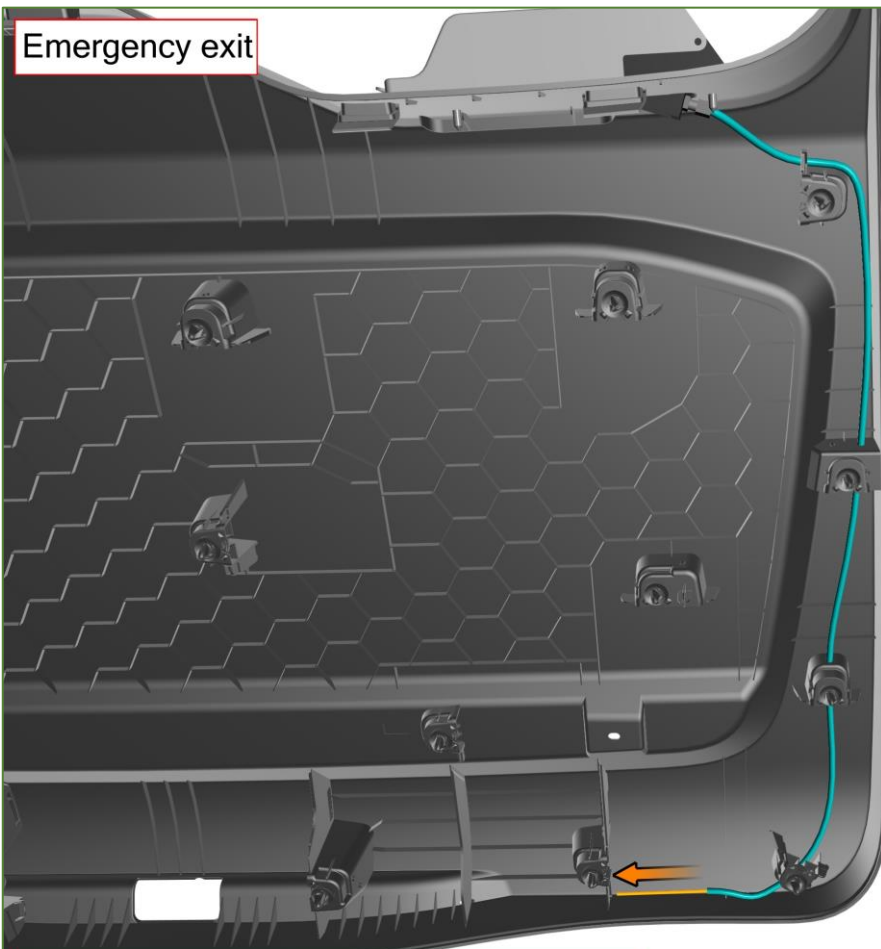

Insert the inner cable into the outer cable.



Emergency exit

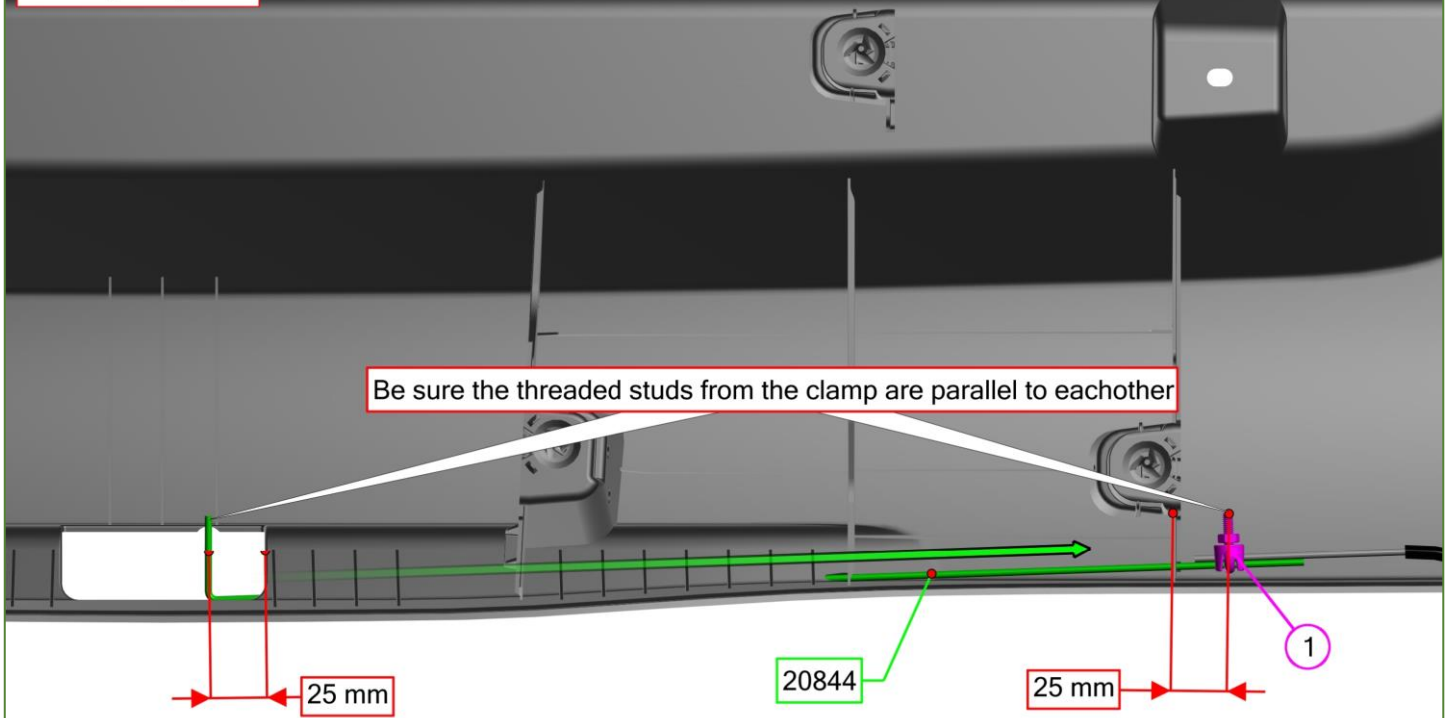

Insert the rod through the drilled holes as shown.  
Use a clamp to fix the rod to the inner cable.  
Make sure rod 20844 can slide without friction.

Bag #20483

NO.	QTY.	PART	DESCRIPTION
1	1	8835	Steel wire clamp 3mm

Emergency exit



Reinstall the tailgate panel.

## Emergency exit

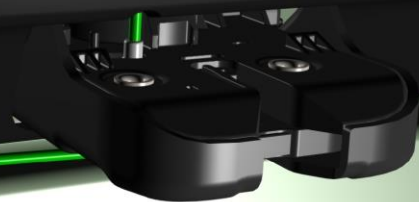

Insert the rod through the plastic latch in the tailgate lock.

## Emergency exit



Apply the screw nipple to the end of the rod to secure the emergency exit system. After completing this step, check if the system works correctly. Also check if the door indicator light functions properly during a test drive. If not release the tension of the cable.

### Tailgate cover protection

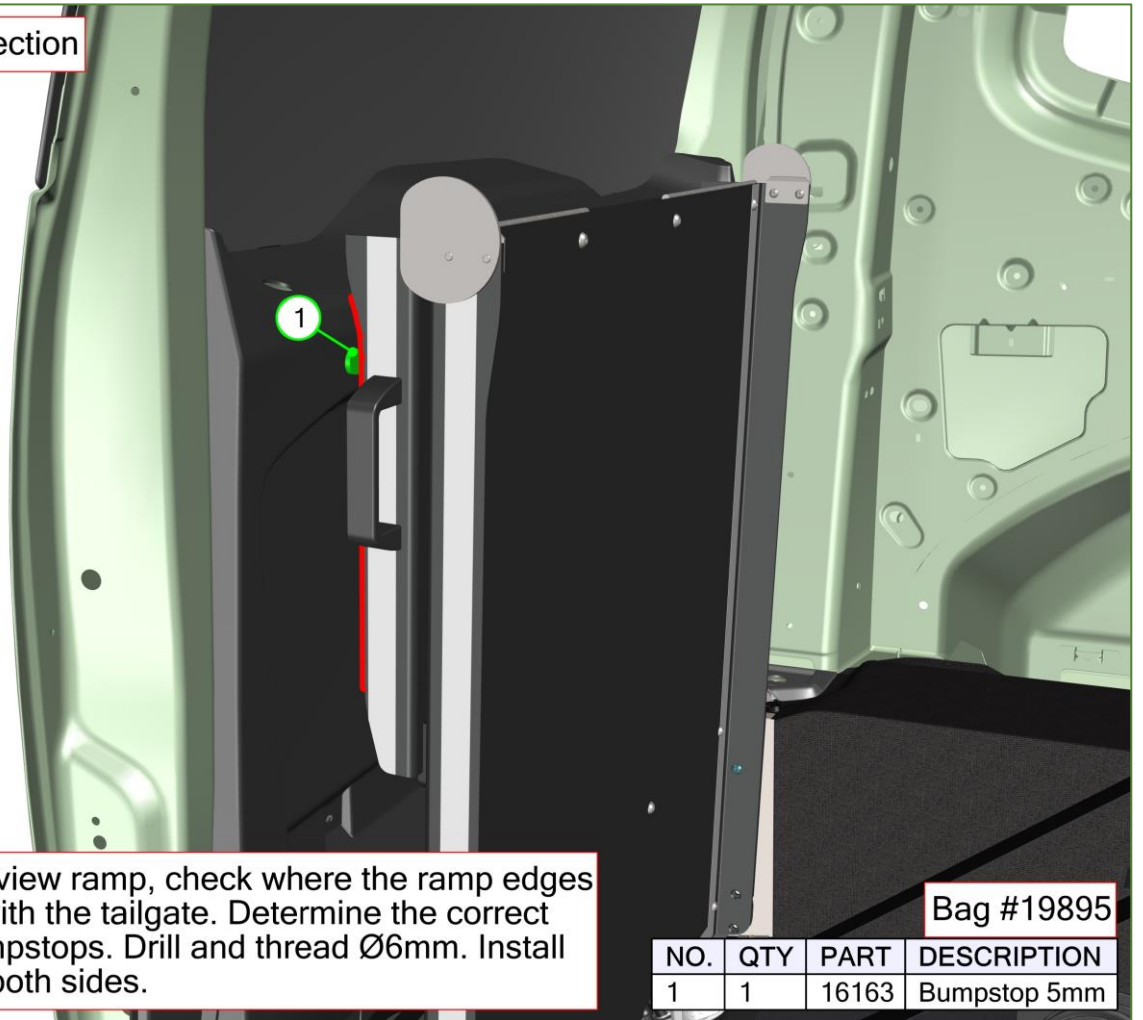

In case of the clearview ramp, check where the ramp edges will make contact with the tailgate. Determine the correct position for the bumpstops. Drill and thread  $\varnothing 6\text{mm}$ . Install the bumpstops on both sides.

Bag #19895

NO.	QTY	PART	DESCRIPTION
1	1	16163	Bumpstop 5mm

### Rear retractors

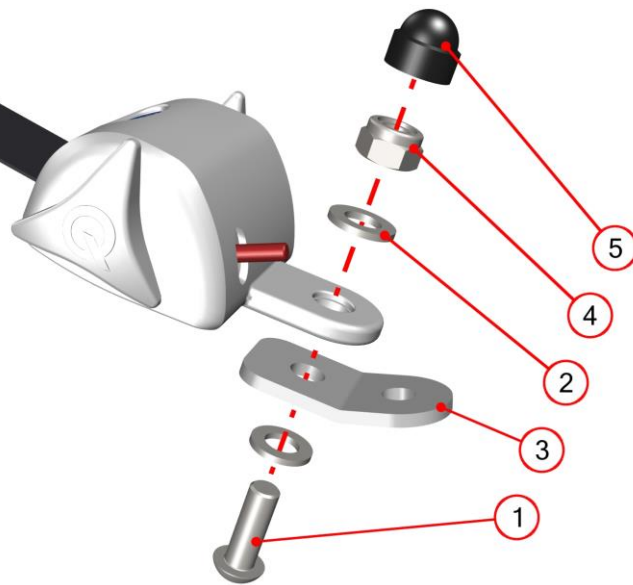

Bag #20999

NO.	QTY	PART	DESCRIPTION
1	1	21613	Socket button head screw M12x35 10.9
2	2	294	Washer M12 8.8
3	1	20997	Angled bracket
4	1	18139	Torque nut M12 10.9
5	1	21011	Bolt cap M12

Install the Triplock mounting parts on the rear retractor. Left and right are installed the same.



Rear retractors

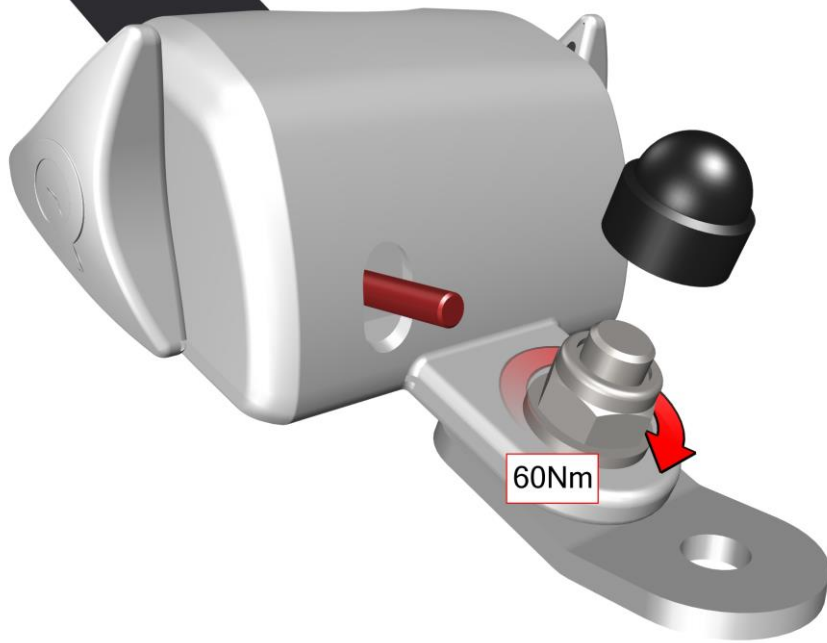

Rear retractors

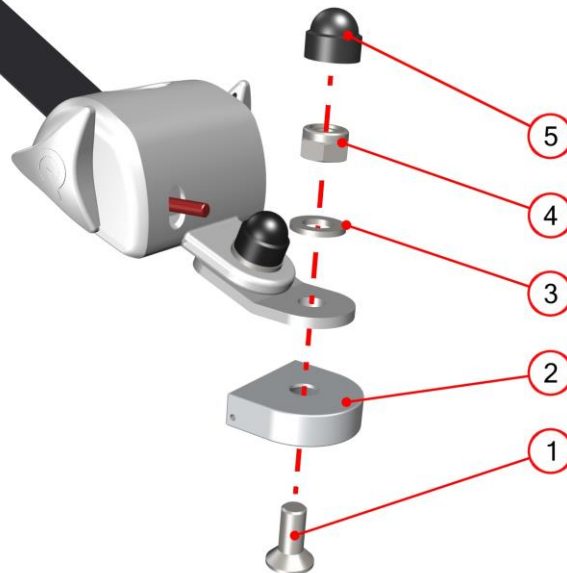

Bag #20999

NO.	QTY	PART	DESCRIPTION
1	1	21006	Socket countersunk head screw M12x30 10.9
2	1	20996	Triplock floor part
3	1	294	Washer M12 8.8
4	1	18139	Torque nut M12 10.9
5	1	21011	Bolt cap M12

Install the Triplock mounting parts on the rear retractor. Left and right are installed the same.

Rear retractors

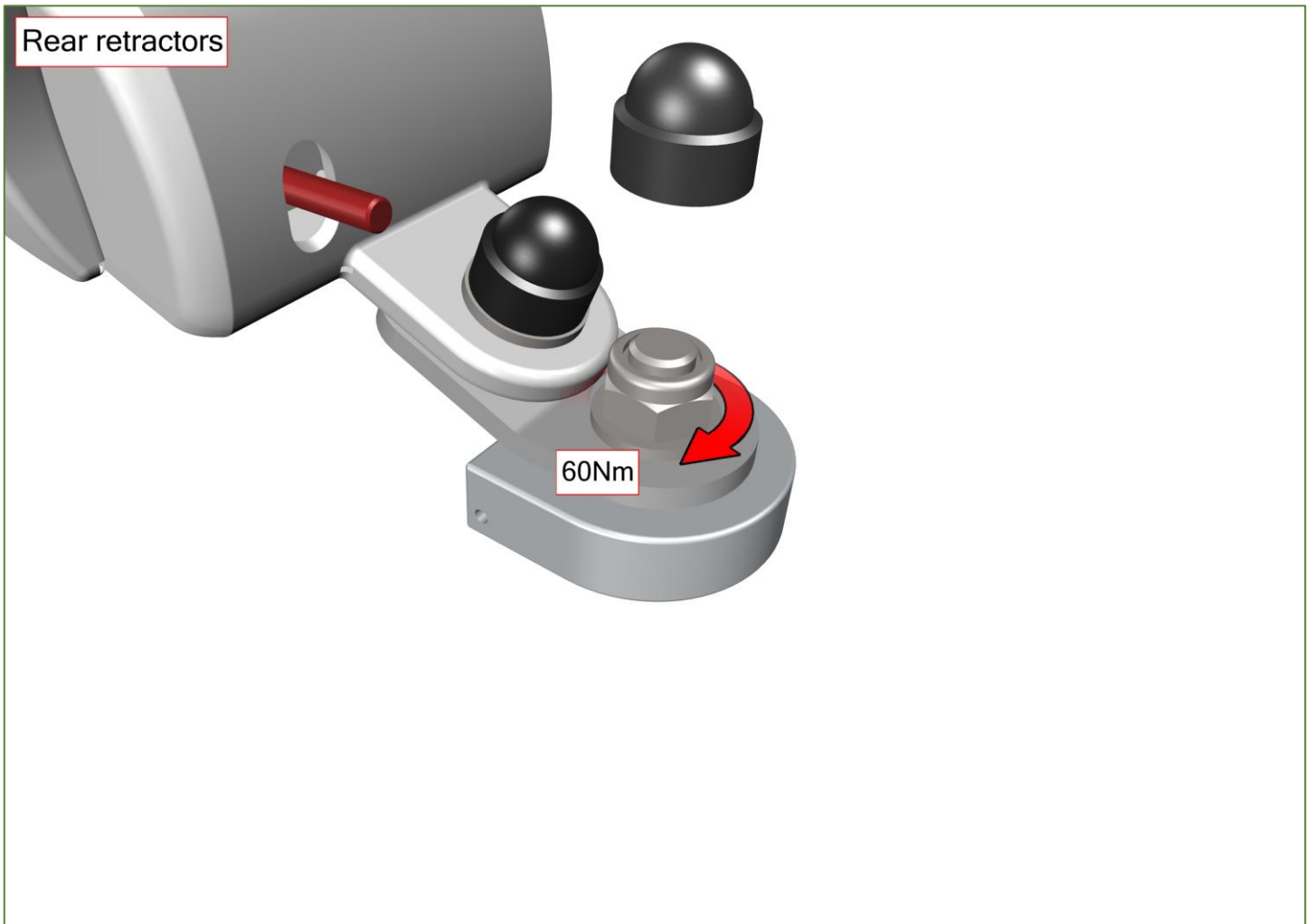

Rear retractors

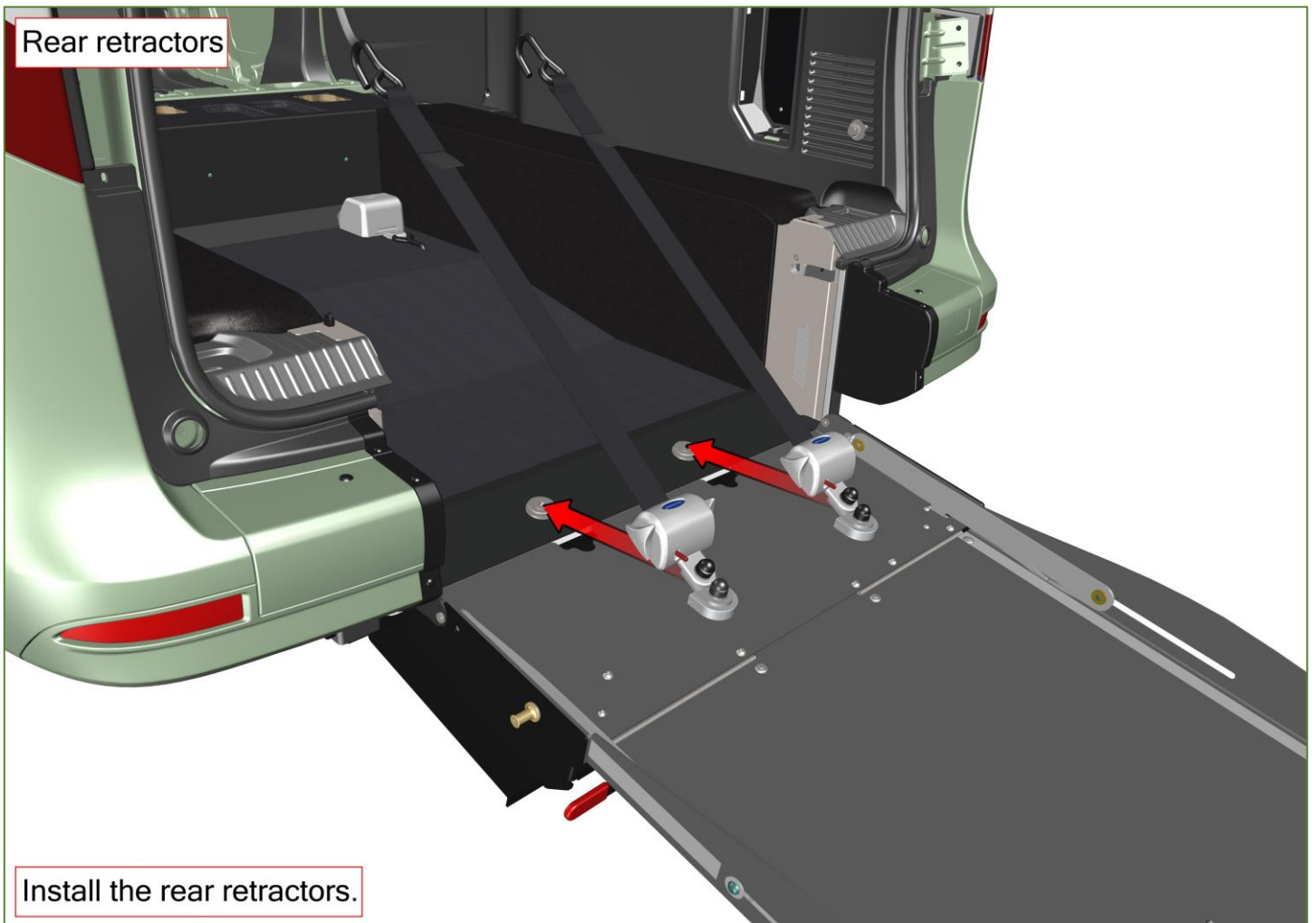

Install the rear retractors.

End of conversion

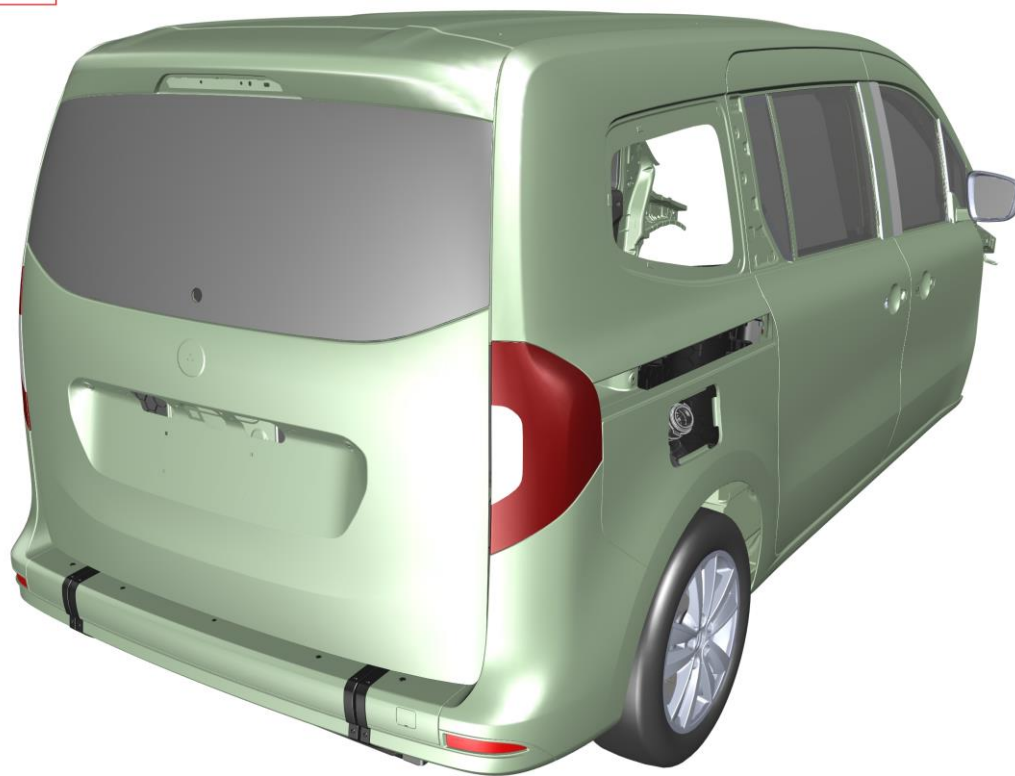

Vaccuum the interior.



# Tightening torques

	Zinc coated steel		Stainless steel	
	8.8	10.9	70	80
M4	3 Nm	4 Nm	2,5 Nm	3,5 Nm
M5	6 Nm	8 Nm	5 Nm	7 Nm
M6	10 Nm	14 Nm	8 Nm	11 Nm
M8	26 Nm	37 Nm	21 Nm	28 Nm
M10	54 Nm	75 Nm	44 Nm	58 Nm
M12	85 Nm	120 Nm	71 Nm	88 Nm
M12x1,5	89 Nm	125 Nm		
M14x1,5	150 Nm	205 Nm		
M16x1,5	220 Nm	310 Nm		
<b>UNF</b>				
		<b>Grade 5</b>		
7/16 CTSK Triplock		60 Nm		
7/16 seat belt		35 Nm		
<b>Blind rivet nut</b>				
	<b>Steel</b>	<b>Aluminium</b>	<b>Stainless</b>	
M5	5	4	4,5	
M6	9	6	7,5	
M8	22	18	20	
M10	48	28	41	

Always use these torques unless else is mentioned in the manual.

Tighten wheel bolts with the manufacturer's instructions.

Bolts with special attention are:

- Suspension
- Seats
- Seat belts

# Tools and chemicals used by Tripod



Sealant gun



Click clamp pliers



Rivet gun, used for Magna-lok rivets





Crimping tool, for electrical connections



Heat gun, for bending plastic fuel lines



Step drill, for drilling variable diameter holes



Brake bleeder





Cleaning solvent, type 1



Cleaning solvent, type 2

D



Contact spray glue, for the upholstery



Sikaflex 221 sealant, for sealing seams



Zink spray primer, for uncoated metal.  
First layer



1K epoxy primer  
Second layer



Satin black spray paint  
Third layer

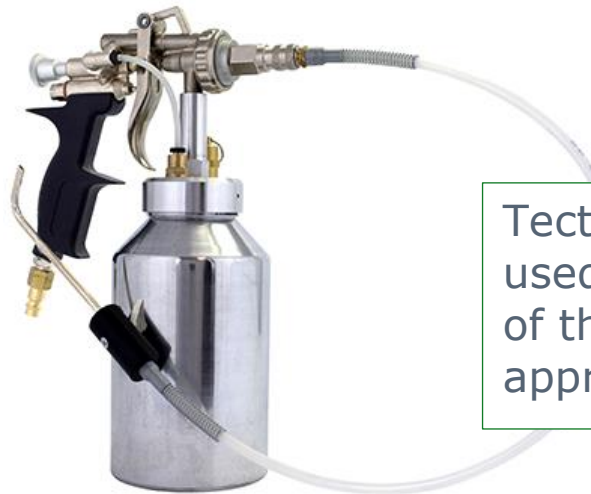

Tectyl Terotex HV450, used in all hollow parts of the body, with the appropriate spray gun



Tectyl Terotex 2000, used for protection of the underside of the chassis and lowered floor, with the appropriate spray gun





Tectyl ML, for parts where you can't use Tectyl Terotex HV450

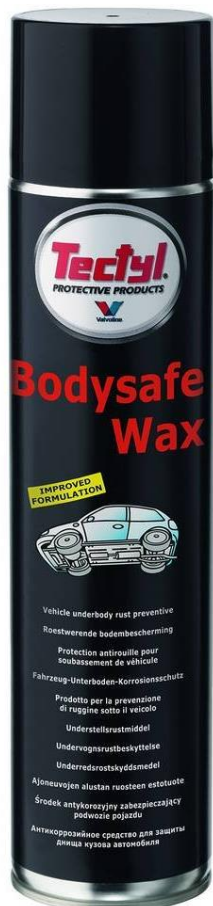

Tectyl Bodysafe, for parts where you can't use Tectyl Terotex 2000



## WHEELCHAIR ACCESSIBLE VEHICLES

If you want to receive product information (safety/data sheets) of the products mentioned in this chapter, please contact [support@tripodmobility.com](mailto:support@tripodmobility.com)

Disclaimer; descriptions are based on the information available during publication and are valid until further notice.  
We cannot guarantee the correctness and completeness of the information given and therefore do not accept liability.



[www.tripodmobility.com](http://www.tripodmobility.com) • Collseweg 10, 5674 TR Nuenen, the Netherlands  
T +31(0)40 283 6442 • F +31(0)40 283 6245 • E [info@tripodmobility.com](mailto:info@tripodmobility.com)