



WHEELCHAIR ACCESSIBLE VEHICLES

**RENAULT**  
Kangoo L1/L2



**MERCEDES-BENZ**  
Citan/T-class L1/L2



**NISSAN**  
Townstar L1/L2



**ELEGANT, SPACIOUS AND AVAILABLE FOR ANY ACTIVITY**

---

This model catches the eye with the reinterpretation of its characteristic profile. Comfort, modularity and driving pleasure.

# L1

Short version of L1.  
Car length 4,498m.

Tested and approved by:



## Measurements

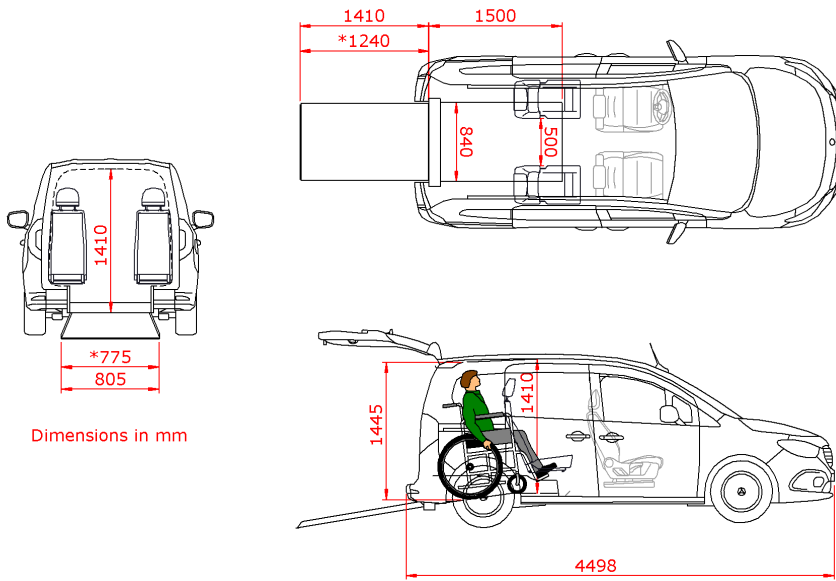

Dimensions in mm

\* Taxi ramp



## Seating options

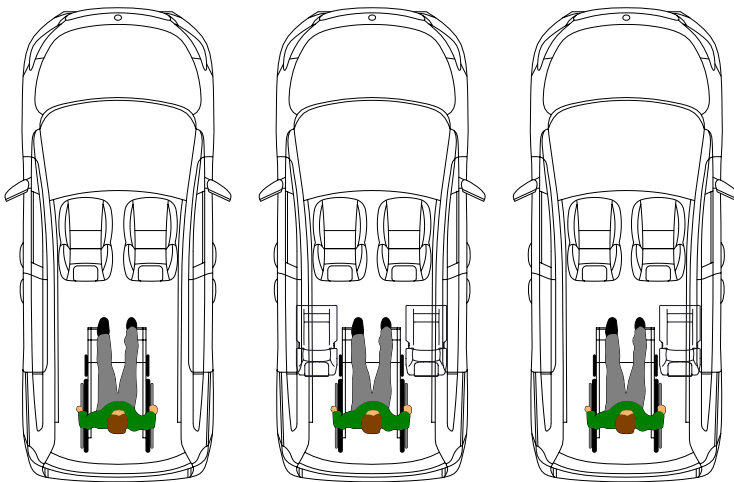

## Standard conversion

- Lowered floor from rear up between the 2<sup>nd</sup> row seats, fully covered with matching upholstery.
- 4-point wheelchair tie-down system with an adjustable 3-point safetybelt for the wheelchair passenger.
- New fuel tank and modified exhaust system to accommodate a deep and level lowered floor.
- Foldable taxi ramp which creates a flat loading floor.
- LED lights at ramp entrance for better visibility.
- The center part from the rear bumper will be replaced on the hatch, maintaining the original look.

## Options

- One or two (removable) Tripod seats on the 2<sup>nd</sup> row.
- Restore functionality of original parking sensors.

# L2

Long version or L2.  
Car length 4,910m.

Tested and approved by:



## Measurements

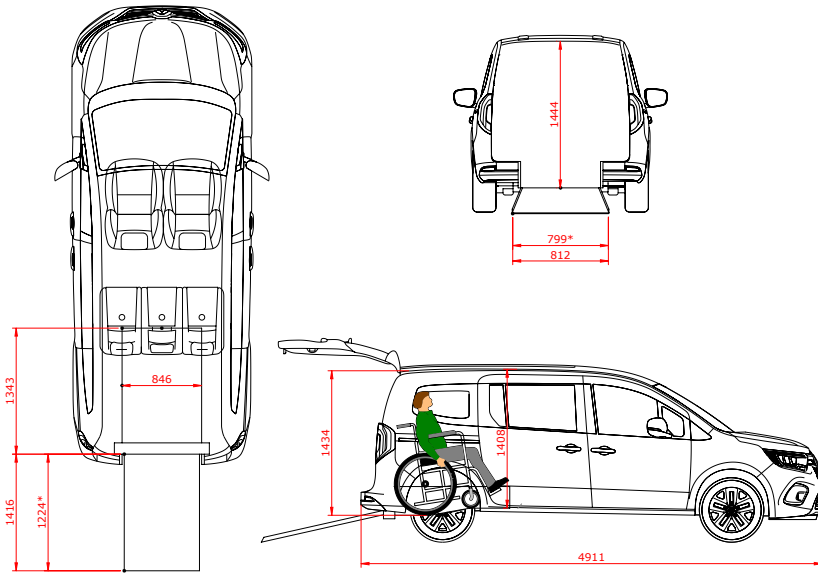

All dimensions in mm

\*Taxi ramp



## Seating options

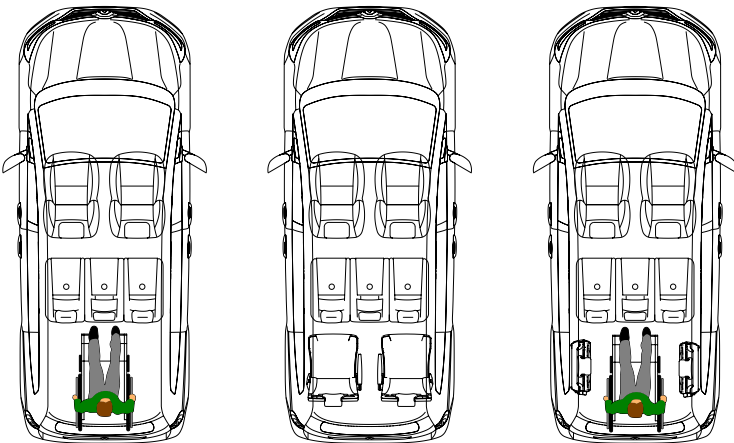

## Standard conversion

- Lowered floor from rear up between the 2<sup>nd</sup> row seats, fully covered with matching upholstery.
- 4-point wheelchair tie-down system with an adjustable 3-point safetybelt for the wheelchair passenger.
- New fuel tank and modified exhaust system to accommodate a deep and level lowered floor.
- Foldable taxi ramp which creates a flat loading floor.
- LED lights at ramp entrance for better visibility.
- The center part from the rear bumper will be replaced on the hatch, maintaining the original look.

## Options

- One or two TriflexAIR turn and fold seats on the 3<sup>rd</sup> row.
- Restore functionality of original parking sensors.

# Options

For each vehicle there are many optional extras available. Contact your dealer to discuss what options suit your needs.

## Safety

Tripod Mobility values your safety above all. All of our conversions have a full 2nd Stage European Type Approval.

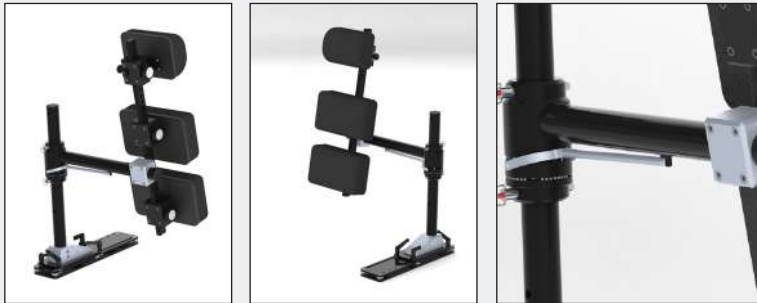

## BodyGuard

Designed to offer the same protection to the wheelchair user a good car seat:

- back and back support
- suitable for every car
- easily foldable
- safety tested

## TriflexAIR seats

- One of the slimmest and lightest swivel seats available.
- Extra comfort due to the high quality filling and breathable upholstery.
- Foldable and can be swiveled out of the way to make room for the wheelchair.
- M1 Approved & tested according to the highest safety standards .



## Taxi ramp

- Ramp that folds flat into the boot allowing flexible use of the boot space.
- For wheelchair users secured in an upright position.
- Easy access to luggage when folded down, holds up to 80kg.
- Clear rear view when folded down.

*Disclaimer; prices and descriptions are based on the information available during publication and are valid until further notice. We cannot guarantee the correctness and completeness of the information given and therefore do not accept liability.*